

Your competent partner

for components, truck and trailer kits and transport solutions

MASTHEAD

F. Hesterberg & Söhne GmbH & Co. KG

Heilenbecker Straße 50–60
58256 Ennepetal, Germany

Tel.: +49 2333 794-0
Fax: +49 2333 794-192
E-Mail: info@HESTAL.de

Registered office of the KG: Ennepetal, Hagen Regional Court, HRA 4180
VAT ID No.: DE126455410
Managing director: Dirk Miesen
General partner: HESTAL Umformung GmbH, Registered office Ennepetal, Hagen Regional Court, HRB 5702

Copyrights and legal notices

All rights reserved. Texts, figures and illustrations in this brochure are protected under copyright law and other protective legislation. The contents of this brochure may not be copied, disseminated, amended or made accessible to third parties, either in print form or in digital form. All copyrights and rights of use remain with the copyright holders. Reprinting – in whole or in part – only with the approval of F. Hesterberg & Söhne GmbH & Co. KG.



CONTENTS

THE COMPANY	4
THE STRATEGY	5
A QUOTATION	6
INTERNATIONAL SALES ORGANISATION	7
TERMS AND CONDITIONS OF SALE AND DELIVERY	9

WE ARE PLEASED TO WORK FOR YOU!

Traditional company and trendsetter, all in one

Hesterberg is one of the leading international manufacturers and suppliers of trailer superstructure and fastening systems with more than 230 years of tradition. The Hesterberg headquarters is in Ennepetal, Germany. This is where the ideas are developed and the products manufactured. Customers around the globe trust our products because of their reliability.

Security under the sign of the pigeon Our trademark since 1895

Our customers have associated quality products "Made in Germany" with the HESTAL brand name for many decades. They value the know-how and innovative product developments we have achieved over the years. Our roots go back to the 18th century. In 1780 the production of steel products for agricultural use was the cornerstone, the distribution of agriculture fasteners under the sign of the pigeon



in 1895 a milestone. In 1956 the trademark – HESTAL – was created, newly designed in 2012, overall representing the company Hesterberg and its products.

Customer in focus

The fulfilment of customer needs and requirements plays a central role in our company principles. Therefore, we are fully committed to meet your high expectations in our products continuously.



HESTERBERG AS MOBILITY AND SYSTEM PARTNER OF THE TRANSPORT INDUSTRY

As a partner of the transport and logistics industry and member of the BPW group, we support you with tailor-made solutions that help you fulfil your transport order as efficiently as possible. With durable products and comprehensive services, we as **mobility partners** help vehicle operators to make the whole loading and transport process safer and more efficient.

And as a **system partner** for vehicle manufacturers, we supply everything that optimises the vehicles and the production process. **With Hesterberg as a system partner**, you get everything from a single source. The products perfectly match and function together to offer the greatest possible benefit to the customer. During the development of our holistic systems and components, we pay particular attention to the demands and needs of the transport operators to enable them to fulfil their transport orders safely and efficiently.

And we have just one goal:

- To always offer you exactly the solution that pays off for you in the end.

In concrete terms that means for our partners:

- Individual consulting and development of components
- High-quality system solutions
- Customer-oriented supply concepts supporting your production process

To achieve this we offer uncompromising quality for high reliability and long service life, weight and time-saving concepts for lower operating and maintenance costs and personal after-sales service.

A complete portfolio based on the modular principle guarantees you the greatest possible flexibility: from individual components that represent the highest quality and reliability, through to complete, intelligent systems and user-friendly solutions.

The brands of the BPW Group:



A QUOTATION FROM JOHN RUSKIN

“There is hardly anything in the world that someone cannot make a little worse and sell a little cheaper, and the people who consider price alone are that person’s lawful prey.

It’s unwise to pay too much, but it’s worse to pay too little. When you pay too much, you lose a little money – that is all. When you pay too little, you sometimes lose everything, because the thing you bought was incapable of doing the thing it was bought to do.

The common law of business balance prohibits paying a little and getting a lot – it can’t be done. If you deal with the lowest bidder, it is well to add something for the risk you run, and if you do that you will have enough to pay for something better.”

 **[BE] Belgium**
 BPW BENELUX Sprl
 Parc industriel des Hauts-Sarts
 Premiere avenue 66
 4040 Herstal
 Tel. +32 4 264 04 61
 www.bpw-benelux.be

 **[CH] Switzerland**
 Fahrzeugbedarf AG
 Waldeggstr. 6
 CH-8812 Horgen
 Tel. +41 44 727 9797
 www.fbh.ch

 **[DK] Denmark**
 Transport-Teknik A/S
 Vranderupvej 2
 6000 Kolding
 Tel. +45 75 525200
 www.transport-technik.dk

 **[GB] England**
 BPW Limited
 CENTURION WAY
 Meridian Business Park
 Leicester LE19 1UZ
 Leicestershire
 +44 11 628 161 00
 www.bpw.co.uk

 **[EE] Estonia**
 GOKART AS
 Peterburi tee 111
 11415 Tallinn
 Tel. +372 623 0620
 www.gokart.ee

 **[FIN] Finland**
 BPW Kraatz Oy
 Ruukinmestarintie 9
 02330 Espoo
 Tel. +358 20 7936 700
 www.kraatz.fi

 **[FR] France**
 BPW France S.A.S.
 Paris Nord II
 195, Rue des Chardonnerets
 BP 59052 – Tremblay en France
 95947 Roissy C.D.G. Cédex
 Tel. +33 1 49381999
 www.bpwfrance.fr

 **[IT] Italy**
 BPW Italia s.r.l.
 Via Flavio Gioia, 5
 37135 Verona
 Tel. +39 045 508777
 www.bpwitalia.it

 **[LV] Latvia**
 XL Parts SIA.
 Maskavasielā 459
 1063 Riga
 Tel. +371 679 49377
 www.xlparts.lv

 **[LT] Lithuania**
 ROMASTA-Group, UAB
 Atlitiespl. 54
 52105 Kaunas
 Tel. +37037 373023
 www.romasta.lt

 **[NL] Netherlands**
 BPW BENELUX Sprl
 Kantorenpark "Het Kabinet"
 Le Havre 49
 5627 ST Eindhoven
 Tel. +31 40 2647870
 www.bpw-benelux.nl

 **[NO] Norway**
 BPW Hofstad A/S
 Ringnesveien 23
 0978 Oslo
 Tel. +47 22 101050
 www.bpw.no

 **[AT] Austria**
 Fahrzeugbedarf
 Kotz & Co. KG
 Industriestraße 7
 2353 Guntramsdorf
 Tel. +43 2236 414800
 www.fahrzeugbedarf.at

 **[PL] Poland**
 BPW Polska Sp.z o.o.
 Ul.Warszawska 205/219
 05-092 Lomianki
 Tel. +48 22 751 77 97
 www.bpw.pl

 **[SE] Sweden**
 FOMA
 Fordonsmateriel AB
 Lagegatan 15
 262 71 Ängelholm
 Tel. +46 431 458800
 www.fordonsmateriel.se

 **[ESP] Spain**
 BPW Trapaco, S.L.
 C/Miguel Servet, 12
 Pol. Ind. La Garena
 28806 Alcalá de Henares Madrid
 Tel. +34 91 802 36 00
 www.bpw.es

 **[TR] Turkey**
 BPW Otomotiv A.S.
 Sanayi ve Ticaret Anonim Sirketi
 Aydin caddesi-Aydin
 IS Merkezi Nr. 2/10
 34330 Levent-Istanbul
 Tel. +90 212 284 5450

 **[CZ] Czech Republic**
 BPW spol. s.r.o.
 Prumyslová 1842
 250 01, Brandys nad Labem
 Tel. +420 326 905805
 www.bpw.cz

 **[HU] Hungary**
 BPW-Drechsel & Kollár Kft.
 Táblás u. 28-30
 1097 Budapest
 Tel. +36 1 3477000
 www.bpwtrade.hu

 **[HU] Hungary**
 BPW-Hungária Kft.
 H-9700 Szombathely,
 Körmendi út 98.
 Tel. +36 94 517 200
 www.bpw-hungaria.hu

 **[UA] Ukraine**
 000 BPW-Ost
 Simi Sosninykh Str.3
 03148 Kiev, Ukraine
 Tel. +38 (044) 537-27-95
 www.bpw-ost.ru

 **[AU] Australia**

BPW Transpec Pty Limited
1-11 Cherry Lane
North Laverton
Melbourne 3026
Tel. +61 3 92672444
www.bpwtranspec.com.au

 **[CN] China**

BPW Meizhou Axle Co. Ltd.
Shanghai Office
Fortune Tower, Room 1001
Zhang Yang Road No. 655
Pudong
P.R. China – Shanghai 200120
Tel. +86 21 58304588
www.bpw.cn

 **[IN] India**

BPW Trailer Systems India
Private Limited
c/o German Center of
Industry and Trade
Building No.9, Tower 'B', Level 12
DLF Cyber City Phase III
Gurgaon 122002
Tel. +91 124 463 5863
www.bpwindia.com

 **[JP] Japan**

Nippon BPW Limited
Takuei Yokohama Nishiguchi
No 2., Bldg. 8F
Tsuruya-cho 3-35-8,
Kanagawa-ku
Yokohama, Kanagawa 221-0835
Tel. +81 45 317 9265

 **[KZ] Kazakhstan**

[KZ] Kazakhstan
000 BPW-Ost
Timiryazev Str. 42
050057 Almaty
Tel. +7 727 2459496
www.bpw-ost.ru

 **[NZ] New Zealand**

BPW Transport Efficiency Ltd.
10 Echelon Place
East Tamaki
Auckland
Tel. +64 9 2738084
www.tenz.co.nz

 **[RU] Russia**

000 BPW-Ost
Severniiy proezd
141426 Moscow, Chimki
Tel. +7 495 7716177
www.bpw-ost.ru

 **[SG] Singapore**

BPW Asia Pte Ltd
66 Joo Koon Circle,
Jurong
Singapore 629079
Tel. +65 68613111

 **[ZA] South Africa**

BPW Axles (Pty) Ltd.
Cnr. Kitty & Donald Streets
Chrisville 2091
Johannesburg
Tel. +27 11 680 1443
www.bpw.co.za

 **[TH] Thailand**

BPW Asia Pte Ltd
Representative Office Thailand
2/58 Seaboard Building, 3rd floor
Rayong Highway No. 3191 Road
Maptaphut, Rayong 21150
Tel. +66 38 692243

 **[BY] Belarus**

000 BPW-Ost
M. Bogdanovicha, 149 A
Office 24
220040 Minsk
Tel. +375 17 265 11 18
www.bpw-ost.ru

F. Hesterberg & Söhne GmbH & Co. KG – Heilenbeckerstr. 50–60 – 58256 Ennepetal

I. Applicable terms and conditions

The legal relations between F. Hesterberg & Söhne GmbH & Co. KG as the supplier (hereinafter referred to as "FHS") and the Customer are governed by these terms and conditions and any other additional agreements. Amendments and supplements to these terms and conditions must be made in writing, including waivers to the written form requirement. For the purpose of these terms and conditions, the written form requirement is equally met when carried out by electronic data transmission. Other general terms and conditions do not apply either, even if these conditions have not been expressly contradicted in any individual cases.

II. Orders

1. All delivery contracts (orders and acceptance) and calloff orders, along with any amendments and supplements to the same, must be made in writing. In the event that the written form requirement is not fulfilled, then the contract becomes valid at the latest when the order is executed by FHS (implied acceptance of order).
2. In the case that FHS fails to accept the order or the calloff order within three weeks after receipt then the customer has the right to cancel the order.
3. FHS reserves the right to make design changes to the product, as long as these changes do not affect its use and installation.

III. Payment

Unless agreed otherwise, the agreed price shall be paid by bank transfer within 14 days with 2% discount, or within 30 days net, after date of invoice. Generally prices are quoted EXW (as defined by Incoterms® 2010), including loading and packaging and excluding applicable VAT.

IV. Notice of Defects

The Customer is obliged to inspect the goods immediately after receipt, using the delivery documentation to check the type and quantity delivered, and to identify any obvious transport damages (including water entry). FHS must be notified in writing immediately of any shortages or damages. Other defects of the delivery must be reported immediately to FHS in writing as soon as they are identified in the normal course of business. In this case FHS waives its right of objection of late notification of defects.

V. Non-disclosure

1. The contractual parties are obliged to treat any commercial or technical information (in any form whatsoever), which is not public knowledge and has become known to them as a result of the business relationship as confidential.
2. In particular, drawings, sketches, models, samples, tools, test reports, measurement data, procedures, processes, programmes, software, parts lists, price and quantity agreements may not be disclosed to any unauthorised third parties or made available in any other way. The aforesaid remains the property of FHS and the Customer respectively. The copying of such information is permitted only within the framework of operational requirements and the copyright stipulations.
3. Sub-suppliers have to be bound accordingly.

VI. Dates of delivery

Agreed dates of delivery or deadlines are not binding, unless otherwise agreed in writing.

VII. Delay of delivery

1. Subject to the compliance with the legal prerequisites, FHS is obliged to compensate the Customer for damages caused by delay of delivery in the event of wilful intent or gross negligence. This does not apply to compensation for loss of profit and damages caused by disruption of operations, including possible contractual penalties to be paid by the Customer.
2. In the case of slight negligence, the damages payable are limited to additional freight costs and refitting costs.
3. In the event that the Customer has unsuccessfully given FHS a reasonable deadline to fulfil delivery obligations, then the compensation for damages is limited to the amount of additional expenditure incurred in making covering purchases.

VIII. Force majeure

Force majeure, strikes, unrest, governmental provisions (factory closures, factory restrictions, withdrawal or restriction of factory permits, etc.) and other unforeseeable, unavoidable and serious events release the contractual partners from their duty to perform their obligations for the period of the disruption and its effects. This also applies if these events occur at a time when the respective contractual party is in delay. The contractual parties are obliged to provide all required information within reason and without delay as far as possible to adapt their obligations to the changed circumstances in good faith.

IX. Quality and documentation

1. FHS must comply with all accepted standards of engineering, safety regulations and agreed technical data. Before making any changes to the product, e.g. in terms of the materials or manufacturing process, FHS shall inform the Customer in advance enabling the Customer to ascertain

whether the planned change will have any adverse effects. This duty of notification is waived if, after careful testing, FHS can assure the Customer that the possibility of adverse effects can be excluded.

With regard to initial sample inspections, volume no. 2 of the German Association of the Automotive Industry (VDA) report, "Ensuring Quality of Supply", in the latest version is applicable. Notwithstanding the foregoing, FHS must continuously inspect the quality of the goods supplied. The contractual parties will keep each other informed of possibilities for quality improvements.

2. In the event that FHS and the Customer have not specified the type and scope of these inspections and the testing equipment and methods to be used, the Customer shall, upon FHS's request, be prepared within the range of his expertise, experience and capabilities to discuss the testing procedure with FHS in order to determine the respectively required state of the testing technology. Moreover, the Customer must inform FHS of all relevant safety legislation.
3. With respect to the documentation and archiving of quality requirements (including special features), VDA volume no. 1 "Documentation and Archiving" in the latest version is applicable.
4. Insofar as the authorities that are responsible for vehicle safety, emissions standards etc. demand access to the Customer's production processes and test reports in order to ensure that certain standards are met, FHS undertakes to give all reasonable assistance upon the Customer's request.

X. Liability for defects

1. In the event of the delivery of defective goods, the Customer may demand the following, if the respective legal requirements and the requirements listed below have been met, and provided no other agreements have been made:
 - a) Before start of production (processing or fitting) the Customer shall, in the first instance, give FHS the opportunity to sort out, repair or replace the defective goods. In the event that FHS is unable to do so or if rectification or replacement is unacceptable for the Customer, then the Customer may terminate the contract without notice. In urgent cases the Customer may, with the agreement of FHS, rectify the defect himself or have it rectified by a third party. Any costs arising hereof have to be borne by FHS as agreed before. In the event that the same goods are repeatedly supplied in a defective condition, then, after issuing a written notification, the Customer is entitled to withdraw the contract with respect to the goods not yet supplied.
 - b) If the defect is discovered only after production, despite compliance with the obligation under the terms of Section IV (Notice of Defects), the Customer can claim in accordance with § 439 Sections 1, 3 and 4 BGB (German Civil Code) and as described in a) rectification or replacement and additional transport costs incurred for this rectification or replacement (excluding towing charges) and also dismantling and assembly costs (labour costs, material costs as far as these are agreed) or reduce the purchase price.
 - c) In the event of a culpable breach of obligation over and above the supply of defective goods (e.g. duty to notify, advise or examine), the Customer may demand compensation according to Section XI for consequential damages and also for consequential damages reimbursed by the Customer to his customer in accordance with the law. Consequential damages are damages which the Customer has suffered on other legally protected property as a result of the delivery of defective goods.
 - d) The Customer is entitled for further claims regarding expenses and damages arising from the delivery of defective goods only when this has been agreed beforehand. For any new agreements made, Section XVI, 1 must be observed.
2. The parts to be replaced shall be made available by the Customer to FHS immediately upon request and at FHS's expense or properly stored until inspection. In the event of costs being borne, FHS may request that the defective goods be destroyed.
3. Claims pertaining to liability for defects will expire 12 months after delivery. In the event of rectification of defects or replacement delivery the warranty period does not commence anew.
4. Claims are excluded insofar as the damages can be attributed to violation or nonobservance of the latest operating, maintenance and installation instructions and other technical documentation that is available also on the internet at www.FHS.de. Unsuitable or improper use, incorrect or careless handling and normal wear-and-tear, or changes to the delivered goods made by the Customer or a third party have the same effect.
5. In the event of defective goods delivered, the Customer's claims under the law of the Product Liability Act or of torts remain unaffected by this Section X. Guarantees of quality and durability must be expressly defined as such in detail and in writing.

XI. Liability

In the absence of any other liability provision within these terms and conditions, FHS is liable for compensation for damages incurred by the Customer either directly or indirectly as a result of legal reasons caused by FHS in the following cases only:

1. The obligation to pay compensation shall in principle apply only if FHS is liable for the damages caused as a result of wilful intent or gross negligence. This does not apply in cases of injury to life, body or health.
2. If the Customer is subject to claims with regard to third parties on the basis of strict liability, in accordance with mandatory law that is inalienable, FHS will indemnify the Customer against any such claims to the extent to which he himself would be directly liable.

Compensation payments between the Customer and FHS shall be settled by applying the princi-

ples of contributory negligence. This shall apply also in case of claims made directly against FHS.

3. The obligation to pay compensation is excluded in cases where the Customer has effectively restricted his liability in relation to his customer. In this respect the Customer shall endeavour to stipulate similar restrictions of liability to the benefit of FHS, insofar as legally permissible.

4. Claims by the Customer are excluded insofar as the damages can be attributed to violation or non-observance of the latest operating, maintenance and installation instructions and other technical documentation that is available also on the internet at www.FHS.de. Unsuitable or improper use, incorrect or negligent handling, normal wear-and-tear or faulty repair of goods have the same effect.

5. FHS shall be liable for measures taken by the Customer to prevent damages (e.g. recall action) insofar as FHS is legally obliged.

6. Should the Customer intend to claim against FHS in accordance with the aforementioned provisions, he shall immediately and comprehensively inform and consult FHS. He must give FHS the opportunity to investigate the damages incurred. The contractual parties shall agree any steps to be taken, in particular settlement negotiations. If FHS instigates a recall, the Customer undertakes to support FHS by all means possible.

7. Compensation for loss of profit and damages caused by disruption of operations, including possible contractual penalties to be paid by the Customer, is excluded.

XII. Intellectual Property Rights

1. FHS shall be liable for claims concerning violation of intellectual property rights resulting from contractual use of the supplied goods, if at least one of the family of intellectual property rights is published legally binding by the European Patent Office or in one of the following states: the Federal Republic of Germany, France or Great Britain. The Customer undertakes to use the supplied goods so as to avoid an infringement of any third party rights.

2. In the event of a liability in accordance with clause 1 above, FHS shall indemnify the Customer against any claims of third parties arising from the use of such intellectual property rights provided that FHS had the opportunity in accordance with clause 4 below to counteract such claims. Any further claims by the Customer are excluded.

3. FHS is not liable insofar as FHS has manufactured the supplied goods in accordance with drawings, models or similar other descriptions or information provided by the Customer. In this event the Customer indemnifies FHS against all claims from third parties.

4. The contractual parties agree to give each other the opportunity to counteract any claims resulting of any alleged contraventions.

5. The principles contained in Section XI, 1 – 3 and 7 regarding the limitation of liability shall apply accordingly.

XIII. Use of the Customer's means of production and confidential information provided by the Customer

Models, matrices, patterns, samples, tools and other means of production, as well as confidential information provided to FHS by the Customer or fully paid by him, may be used for deliveries to third parties only with the prior written consent of the Customer.

XIV. Retention of title

1. FHS retains ownership of all goods supplied until all claims resulting from the business relationship with the Customer have been settled in full; in this regard all individual deliveries shall be considered as components of one continuing delivery transaction. The retention of title shall act as security against any amounts outstanding.

2. If goods delivered are processed or transformed in the sense of § 950 Sect. 1 BGB (German Civil Code) or a new movable object is produced by means of processing or transformation of one or more materials, then FHS is deemed to be the manufacturer. In the event that moveable objects are joined together as defined by § 947 BGB (German Civil Code) or are mixed together or blended as defined by § 948 BGB (German Civil Code), and if one of these objects is to be considered the main object as defined by § 947 Sect. 2 BGB (German Civil Code), then the Customer assigns to FHS – insofar as the main object is not already the object(s) delivered by FHS – a co-ownership share in accordance with §§ 929 s. 1, 930 BGB (German Civil Code), in proportion to the value of the object(s) provided by FHS at the time of the joining, and grants FHS indirect possession in accordance with § 868 BGB (German Civil Code). Clause 1 above shall apply.

3. In the event that the Customer sells the delivered goods in accordance with the terms of the contract, he herewith assigns to FHS all his claims against his customer (inclusive of VAT) including any ancillary rights until all of FHS's claims have been settled in full, irrespective of whether the delivered goods have been sold with or without processing, transformation, joining, mixing or blending as defined in clause 2 above.

If there is a reasonable issue - especially in the event that the Customer does not meet his payment obligations - the Customer is obliged upon FHS's request to inform third parties of the assignment and to provide FHS with all the necessary information and documentation required for the assertion of his rights.

FHS shall release securities held insofar as their total value exceeds the claims being secured by more than 20%. FHS shall decide which securities are to be released.

XV. Transfer of risk, acceptance and default in acceptance

1. The transfer of risk is determined according to Incoterms® 2010 (or the current valid version thereof) agreed upon by FHS and the Customer.

2. The customer may not refuse acceptance on the grounds of a minor defect.

3. In the event that shipment is delayed or is not effected due to circumstances which are beyond FHS's responsibility, the risk is transferred to the Customer at the point in time at which he has been notified that the goods are ready for shipment or acceptance.

4. The obligation to sign an insurance coverage is determined according to Incoterms® 2010 (or the current valid version thereof) as agreed upon by FHS and the Customer.

5. Partial deliveries are permitted - provided this is reasonable for the Customer.

6. In the event that FHS withdraws from the contract due to reasons attributable to the Customer - especially due to default in acceptance - FHS can claim payment of damages in lieu of performance to a value of 25% of the agreed net invoice amount. The Customer is expressly permitted to provide evidence that no damages were incurred or that they were significantly lower than the flat rate of compensation.

FHS expressly reserves the right to make additional claims, taking into account the already paid flat rate of compensation as the minimum amount of the claim.

XVI. General Terms

1. In determining the level of damages to be paid by FHS in accordance with Sections VII, X, XI and XII, consideration shall be given in FHS's favour to FHS's economic circumstances, the nature, scope and duration of the business relationship, any possible contribution to the cause and/or fault of the Customer in accordance with § 254 BGB (German Civil Code) and any especially unfavourable assembly situation of the part supplied. In particular the compensation, costs and expenditure to be borne by FHS should be in reasonable proportion to the value of the part delivered.

2. In the event that one of the contractual parties ceases payment or if insolvency proceedings or non-judicial settlement proceedings against said party's assets are applied for, the other party has the right to withdraw from the yet unfulfilled part of the contract.

3. Should any provision of these terms and conditions or of further agreements be or become ineffective, the validity of the rest of the contract shall not be affected. The parties are obliged to replace the ineffective provision with one which is as close as possible to the original one.

4. Unless otherwise agreed, the law of the Federal Republic of Germany shall apply.

The application of the United Nations Convention on Contracts for the International Sale of Goods dated 11.4.1980 is excluded. In principle the contractual language is English.

5. The place of performance for delivery is determined according to Incoterms® 2010 (or the current valid version thereof) agreed upon by FHS and the Customer. The place of performance for payment is Ennepetal, Germany.

6. The court of jurisdiction is Hagen, Germany.

7. In accordance with the Data Protection Act it is hereby notified that FHS stores data relating to the Customer for use within the context of the cooperation.

As at 15. June 2013



Components

CONTENTS

CURTAINSIDER	15
Aluminium roof rail	16
Tarpaulin tensioner – TensionMaster II	17
Pillar system – VarioMaster 900, 901, 904, 905	19
Pillar system – VarioMaster 902, 903	23
Curtainsider pillar system 951	36
Espagnolette lock – LockMaster 709	42
Roof height adjustment system – LiftMaster 770N, 855N	46
REAR PORTAL DOOR	54
SmartMaster 500	55
SmartMaster II	57
Accessory and spare parts	61
FLATBED SUPERSTRUCTURE	68
Hinged pillars – SolidMaster 801, 802	69
Aluminium hinged pillars – SolidMaster 801A	97
Long-range-bolt fasteners	106
Flat-bolt fasteners	120
Tension-bolt fasteners	124
ALUMINIUM DROP-SIDE	127
Drop-side hinges 654N, 655N, 656N, 657	128
HESTAL Snap 25 profiles	131
HESTAL Snap 25 accessories	138

CONTENTS

BOX VAN		139
	Surface-mounted lock – LockMaster 890	142
	Built-in lock – LockMaster 891	146
	Surface-mounted lock – LockMaster NSB, NSE	154
	Box body hinge – HingeMaster 895	156
TIPPER		157
	Elbow handle fasteners	159
	Universal fastener	161
	Eccentric fasteners	162
	Tipper fasteners	165
SPARE PART SETS		169
CONFIGURATION TEMPLATES		173
CERTIFICATES		177
INDEX		188

OVERVIEW



LiftMaster
770N

TensionMaster II

LockMaster
709

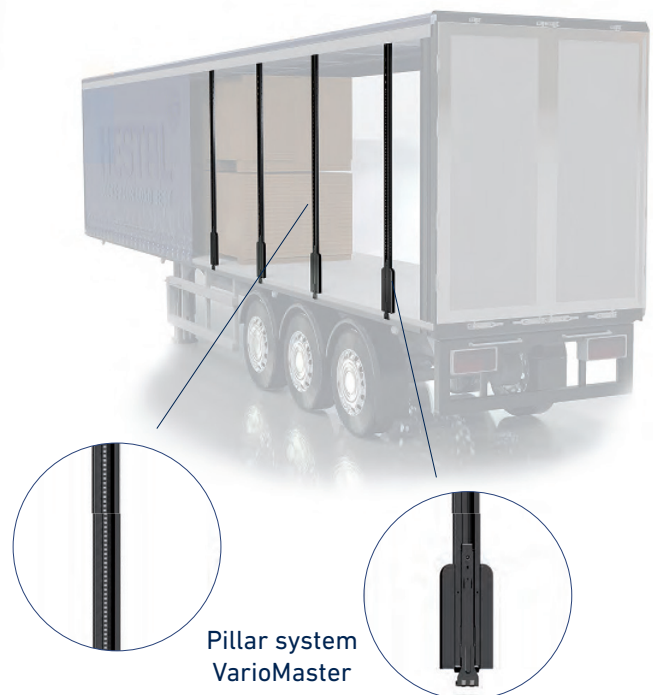

Pillar system
VarioMaster

- Aluminium roof rail
- Tarpaulin tensioner – TensionMaster II
- Pillar system – VarioMaster 900, 901, 904, 905
- Pillar system – VarioMaster 902, 903
- Curtainsider pillar system 951
- Espagnolette lock – LockMaster 709
- Roof height adjustment system – LiftMaster 770N, 855N

ALUMINIUM ROOF RAIL

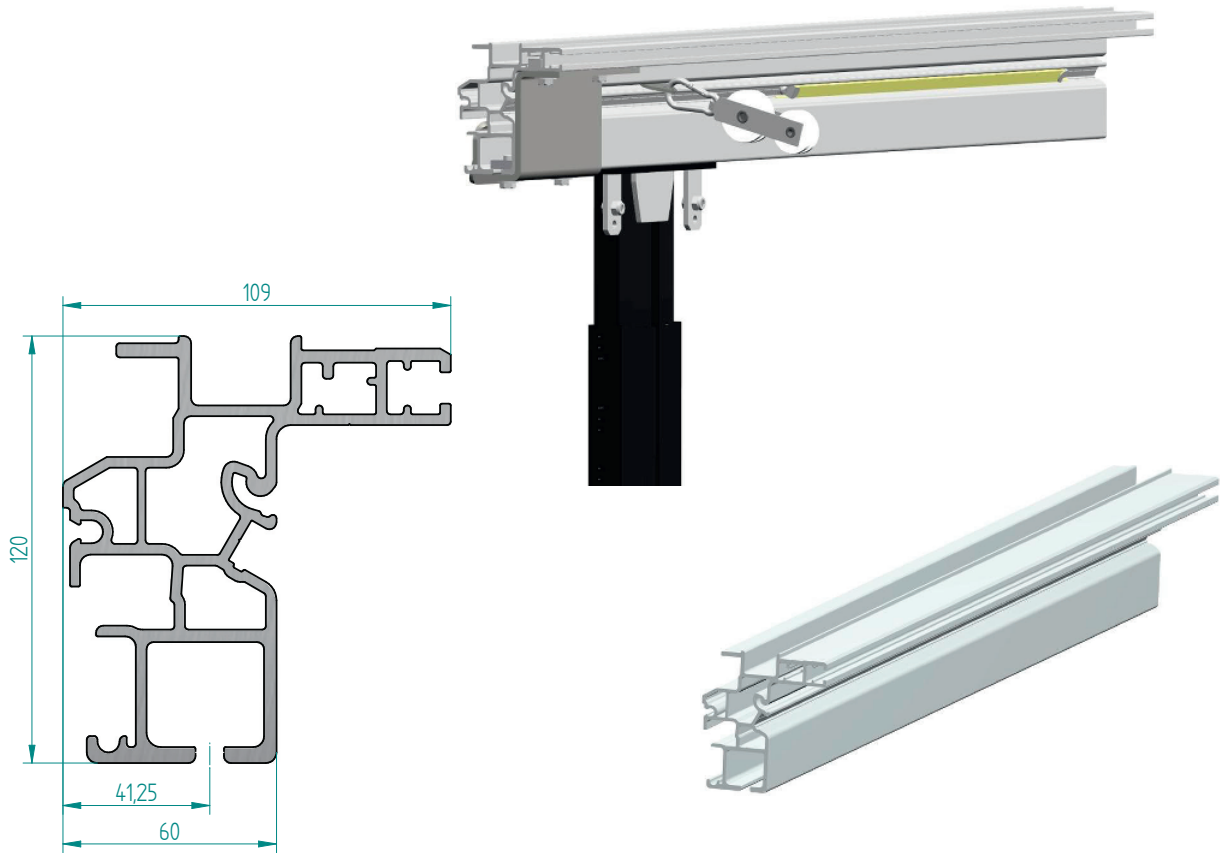

Advantages / benefits

- High degree of flexibility:
 - Allows free positioning of the strap lift system in longitudinal direction
 - Efficient and safe loading and unloading operations
 - Integration of LED light strips for cargo space lighting
 - Greater safety during loading and unloading
 - Integration of a miniature camera possible
 - For documentation purposes (quantity and security) or in combination with telematics box for optimisation of the loading capacity (planned)
- Designed for Versus and Sesam roof rails

Description	Weight	Length	Order no.
Roof rail	43.2 kg	7800 mm	6.660.001.10

*Subject to change | Date: July 2016

TARPAULIN TENSIONER – TENSIONMASTER II

The TensionMaster is a tarpaulin tensioner with simple operation and compact design.

Technology

- Quick and easy bolted mounting
- Available with slotted shaft or squared shaft
- Simple untightening of the tarpaulins (no additional holding of the retainer necessary)
- Only high-strength materials are used for production
- Optional: Customs cover cap

With slotted shaft

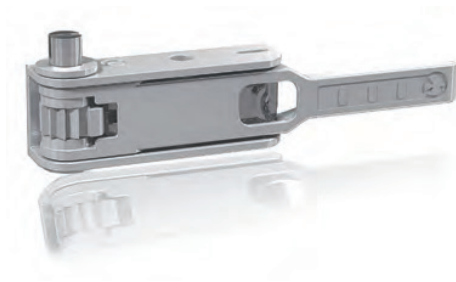

With squared shaft



Customs cover cap

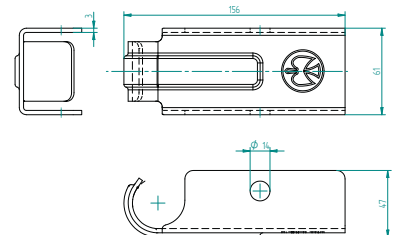
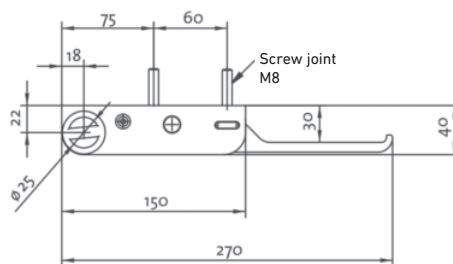
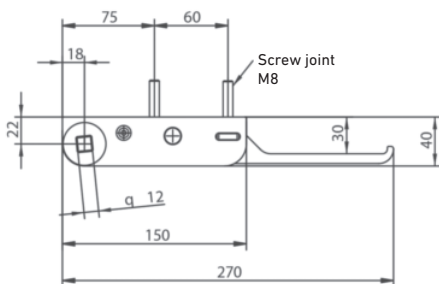

*Subject to change | Date: July 2016

TENSIONMASTER II – INDIVIDUAL COMPONENTS AND SPARE PART SETS

Description	Weight	Order No.
TensionMaster II with slotted shaft for tube Ø 35 mm Left side Right side	1.4 kg	6.141.204.98 6.141.203.98
TensionMaster II with squared shaft for tube Ø 27 mm Left side Right side	1.4 kg	6.141.202.98 6.141.201.98
Customs cover cap	0.066 kg	6.141.201.97
TM II main body with transport lock	1.4 kg	6.141.200.99
Installation set for squared shaft version Squared tensioner shaft M washer Rivet Untightening sticker German Untightening sticker English Installation instructions Operation sticker Ziplock bag		6.850.052.00
Installation set for squared shaft version Slotted shaft M washer Rivet Untightening sticker in German Untightening sticker in English Installation instructions Operation sticker Ziplock bag		6.850.053.00

*Subject to change | Date: July 2016

PILLAR SYSTEM – VARIOMASTER 900, 901, 904, 905

The HESTAL pillar system VarioMaster 900, 901, 904 and 905 is used as middle pillar for curtainsider vehicles.

Technology

- Robust, secure, and positive-fit connection to the outer frame by means of a pillar bearing
- The connection between CS pillar and outer frame is like a fixed bearing connection, creating a stable and high-strength CS pillar system
- Double safeguard mechanism
- Internal load height > 3 m possible
- Top trolleys and telescope can be used for a wide range of roof rails
- Pockets positionable in 5 mm intervals
- All components are KTL coated
- Pillar bearings for bolting and welding
- Adjustable fastening system allows driving with raised roof within the limits of the respective national road traffic regulations
- DEKRA tested

Versions

VarioMaster 900 "Code L" to DIN EN 12642

VarioMaster 901 "Code XL" to DIN EN 12642

VarioMaster 904 Double Decker "Code XL" to DIN EN 12642

VarioMaster 905 SlimMaster "Code XL" to DIN EN 12642

PILLAR SYSTEM – VARIOMASTER 900, 901, 904, 905

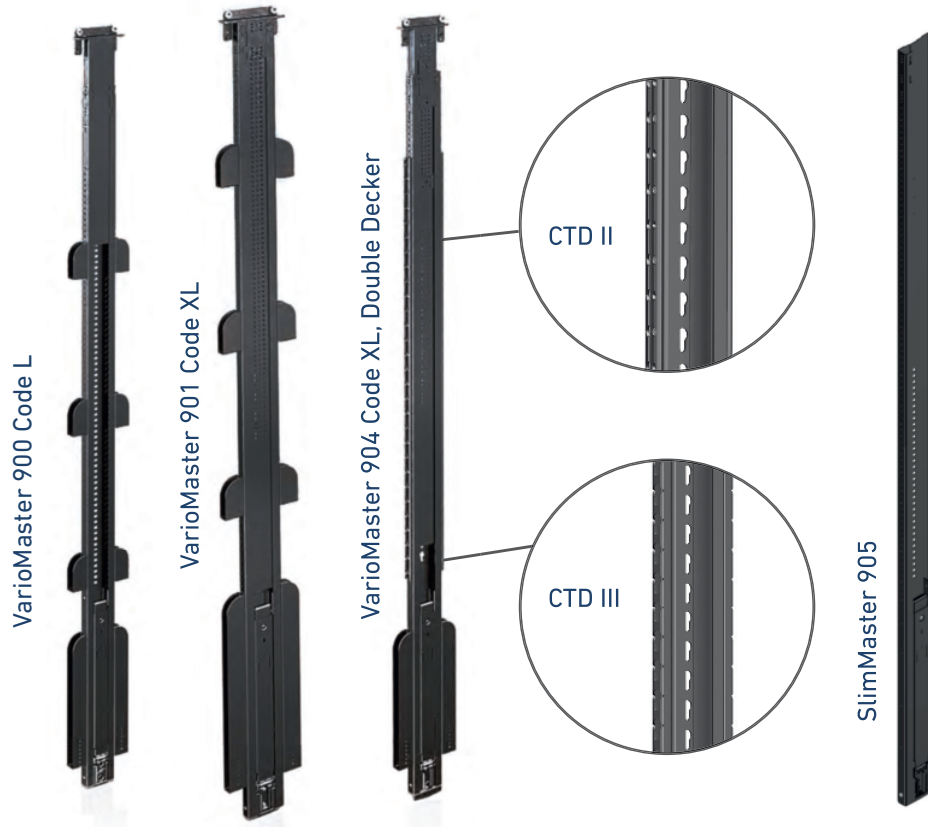

Description	Weight (kg)	Order No.
CS pillar 900 Code L with slat stowage, without pockets	21.6	6.800.197.00
CS pillar 900 Code L without slat stowage and pockets	19.5	6.800.175.00
CS pillar 901 Code XL with slat stowage, without pockets	23.1	6.800.198.00
CS pillar 901 Code XL without slat stowage and pockets	21	6.800.174.00
CS pillar long 901 Code XL with slat stowage, without pockets	24.7	6.800.212.00
CS pillar long 901 Code XL without slat stowage and pockets	22.6	6.800.211.00
CS pillar 904 Code XL (double decker) with slat stowage and CTD II perforated rails	27.3	6.800.215.00
CS pillar 904 Code XL (double decker) with slat stowage and CTD III perforated rails	27.5	6.800.216.00
CS pillar 904 Code XL (double decker) without slat stowage and perforated rail	21	6.800.206.00
SlimMaster 905	14.47	6.800.353.00

*Subject to change | Date: July 2016

PILLAR SYSTEM – VARIOMASTER 900, 901, 904, 905

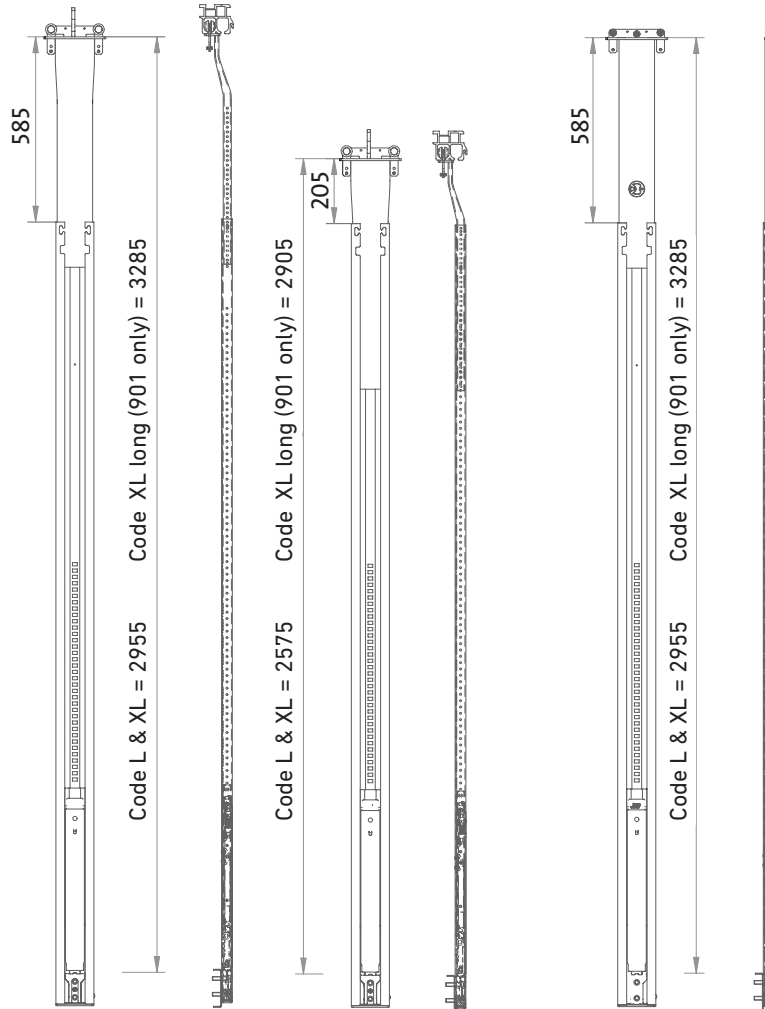

With angled top trolley
Representation of max. length

With angled top trolley
Representation of min. length

With straight top trolley
Representation of max. length

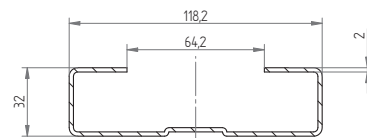
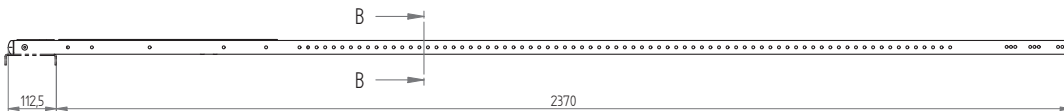
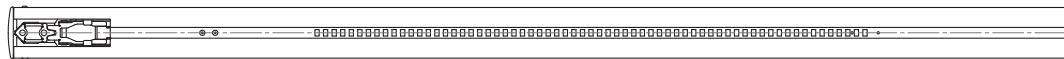

SlimMaster 905

*Subject to change | Date: July 2016

PILLAR SYSTEM – VARIOMASTER 900, 901, 904, 905

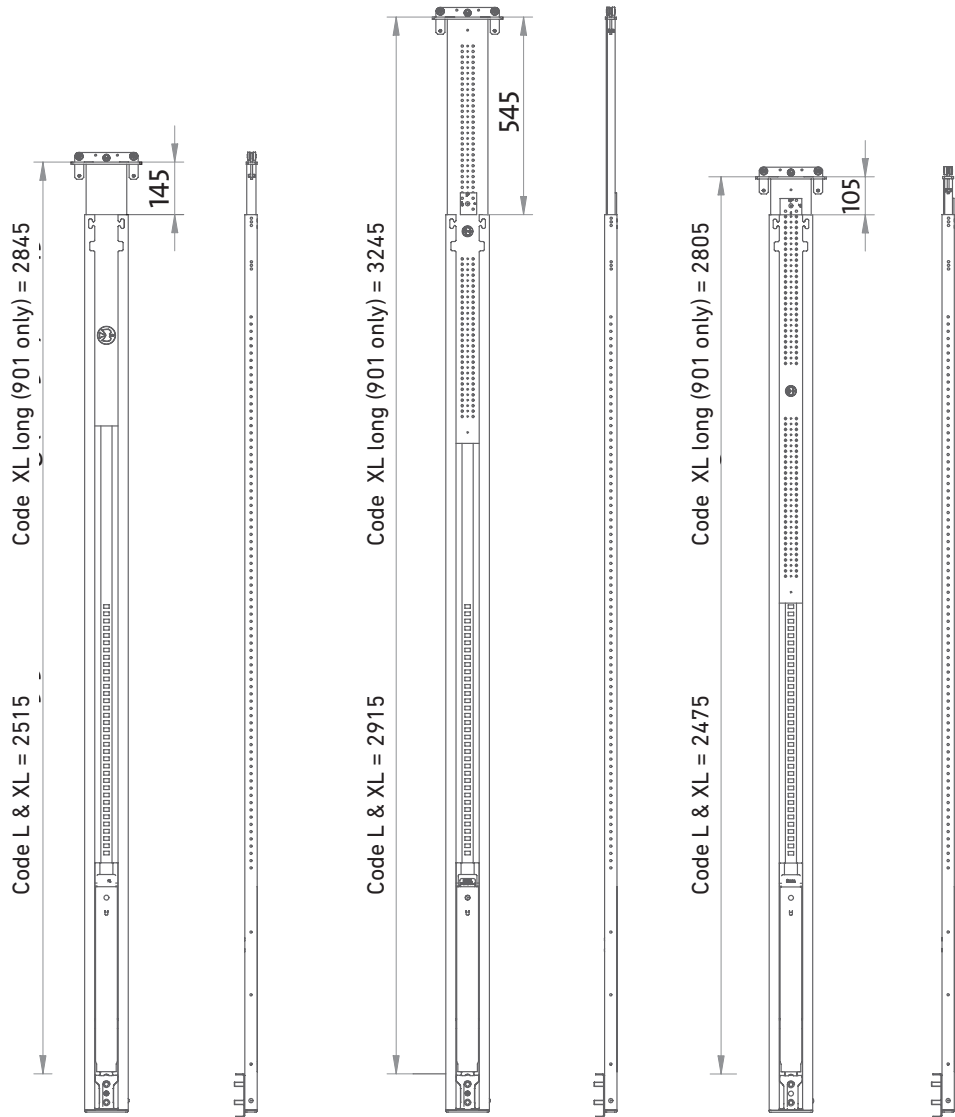

With straight top trolley
Representation of min. length

With telescope
Representation of max. length

With telescope
Representation of min. length

*Subject to change | Date: July 2016

PILLAR SYSTEM – VARIOMASTER 902, 903

The HESTAL pillar system VarioMaster 902 and 903 is used as middle pillars for curtainsider vehicles.

Technology

- Robust and variable connections to the outer frame
- The connection between CS pillar and outer frame is like a floating bearing connection
- Individual positioning of the VarioMaster on the outer frame (except with single pillar bearings)
- Internal load height 2500 mm to 3100 mm
- Top trolleys and telescope can be used for a wide range of roof rails
- Pockets positionable in 5 mm intervals
- All components are KTL coated
- Single pillar bearings for bolting and welding
- Boltable aluminium frame protection profile
- DEKRA tested

Versions

VarioMaster 902 "Code L" to DIN EN 12642

VarioMaster 903 "Code L" to DIN EN 12642

PILLAR SYSTEM – VARIOMASTER 902, 903

VarioMaster 902 Code L



VarioMaster 903 Code L



Description	Weight (kg)	Order No.
CS pillar 902 – short without pockets, without slat stowage	15.798	6.800.182.00
CS pillar 902 – long without pockets, without slat stowage	17.346	6.800.183.00
CS pillar 903 – short without pockets, without slat stowage	16.464	6.800.184.00
CS pillar 903 – long without pockets, without slat stowage	18.012	6.800.185.00

*Subject to change | Date: July 2016

PILLAR SYSTEM – VARIOMASTER 902, 903

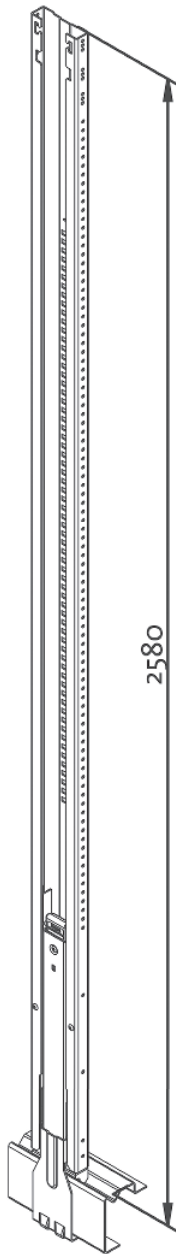

CS pillar 903
long

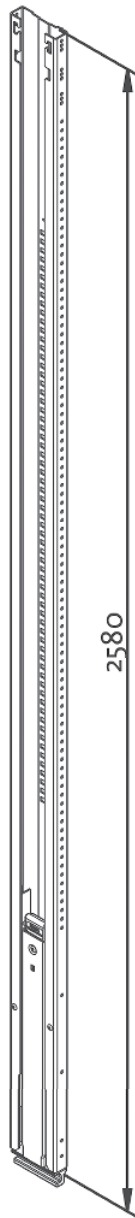

CS pillar 902
long

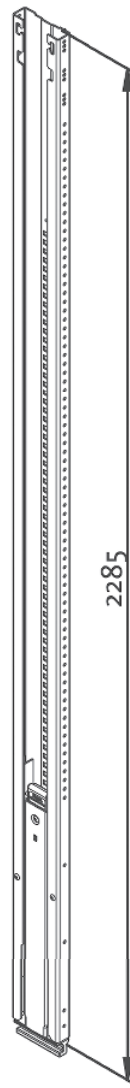

CS pillar 902
short

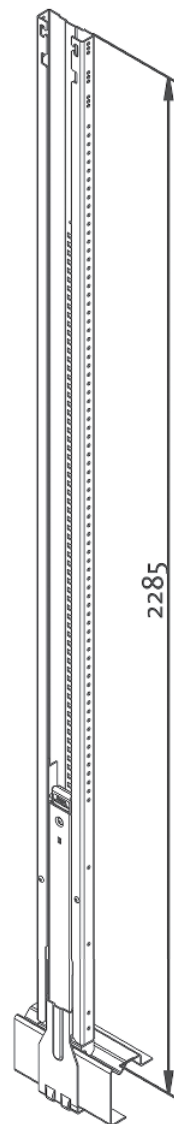

CS pillar 903
short

*Subject to change | Date: July 2016

VARIOMASTER 900, 901, 902, 903, 904, 905 – ACCESSORIES

Figure	Description	Weight	Order No.
	<p>Pocket</p>	<p>0.27 kg</p>	<p>6.800.174.10</p>
	<p>Slat storage 465 mm</p>	<p>1.05 kg</p>	<p>6.800.174.09</p>

*Subject to change | Date: July 2016

VARIOMASTER 900, 901, 902, 903, 904, 905 – ACCESSORIES

Figure	Description	Weight	Order No.
	<p>Slat storage 600 mm</p>	<p>1.369 kg</p>	<p>6.800.182.09</p>
	<p>Top trolley, straight</p>	<p>4.068 kg</p>	<p>6.090.154.00</p>

*Subject to change | Date: July 2016

VARIOMASTER 900, 901, 902, 903, 904, 905 – ACCESSORIES

Figure	Description	Weight	Order No.
	<p>Top trolley, straight</p>	<p>4.48 kg</p>	<p>6.090.157.00</p>
	<p>Top trolley, angled</p>	<p>4.23 kg</p>	<p>6.090.153.00</p>

*Subject to change | Date: July 2016

VARIOMASTER 900, 901, 902, 903, 904, 905 – ACCESSORIES

Figure	Description	Weight	Order no.
	<p>Pillar bearing 910.1 M12 raw M12 KTL</p>	0.6 kg	<p>6.090.151.98 6.090.151.99</p>
	<p>Pillar bearing 910.1 M14 raw M14 KTL</p>	0.6 kg	<p>6.90.220.98 6.090.220.99</p>
	<p>Plug-in fastening system 910.2 for telescope pillars</p>	0.33 kg	6.090.158.00

*Subject to change | Date: July 2016

VARIOMASTER 900, 901, 902, 903, 904, 905 – ACCESSORIES

Figure	Description	Weight	Order no.
	<p>Reinforcing profile for XL pillars in combination with a trolley</p>	<p>3.5 kg</p>	<p>6.800.174.12</p>
	<p>Collision protection profile</p>	<p>2.9 kg</p>	<p>6.090.116.68</p>
	<p>Single pivot shoe</p>	<p>0.610 kg</p>	<p>6.090.121.00</p>

*Subject to change | Date: July 2016

VARIOMASTER 900, 901, 902, 903, 904, 905 – ACCESSORIES

Figure	Description	Weight	Order no.
	<p>Drop-side stop without pocket Right Left</p>	<p>0.7 kg</p>	<p>6.800.258.01 6.800.258.02</p>
	<p>Drop-side stop with pocket Right Left</p>	<p>0.9 kg</p>	<p>6.800.258.50 6.800.258.51</p>

*Subject to change | Date: July 2016

VARIOMASTER 900, 901, 902, 903, 904, 905 – ACCESSORIES

Figure	Description	Weight	Order no.
	<p>Telescope 912.5 complete with accessories for XL pillars, for square roof rails</p>	<p>12.5 kg</p>	<p>6.090.177.00</p>
	<p>Telescope 912.3 complete with accessories</p>	<p>9.5 kg</p>	<p>6.090.156.00</p>



*Subject to change | Date: July 2016

VARIOMASTER 900, 901, 902, 903, 904, 905 – ACCESSORIES

Figure	Description	Weight	Order no.
	<p>Double Decker CTD II</p>	<p>1.3 kg</p>	<p>6.800.215.01</p>
	<p>Double Decker CTD III</p>	<p>2.198 kg</p>	<p>6.800.216.01</p>

*Subject to change | Date: July 2016

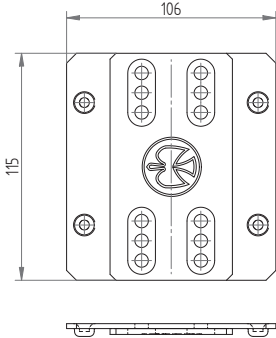
VARIOMASTER 900, 901, 902, 903, 904, 905 – ACCESSORIES

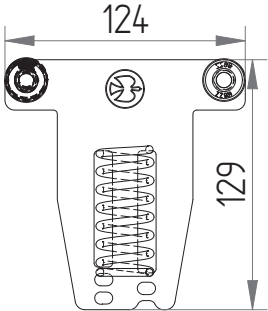
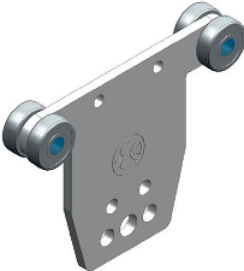
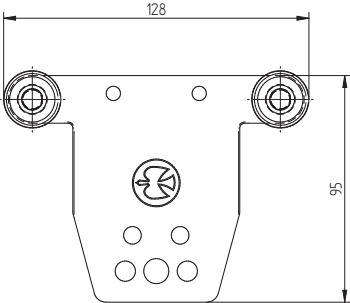
Figure	Description	Weight	Order no.
	<p style="text-align: center;">Telescope element stop</p> 	0.36 kg	6.090.248.00
	<p style="text-align: center;">Rollers with spring damping</p> 	0.43 kg	6.090.226.00
	<p style="text-align: center;">Rollers</p> 	0.34 kg	6.090.284.51

*Subject to change | Date: July 2016

CURTAINSIDER PILLAR SYSTEM 951

Field of application

The HESTAL CS 951 pillar system is used as middle pillar for commercial vehicles with laterally sliding tarpaulins.

Technology

- Through its design, the Curtainsider pillar HESTAL 951 satisfies the applicable Code XL requirements. DEKRA certificate available on request.
- This is achieved through a pillar thickness of 35 mm in conjunction with high-strength material and a newly developed latch mechanism. The Curtainsider pillar is secured with a double locking mechanism and is safeguarded against opening unintentionally through the proven toggle-lever principle in the latch element.
- The internal rocker allows the pillar to be easily brought back into its original position after opening. For the fixed connection to the frame profile, the proven SolidMaster pivot bearing is used.
- Additional attachment elements, such as slat stowage and pockets can be attached at the height and in the quantity desired as normal.
- The connection to the vehicle roof, as a telescoping or fixed unit, requires only one element. This can be adjusted to the different application area with very little effort.

Advantages / benefits

- Sturdy basic design of a CS pillar with outstanding price/performance ratio
- High product reliability
- Certified to DEKRA and in accordance with DIN EN 12642-XL
- High degree of flexibility
- Roof connection can be adapted (in 10 mm increments)
- Slat stowage in 4 different positions
- Pocket position adjustable (in 5 mm increments)
- Pillar bearing identical with SolidMaster

Versions

- Version with top trolley or telescope (see Accessories)
- KTL coating

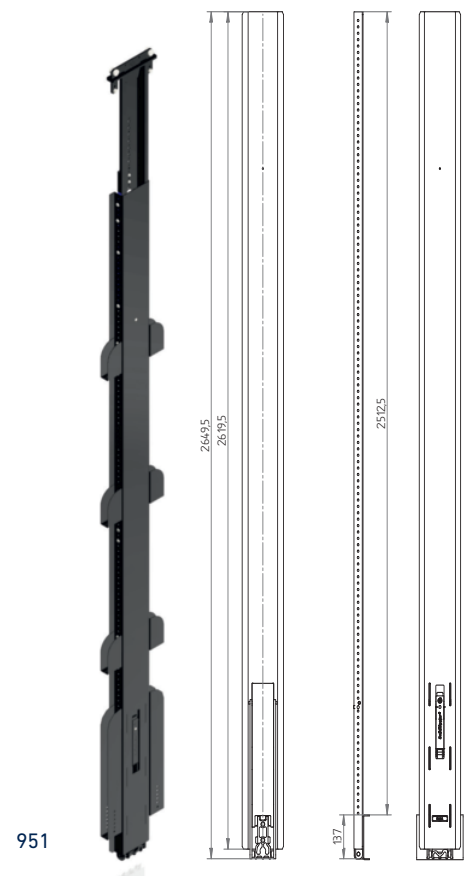

*Subject to change | Date: July 2016

CURTAINSIDER PILLAR SYSTEM 951 – ACCESSORIES

Figure	Description	Weight	Order no.
	<p>Slat storage Short – 465 mm Long – 602 mm</p>	<p>1.046 kg 1.356 kg</p>	<p>6.800.174.09 6.800.182.09</p>
	<p>Pocket</p>	<p>0.27 kg</p>	<p>6.800.174.10</p>
	<p>Stop plate</p>	<p>0.239 kg</p>	<p>6.800.409.13</p>

*Subject to change | Date: July 2016

CURTAINSIDER PILLAR SYSTEM 951 – ACCESSORIES

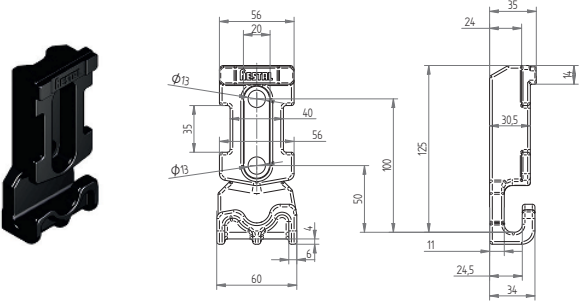
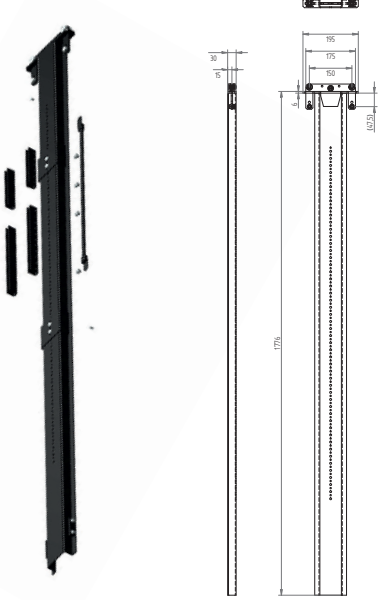
Figure	Description	Weight	Order no.
	<p>Tensioning cable (400 – 450 mm stroke)</p>	<p>0.074 kg</p>	<p>6.090.155.25</p>
	<p>Pillar bearing M12 M14</p>	<p>0.884 kg 0.735 kg</p>	<p>6.090.201.99 6.090.227.99</p>
	<p>Telescope set Code XL Straight Offset</p>	<p>6.775 kg</p>	<p>6.090.237.00 6.090.245.00</p>

*Subject to change | Date: July 2016

CURTAINSIDER PILLAR SYSTEM 951 – ACCESSORIES

Figure	Description	Weight	Order no.
	<p>Top trolley set, Code XL Straight Offset</p>	<p>6.775 kg</p>	<p>6.090.238.00 6.090.246.00</p>
	<p>Telescope set Code XL – angled Top trolley set Code XL – angled</p>	<p>9.879 kg</p>	<p>6.090.240.00 6.090.244.00</p>

*Subject to change | Date: July 2016

CURTAINSIDER PILLAR SYSTEM 951 – ACCESSORIES

Figure	Description	Weight	Order no.
	<p>Top trolley, complete Straight Offset</p>	<p>2.519 kg</p>	<p>6.090.239.00 6.090.247.00</p>
<p>6.090.237.55 6.090.245.55</p>	<p>Roof connection, complete Straight Offset</p>	<p>6.775 kg</p>	<p>6.090.237.55 6.090.245.55</p>

*Subject to change | Date: July 2016

CURTAINSIDER PILLAR SYSTEM 951 – ACCESSORIES

Figure	Description	Weight	Order no.
	<p>Roof connection, angled</p>	<p>9.879 kg</p>	<p>6.090.240.55</p>

*Subject to change | Date: July 2016

ESPAGNOLETTE LOCK – LOCKMASTER 709.18

Can be used with curtainsider, flatbed, folding wall and box body superstructures. The LockMaster 709.18 impresses with its high-strength and sturdy design and its easy handling.

Technology

- Self-locking safety button
- The self-latching detent is additionally held in the closed position by a separate pawl
- For 25 mm and 30 mm door thickness
- One version for left and right doors
- Collision protector
- Lockable with padlock + cylinder lock
- Good draw-in properties for locking the doors
- Customs version possible (German Customs Criminal Investigation Office certificate)
- Optimised anti-rack properties
- Retrofitting of door holding facility (door fix) possible
- Hot-dip galvanised version
- Pivotal spacing 22 + 1 mm
- For M8 (8.8) mounting bolts
- Powder-coated version

Versions

Hot-dip galvanised to FHS-TL 9.22

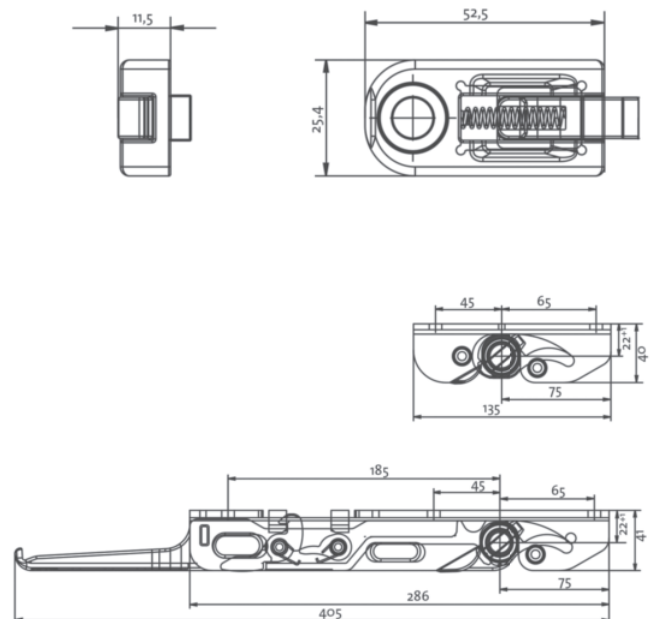
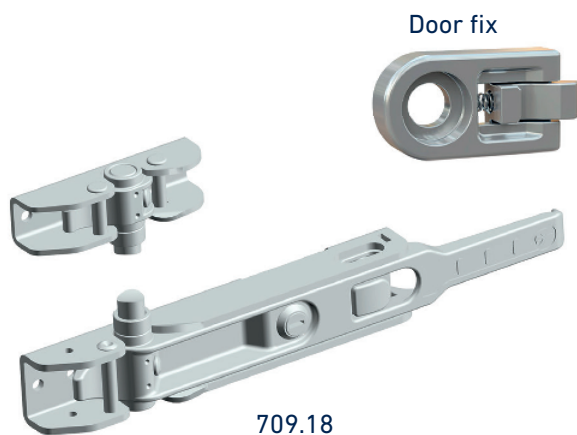

*Subject to change | Date: July 2016

LOCKMASTER 709.18 – INDIVIDUAL COMPONENTS

Figure	Description	Weight	Order no.
	Door fix	0.082 kg	6.141.719.00
	Clamping lever standard Ø 16 mm	1.451 kg	6.141.123.97
	Clamping lever standard Ø 18 mm	1.451 kg	6.141.220.98

*Subject to change | Date: July 2016

LOCKMASTER 709.18 – INDIVIDUAL COMPONENTS

Figure	Description	Weight	Order no.
	<p>Clamping lever with lock Ø 18 mm</p>	<p>1.468 kg</p>	<p>6.141.220.99</p>
	<p>Lower counter holder, standard</p>	<p>1.14 kg</p>	<p>6.141.705.50/98</p>
	<p>Lower counter holder, short</p>	<p>1.09 kg</p>	<p>6.141.695.98</p>

*Subject to change | Date: July 2016

LOCKMASTER 709.18 – INDIVIDUAL COMPONENTS

Figure	Description	Weight	Order no.
	Clamping cam Ø 16 mm	0.211 kg	6.141.672.99
	Clamping cam Ø 18 mm standard	0.163 kg	6.141.673.99
	Leading clamping cam Ø 18 mm	0.175 kg	6.141.121.27
	Upper counter holder, standard	0.398 kg	6.141.687.99
	Upper counter holder, short	0.39 kg	6.141.695.99

*Subject to change | Date: July 2016

ROOF HEIGHT ADJUSTMENT SYSTEM – LIFTMASTER 770N

- The LiftMaster is an easy to operate manual roof height adjustment system
- Optimum use of the whole available cargo volume
- The cargo volume of trailers increases by 3.3–8.2 m³, depending on the roof rail installed

Field of application

- For raising the roof of curtainsider vehicles
- Max. roof stroke 300 mm, 400 mm, 500 mm
- Max. roof weight 1000 kg (including all roof components to be lifted)

Technology

- The LiftMasters are preinstalled in a U-shaped housing (60x30 mm)
- The LiftMasters are equipped with a lifting mechanism and three different actuating devices
- The LiftMasters have an arresting device that allows the vehicle to be driven with the roof raised by up to 120 mm

Supplement

Available for the HESTAL VarioMaster 900 Series with a matching telescope solutions

Versions

KTL black coated to FHS-TL 9.13



770N

*Subject to change | Date: July 2016

ROOF HEIGHT ADJUSTMENT SYSTEM – LIFTMASTER 770N



Length mm	Weight (kg)	Order no.
Stroke 300 mm – Lift arrest up to 120 mm	18.0 kg	6.810.179.00
Stroke 400 mm – Lift arrest up to 120 mm	18.0 kg	6.810.168.00
Stroke 500 mm – Lift arrest up to 120 mm	20.0 kg	6.810.169.00

*Subject to change | Date: July 2016

LIFTMASTER 770N – ACCESSORIES

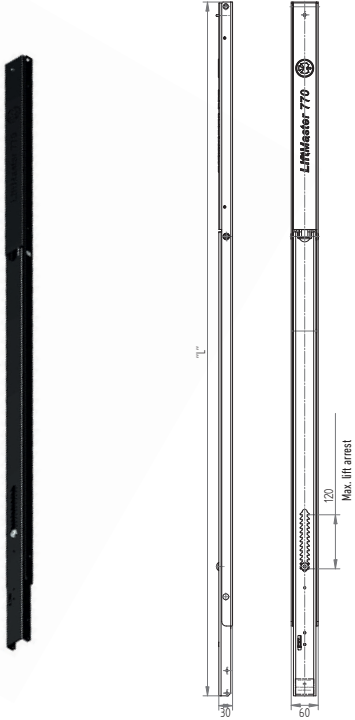
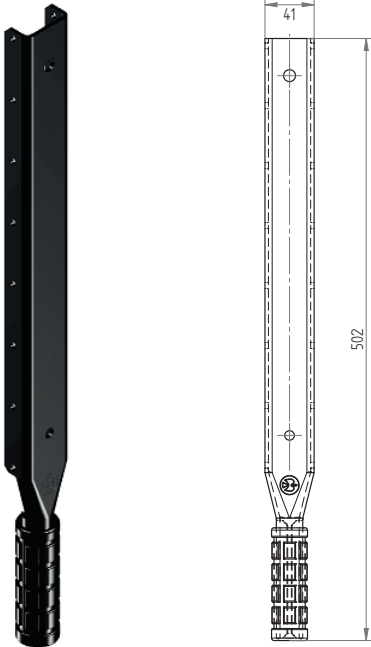
Figure	Description	Order no.
	<p>BG lift mechanism</p> <p>Lengths: 300 mm 400 mm 500 mm</p>	<p>6.810.179.60 6.810.168.60 6.810.169.60</p>
	<p>Hand lever</p>	<p>6.810.060.53</p>

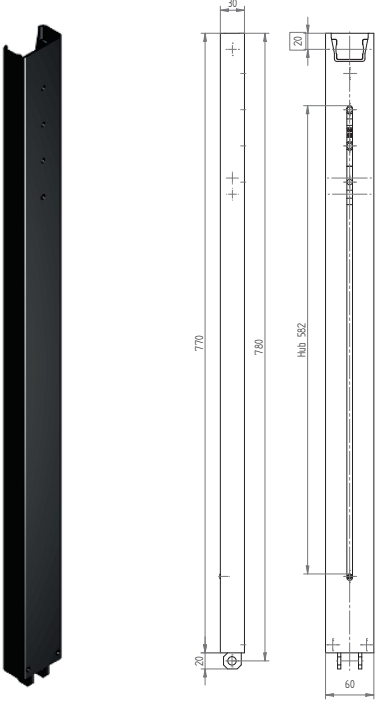

*Subject to change | Date: July 2016

LIFTMASTER 770N – ACCESSORIES

Figure	Description	Order no.
	<p>Drag bearing</p>	<p>6.810.078.99</p>
	<p>Guiding channel</p>	<p>6.810.078.59</p>

*Subject to change | Date: July 2016

LIFTMASTER 770N – SPARE PART SETS

Figure	Description	Order no.
	<p>Spare part set lift mechanism 770N 300 mm Spare part set lift mechanism 770N 400 mm Spare part set lift mechanism 770N 500 mm</p> <p>Blocking spring Bearing bush Lock washer 12 Cup spring A28F Washer 15 Pressure spring Ø 1.6 x 20 x 73.5 Thrust rod Cylinder pin Ø 4h8 x 26 Conversion Instructions Shipping tube HESTAL "original spare parts" plastic bag Weiconlock AN 306-30 20 ml</p>	<p>6.850.042.03 6.850.042.04 6.850.042.05</p>
	<p>Spare parts set for LiftMaster hand lever with release mechanism</p> <p>BG4 hand lever profile Bearing ring with twist lock Bearing bolt</p>	<p>6.850.057.00</p>
	<p>Lift limit for hand lever</p> <p>Stop belt Fillister head screw M5 x 55 Self-locking nut M5 with press-fit washer</p>	<p>6.850.058.00</p>

*Subject to change | Date: July 2016

ROOF HEIGHT ADJUSTMENT SYSTEM – LIFTMASTER 855N

- The LiftMaster 855N is an automatic roof height adjustment system
- Raising the vehicle roof allows the whole available cargo volume to be used
- The cargo volume of trailers increases by 3.3–8.2 m³, depending on the roof rail installed

Fields of application

For raising the roof of curtainsider vehicles in the truck and trailer segment.
Roofs up to a total weight of 1600 kg (incl. all roof parts to be lifted) can be raised by up to 580 mm.

Technology

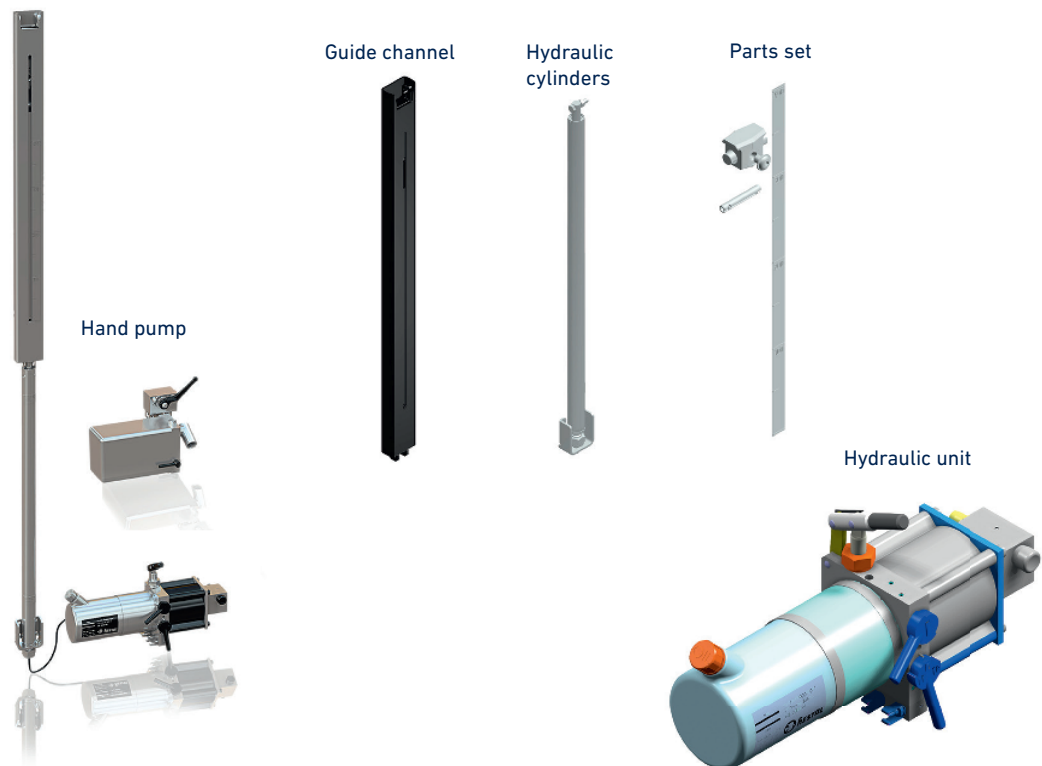

- The control unit allows the whole roof or a single roof side to be raised
- In an emergency or when no compressed air is available (manual mode), the LiftMaster can be operated with a hand pump
- The system includes a dead man’s handle for safety reasons
- The lift mechanism can be welded into the corner frame profiles



Description	Order no.
LiftMaster 855N – Hydraulic unit with cylinders and guiding channel, 4 cylinders	6.810.090.00
LiftMaster 855N – Hydraulic hand pump	6.810.091.00
LiftMaster 855N – Hydraulic unit with cylinders and guiding channel, 2 cylinders	6.810.092.00



*Subject to change | Date: July 2016

LIFTMASTER 855N – ACCESSORIES

Figure	Description	Order no.
	<p>Hydraulic unit</p>	<p>6.810.088.03</p>
	<p>Hydraulic hand pump</p>	<p>6.810.088.20</p>
	<p>Hydraulic cylinder</p>	<p>6.810.088.53</p>
	<p>Guiding channel</p>	<p>6.810.078.59</p>

*Subject to change | Date: July 2016

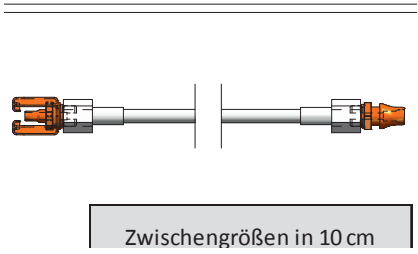
LIFTMASTER 855N – ACCESSORIES

Figure	Description	Order no.
	<p>Parts set</p>	<p>6.810.085.81</p>
 <p>Zwischengrößen in 10 cm</p>	<p>Hydraulic hose Ø 4 mm Various lengths available Lengths on demand</p>	<p>6.810.088.04</p>
	<p>Hydraulic hose Ø 8 mm with protective sheath Various lengths available Lengths on demand</p>	<p>6.810.200.00</p>

*Subject to change | Date: July 2016

OVERVIEW



- **SmartMaster 500S and 500A**
- **SmartMaster II**
- **Accessories and spare parts**

*Subject to change | Date: July 2016

REAR PORTAL DOORS

SMARTMASTER 500S AND 500A

For curtainsider and dry freight vehicles

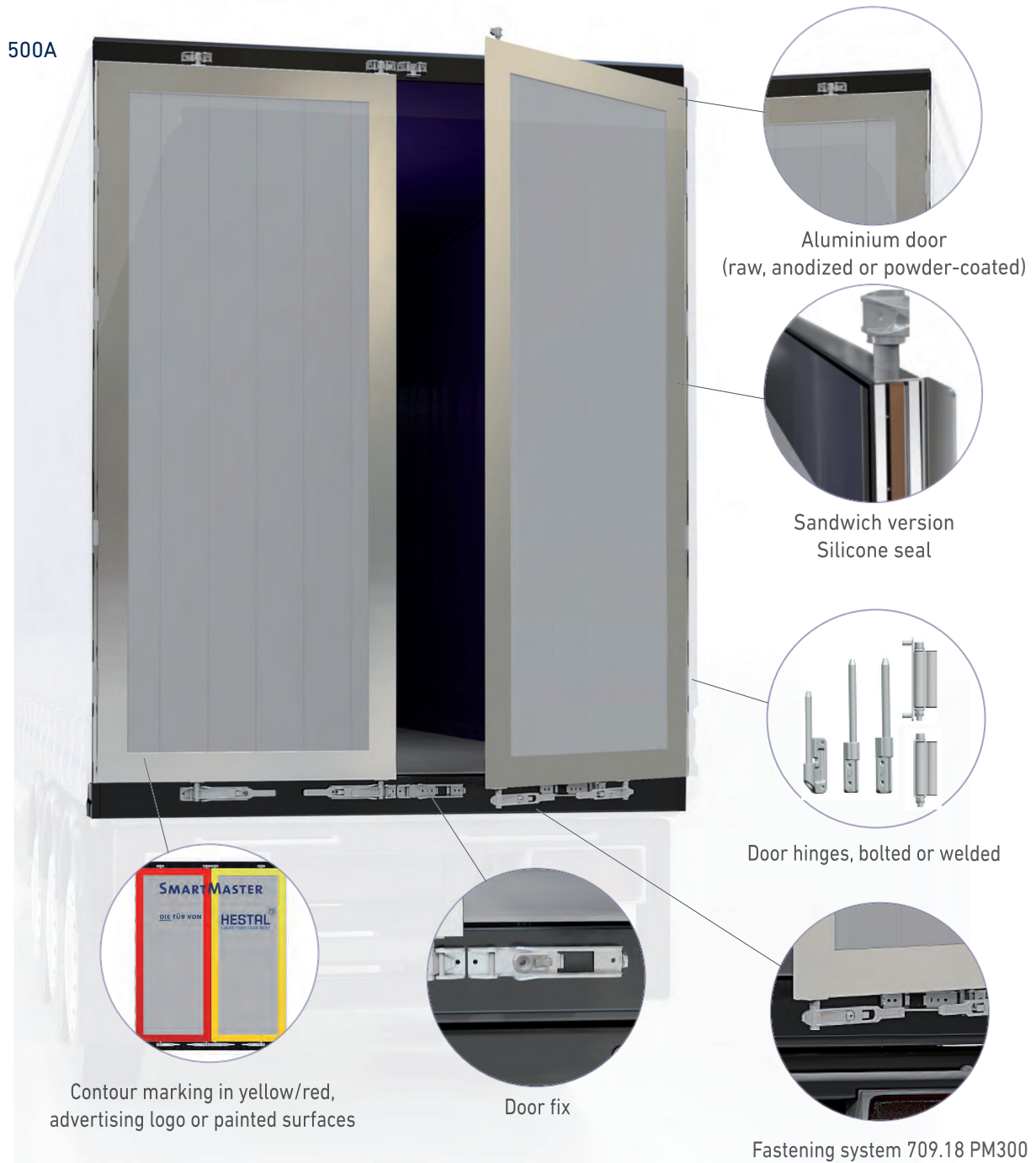

*Subject to change | Date: July 2016

REAR PORTAL DOORS

SMARTMASTER 500S AND 500A

For curtainsider and dry freight vehicles

Technology

- In solid aluminium (500A or sandwich version 500S)
- Certified to DIN EN 12642 XL
- Anodised aluminium frame
- Sandwich panel either painted in white or with blue, red or yellow plastic foil as 5-year foil
- Door always with the latest HESTAL door fastener
- Closed silicone door seal
- Other special versions possible

Versions

- Rear portal closes in front of the portal

Logos

Sandwich panel delivered with logo as:

- Normal foil logo in 2 quality grades
- Reflective foil logos (certified)
- Digital foil logo with UV protection laminate

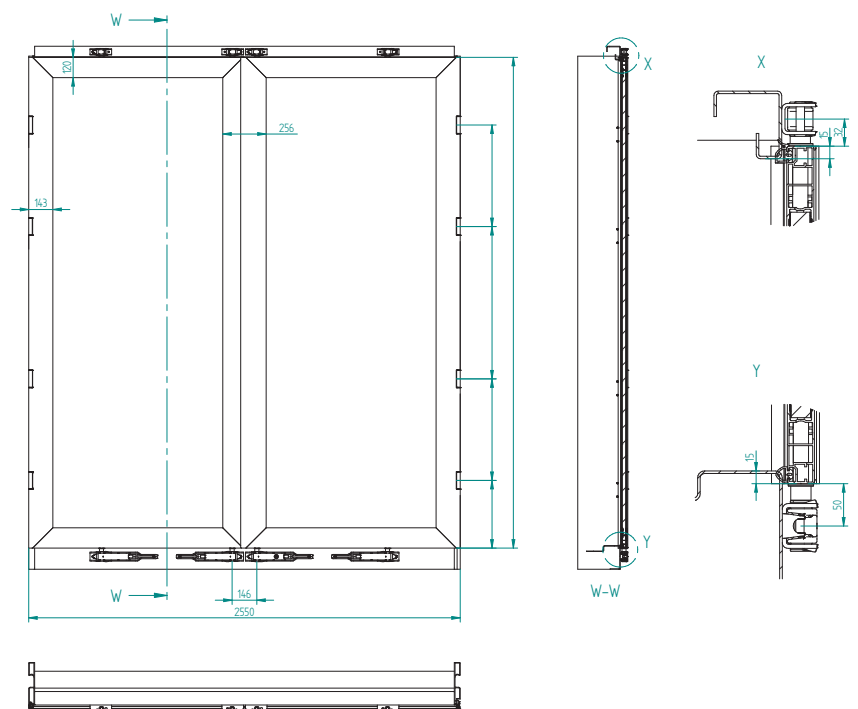

*Subject to change | Date: July 2016

SMARTMASTER II

For curtainsider and dry freight vehicles



- **SmartMaster II**
- **SmartMaster II Kit**

*Subject to change | Date: July 2016

REAR PORTAL DOORS

SMARTMASTER II, ASSEMBLED

Technology

- Rear door is made out of aluminium hollow-chamber profiles which are clipped together
- Proven „Clip“-technology (HESTAL Snap 25)
- Robust profile design while keeping the weight to a minimum
- Certification according to DIN EN 12642, Code XL appendix A, up to 29 tonnes payload
- Door width 2550mm
- Door thickness 25mm
- No visible rivet connections
- Anodized surface
- Weight depends on the design max. 130kg
- HESTAL-hinges and HESTAL-fasteners
- Double hinge for opening angles up to 270°

Benefits

- Up to 20% weight reduction compared with SmartMaster I
- TÜV-certified structural rigidity, Code XL, up to 29 tonnes payload
- Anodized surface
- Proven HESTAL-hinges and fasteners
- One of the door fasteners can be locked
- In case of repair: easy replacement of the aluminium profiles
- Fatigue strength verification (tested with 5 Mio. load changes)
- Silicone seal

Design

- Rear portal closes in front of the portal

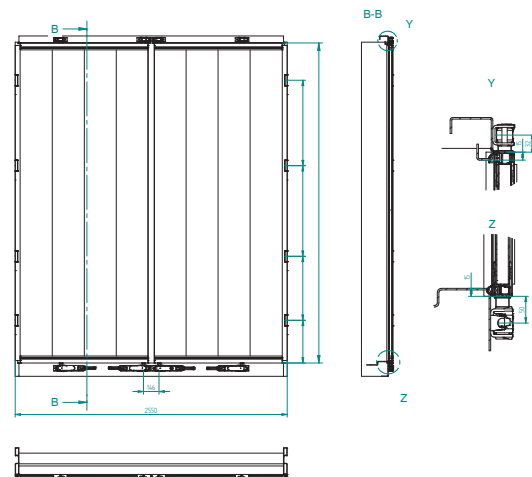

*Subject to change | Date: July 2016

SMARTMASTER II KIT

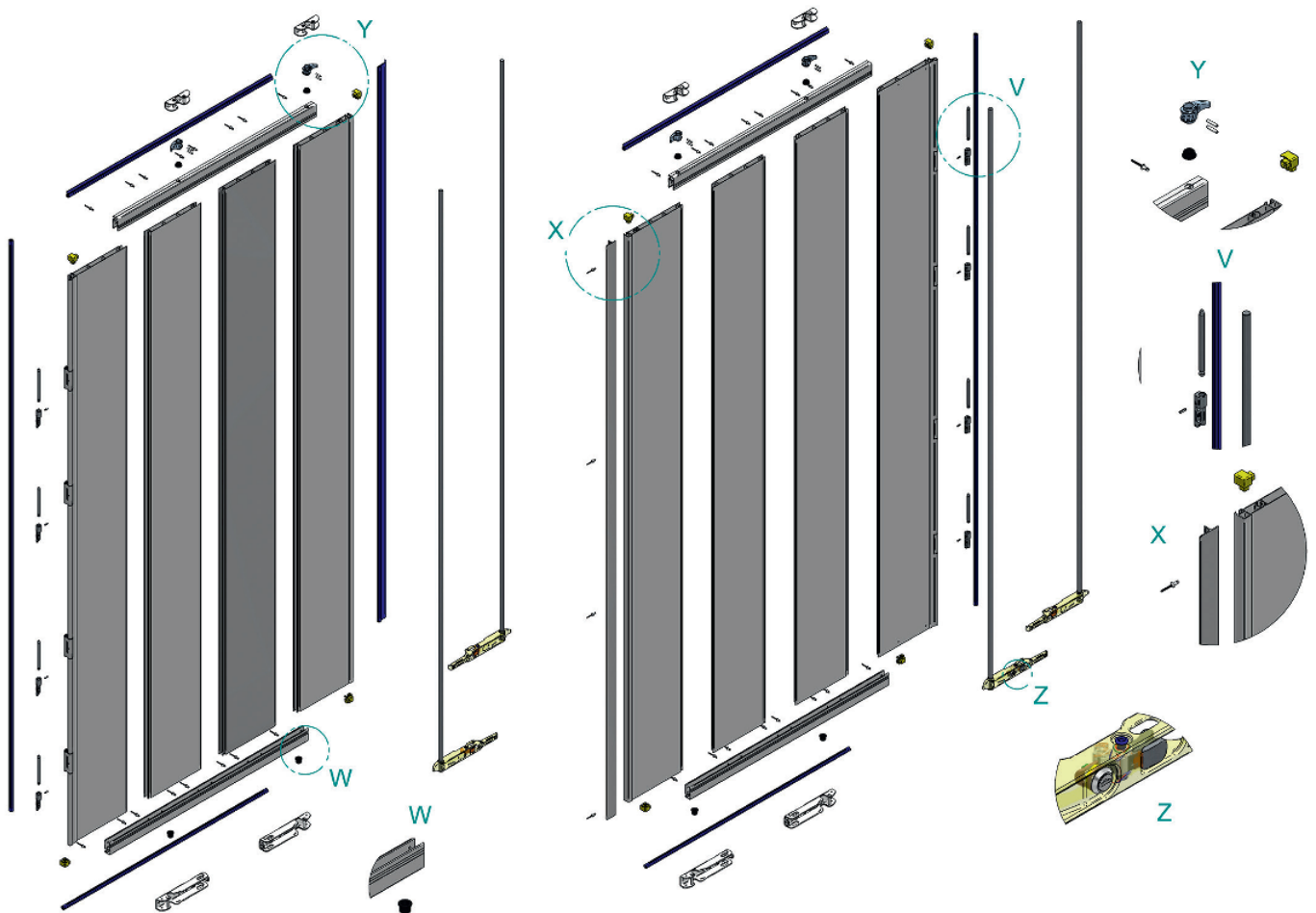

Length	Width	Thickness	Weight	Order no.
2400 mm	2550 mm	25 mm	123 kg	6.500.107.00
2800 mm	2550 mm	25 mm	140 kg	6.500.108.00
3100 mm	2550 mm	25 mm	148 kg	6.500.109.00

*Subject to change | Date: July 2016

SMARTMASTER II KIT

Technology

- Rear door is made out of aluminium hollow-chamber profiles which are clipped together
- Proven „Clip“-technology (Hestal Snap 25)
- Robust profile design while keeping the weight to a minimum
- Certified according to DIN EN 12642, Code XL appendix A, up to 29 tonnes payload
- Door width: 2550mm | Door height from 2000 up to 3300mm | Door thickness: 25mm
- No visible rivet connections and anodized surface
- Weight depends on the design max. 130kg
- HESTAL-hinges and HESTAL-fasteners
- Double hinge for opening angles up to 270°

Benefits

- Up to 20% weight reduction compared with SmartMaster
- The silicone seals can be easily installed even though they've got painted
- Available from stock
- Pre-assembled hinge profile
- Door heights: 2,40m (3 hinges); 2,80m (4 hinges); 3,10m (4 hinges)
- individually adaptable with simple tools
- Freight-paid delivery within a radius of 150 kilometers around Ennepetal and within 24 hours
- Valid XL-certification if the assembly is done according to manufacturer's specifications
- Can be assembled within 30 minutes (2 people needed)
- Fixed hinge positions
- Surface anodized
- Pre-assembled espagnolette

Suggested garage equipment

- Hand drill, drill templates are provided
- Rivet tool: minimum 15 KN set force such as manual rivet tool MD 6M (GTO), battery blind rivet tool TIOS ER15 (GTO), pneumatic blind rivet tool MS 60 (GTO), G4 (Avdel) – additional data on request
- Hammer
- Saw for aluminium processing
- Tooling for seal assembly (can be purchased from Hesterberg)
- 5m measuring tape
- Workbench

*Subject to change | Date: July 2016

SMARTMASTER 500S, 500A AND SM II – ACCESSORIES AND SPARE PARTS

Figure	Description	Order no.
	Door fix	6.141.719.00
	Clamping lever without lock	6.141.230.40
	Clamping lever with lock Locking mechanism 001 Locking mechanism 002 Locking mechanism 003 Locking mechanism 004 Locking mechanism 005 Locking mechanism 006 Locking mechanism 007 Locking mechanism 008 Locking mechanism 009 Locking mechanism 010	6.141.230.51 6.141.230.52 6.141.230.53 6.141.230.54 6.141.230.55 6.141.230.56 6.141.230.57 6.141.230.58 6.141.230.59 6.141.230.60
	Upper clamping cam	6.141.121.27

*Subject to change | Date: July 2016

SMARTMASTER 500S, 500A AND SM II – ACCESSORIES AND SPARE PARTS

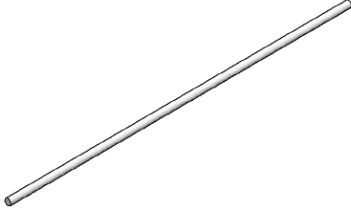
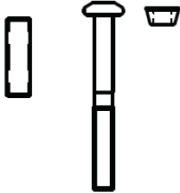
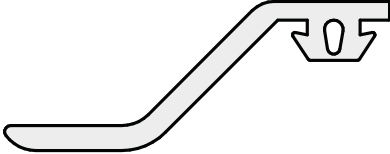
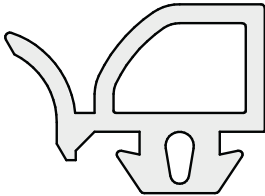
Figure	Description	Order no.
	<p>Espagnolette Ø 18 mm, 3500 mm</p>	<p>6.500.070.01</p>
	<p>Locking ring bolt set, for fastening clamping lever and clamping cam to the espagnolette</p>	<p>6.141.680.00</p>
	<p>Inner seal (centre seal)</p>	<p>6.500.001.38</p>
	<p>Upper seal</p>	<p>6.500.001.39</p>

*Subject to change | Date: July 2016

SMARTMASTER 500S, 500A AND SM II – ACCESSORIES AND SPARE PARTS

Figure	Description	Order no.
	Outer and lower seal	6.500.001.26
	Bush with collar (h = 12 mm) Bush with collar (h = 18 mm) Bush with collar (h = 20 mm)	6.500.060.01 6.500.060.02 6.500.060.03
	Bush with collar (h = 12 mm)	6.500.060.16
	Bush without collar (h = 12 mm) Bush without collar (h = 30 mm)	6.500.050.02 6.500.050.03

*Subject to change | Date: July 2016

SMARTMASTER 500S, 500A AND SM II – ACCESSORIES AND SPARE PARTS

Figure	Description	Order no.
	<p>Collared bush (h = 20 mm, d = 12 mm) Collared bush (h = 24 mm, d = 14 mm)</p>	<p>6.500.001.28 6.500.001.29</p>
	<p>Hinge bearing, bolted version</p>	<p>6.500.008.00</p>
	<p>Hinge bearing, welded version</p>	<p>6.500.007.00</p>
	<p>Fillister head screw Nut Washer for hinge bearing 6.500.008.00 and 6.500.007.00</p>	<p>6.500.008.21 6.500.008.22 6.500.008.23</p>

*Subject to change | Date: July 2016

SMARTMASTER 500S, 500A AND SM II – ACCESSORIES AND SPARE PARTS

Figure	Description	Order no.
	Hinge bearing, bolted version, side Left Right	6.500.009.50 6.500.009.51
	Hinge bearing, bolted version, upright bolt (short) Bolted version right Bolted version left Welded version right Welded version left	6.500.011.60 6.500.011.61 6.500.011.62 6.500.011.63
	Hinge bearing, bolted version, upright bolt (long) Bolted version right Bolted version left Welded version right Welded version left	6.500.011.64 6.500.011.65 6.500.011.66 6.500.011.67
	Hinge bolt, short Hinge bolt, long	6.500.011.23 6.500.011.24

*Subject to change | Date: July 2016

SMARTMASTER 500S, 500A AND SM II – ACCESSORIES AND SPARE PARTS

Figure	Description	Order no.
	Hinge bracket Bolted version right Bolted version left Welded version right Welded version left	6.500.011.21 6.500.011.22 6.500.011.25 6.500.011.26
	Lower counter-holder Lower counter-holder with customs hook	6.141.234.50 6.141.234.52
	Upper counter-holder Upper counter-holder with customs hook	6.141.234.55 6.141.234.57
	Scuff protection rail	6.500.080.00

*Subject to change | Date: July 2016

SMARTMASTER 500S, 500A AND SM II – ACCESSORIES AND SPARE PARTS

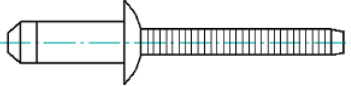
Figure	Description	Order no.
	Rivet for scuff protection rail	6.090.122.07

*Subject to change | Date: July 2016

OVERVIEW



Fastener 710 and
SolidMaster 801H

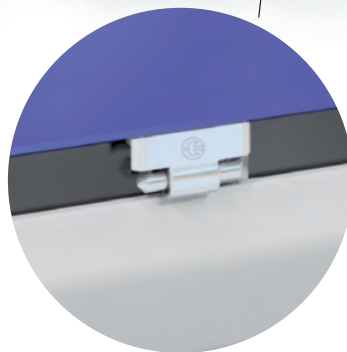

Hinge 655N



Fastener 681S10

- **Hinged pillars – SolidMaster 801 and 802**
- **Aluminium hinged pillars – SolidMaster 801A**
- **Long-range-bolt fasteners**
- **Flat-bolt fasteners**
- **Tension-bolt fasteners**

HINGED PILLARS – SOLIDMASTER 801, 802

Field of application

The HESTAL SolidMaster 801/802 hinged pillar system is used for open and closed flatbed trailers.

- Hinged pillars for 400, 500, 600, 800, 1000 mm drop-sides
- Hinged pillars with curtainside attachment for vehicles with roof structure
- Series 802 hinged pillars with integrated fasteners

Technology

- The SolidMaster 801 and 802 are available in the lengths 400 mm, 500 mm, 600 mm, 800 mm and 1000 mm
- The models SolidMaster 801 and 801S can be combined with the reliable HESTAL drop-side fasteners 681 and 710. The models: SolidMaster 802 and 802S have integrated and locking drop-side fasteners.
- Robust, secure, and positive-fit connection to the outer frame
- Double safeguard mechanism
- All components are KTL coated
- Different fastening techniques can be used all around the superstructure

Versions

- SolidMaster 801 – Hinged pillar without curtainside attachment
- SolidMaster 801S – Hinged pillar with curtainside attachment
- SolidMaster 801H – Rear pillar
- SolidMaster 801HS – Rear pillar with curtainside attachment
- SolidMaster 802 – Hinged pillar with integrated fasteners
- SolidMaster 802S – Hinged pillar with integrated fasteners & curtainside attachment
- SolidMaster 802H – Rear pillar with integrated fasteners
- SolidMaster 802HS – Rear pillar with integrated fasteners & curtainside attachment
- SolidMaster 802P – Bulkhead pillar with integrated fasteners
- SolidMaster 802R – Variable corner pillar with integrated fasteners

Accessories:

The HESTAL safety drop-side hinges 654N, 655N and 657 complete the modular system.

SOLIDMASTER 801 – WITHOUT CURTAINSIDE ATTACHMENT



Length	Weight	Order no.
400 mm	7.6 kg	6.080.538.00
500 mm	8.1 kg	6.080.460.00
600 mm	8.9 kg	6.080.464.00
800 mm	10.5 kg	6.080.468.00
1000 mm	12.0 kg	6.080.472.00

*Subject to change | Date: July 2016

SOLIDMASTER 801 – WITHOUT CURTAINSIDE ATTACHMENT

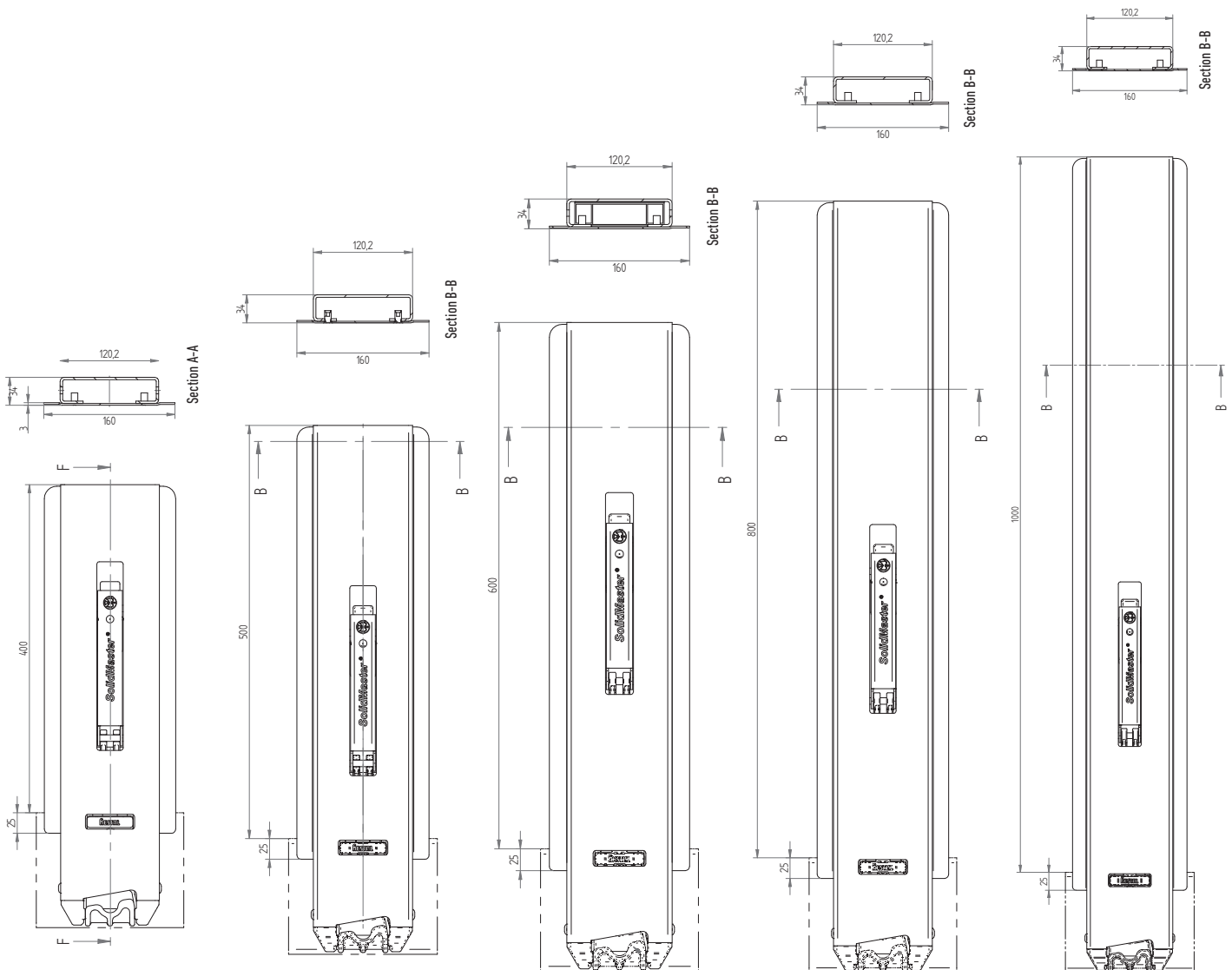

*Subject to change | Date: July 2016

SOLIDMASTER 801S – WITH CURTAINSIDE ATTACHMENT



Length	Weight	Order no.
500 mm	9.5 kg	6.080.462.00
600 mm	10.3 kg	6.080.466.00
800 mm	12.2 kg	6.080.470.00
1000 mm	14.1 kg	6.080.474.00

*Subject to change | Date: July 2016

SOLIDMASTER 801S – WITH CURTAINSIDE ATTACHMENT

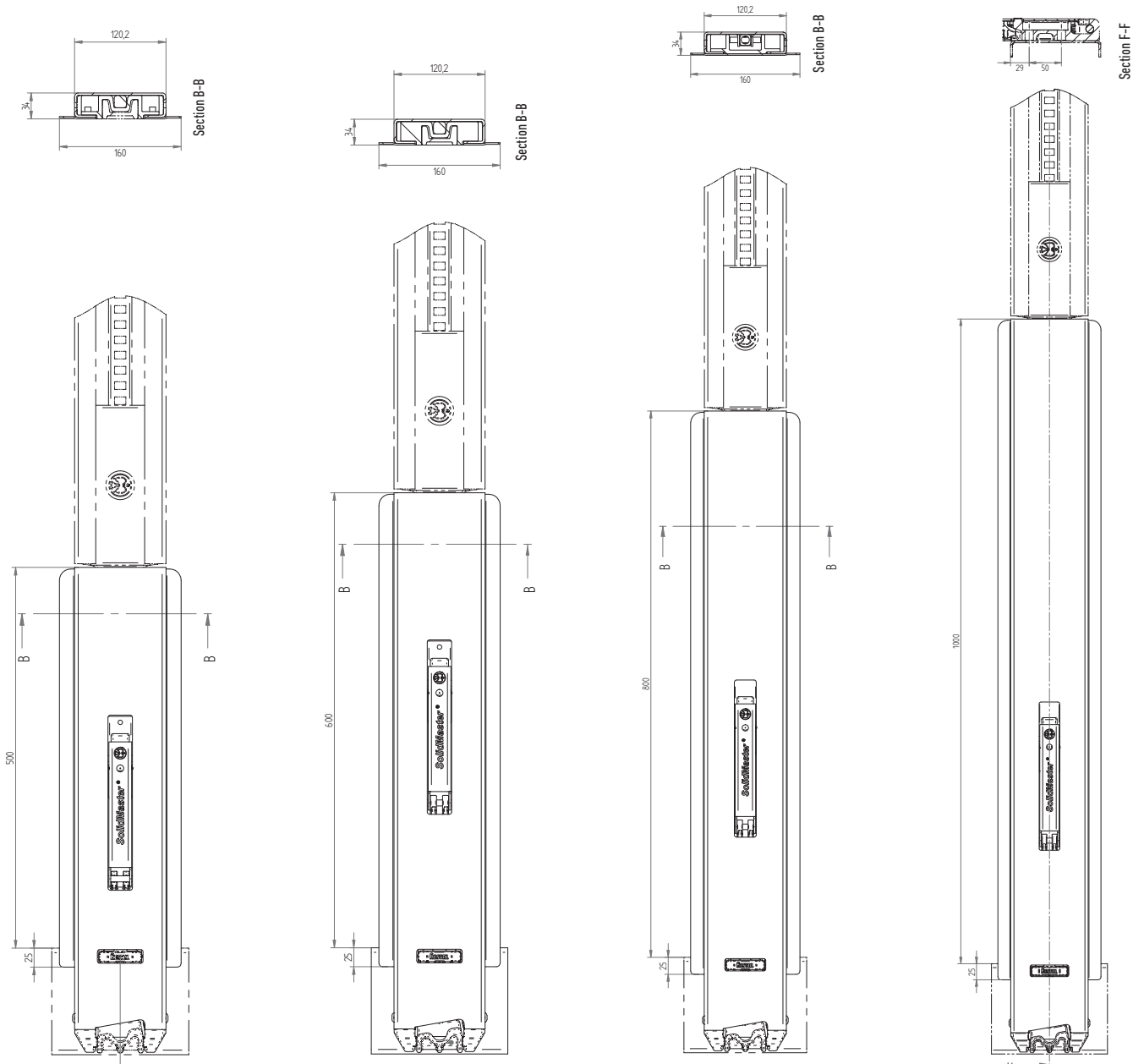

*Subject to change | Date: July 2016

SOLIDMASTER 801H – REAR PILLAR



Length	Side	Weight	Order no.
400 mm	Left	7.228 kg	6.080.550.00
400 mm	Right	7.228 kg	6.080.551.00
500 mm	Left	8.048 kg	6.080.484.00
500 mm	Right	8.048 kg	6.080.485.00
600 mm	Left	9.014 kg	6.080.492.00
600 mm	Right	9.014 kg	6.080.493.00
800 mm	Left	10.467 kg	6.080.500.00
800 mm	Right	10.467 kg	6.080.501.00
1000 mm	Left	11.939 kg	6.080.508.00
1000 mm	Right	11.939 kg	6.080.509.00

*Subject to change | Date: July 2016

SOLIDMASTER 801H – REAR PILLAR

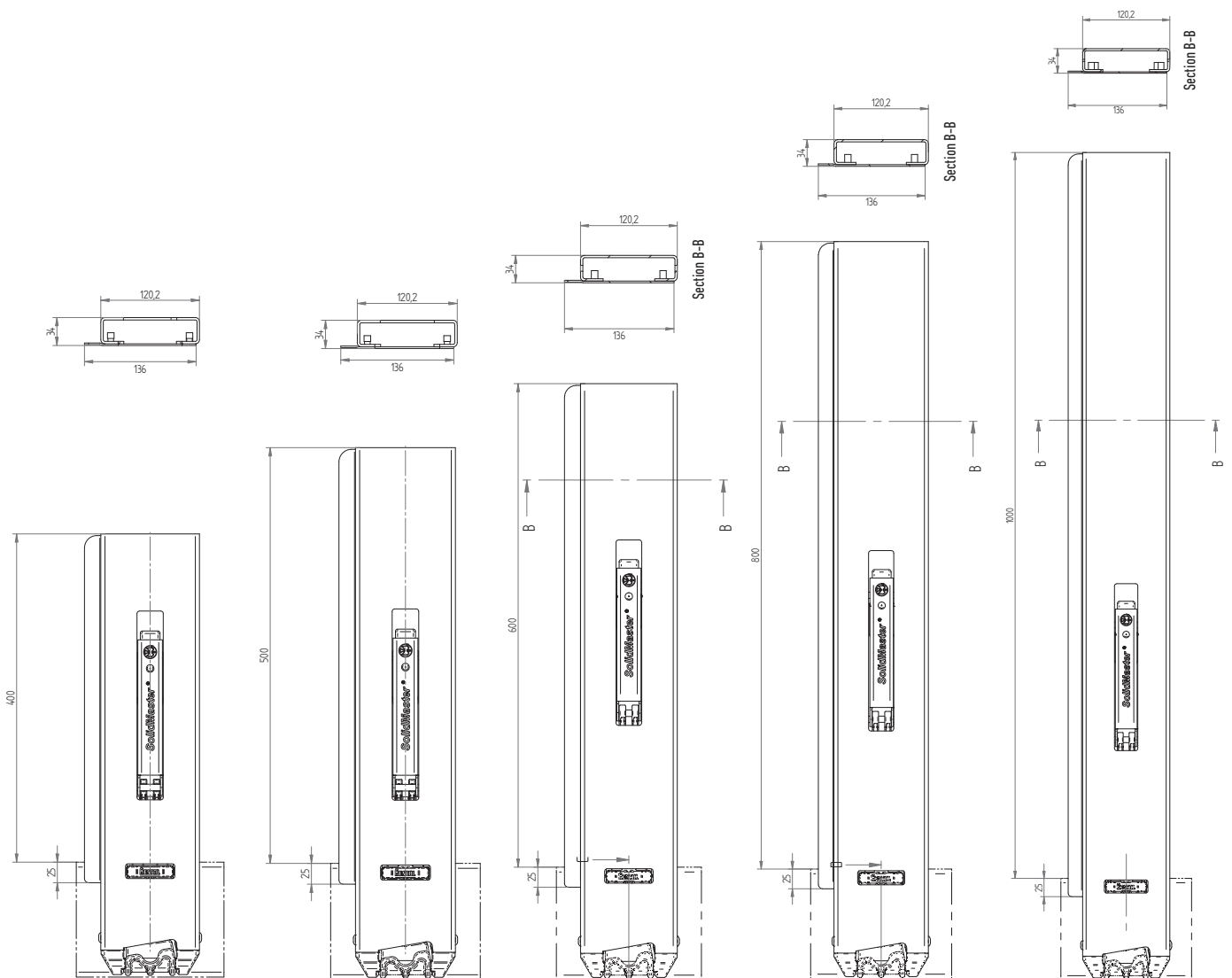

*Subject to change | Date: July 2016

SOLIDMASTER 802 – WITH INTEGRATED FASTENERS

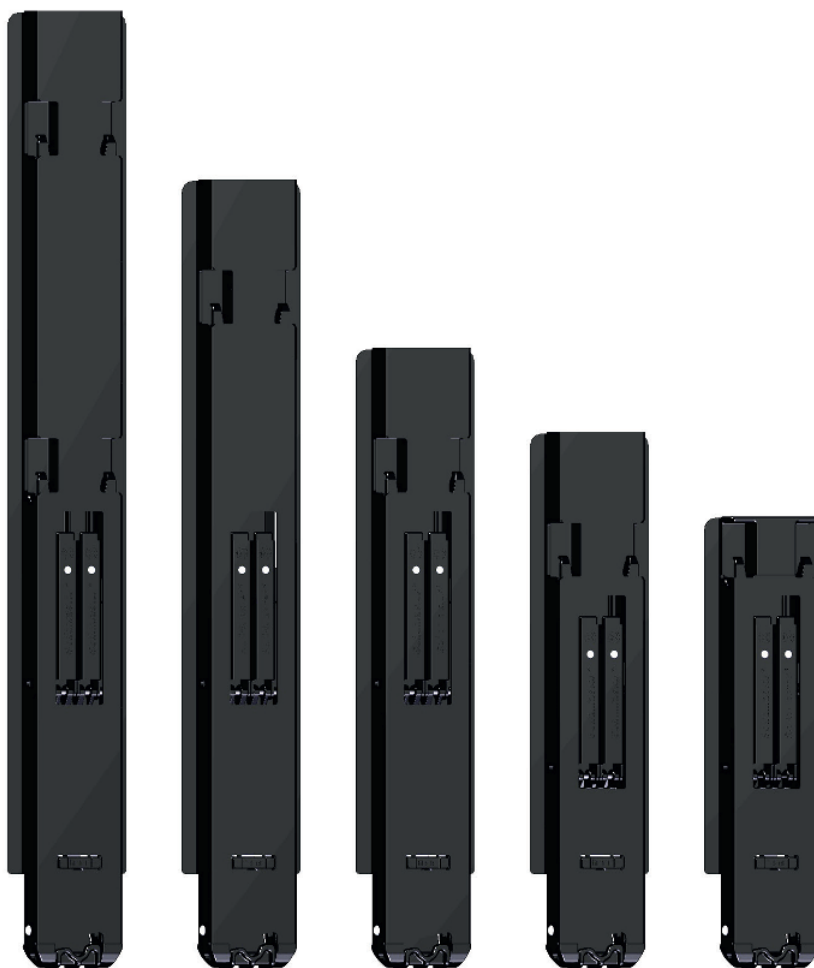

Length	Weight	Order no.
400 mm	8.9 kg	6.080.539.00
500 mm	9.5 kg	6.080.461.00
600 mm	10.4 kg	6.080.465.00
800 mm	12.1 kg	6.080.469.00
1000 mm*	14.8 kg	6.080.473.00

*Double locking mechanism

*Subject to change | Date: July 2016

SOLIDMASTER 802 – WITH INTEGRATED FASTENERS

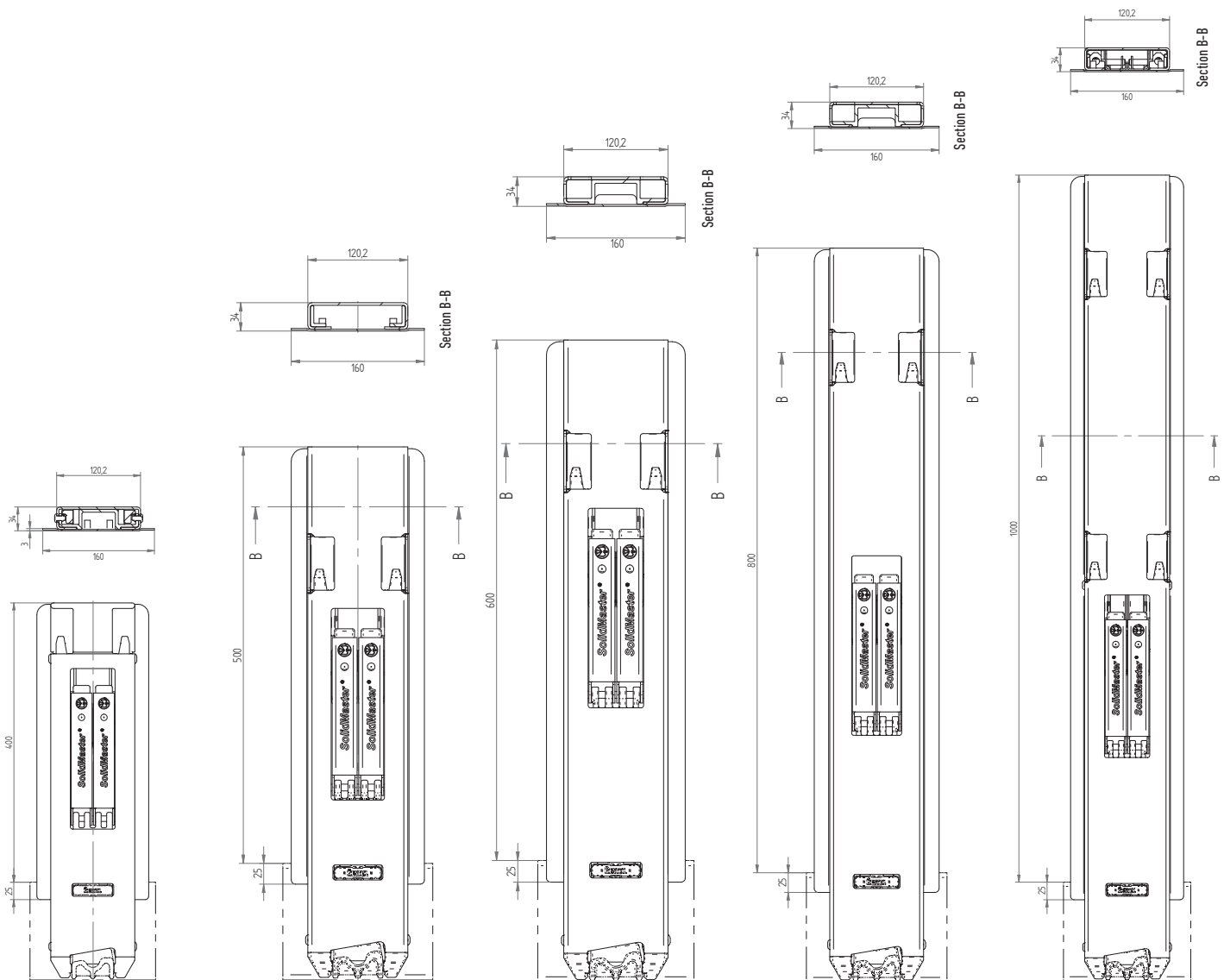

*Subject to change | Date: July 2016

**SOLIDMASTER 802S –
WITH INTEGRATED FASTENERS & CURTAINSIDE ATTACHMENT**



Length	Weight	Order no.
500 mm	9.7 kg	6.080.463.00
600 mm	10.6 kg	6.080.467.00
800 mm	12.6 kg	6.080.471.00
1000 mm	15.3 kg	6.080.475.00

*Subject to change | Date: July 2016

SOLIDMASTER 802S – WITH INTEGRATED FASTENERS & CURTAINSIDE ATTACHMENT

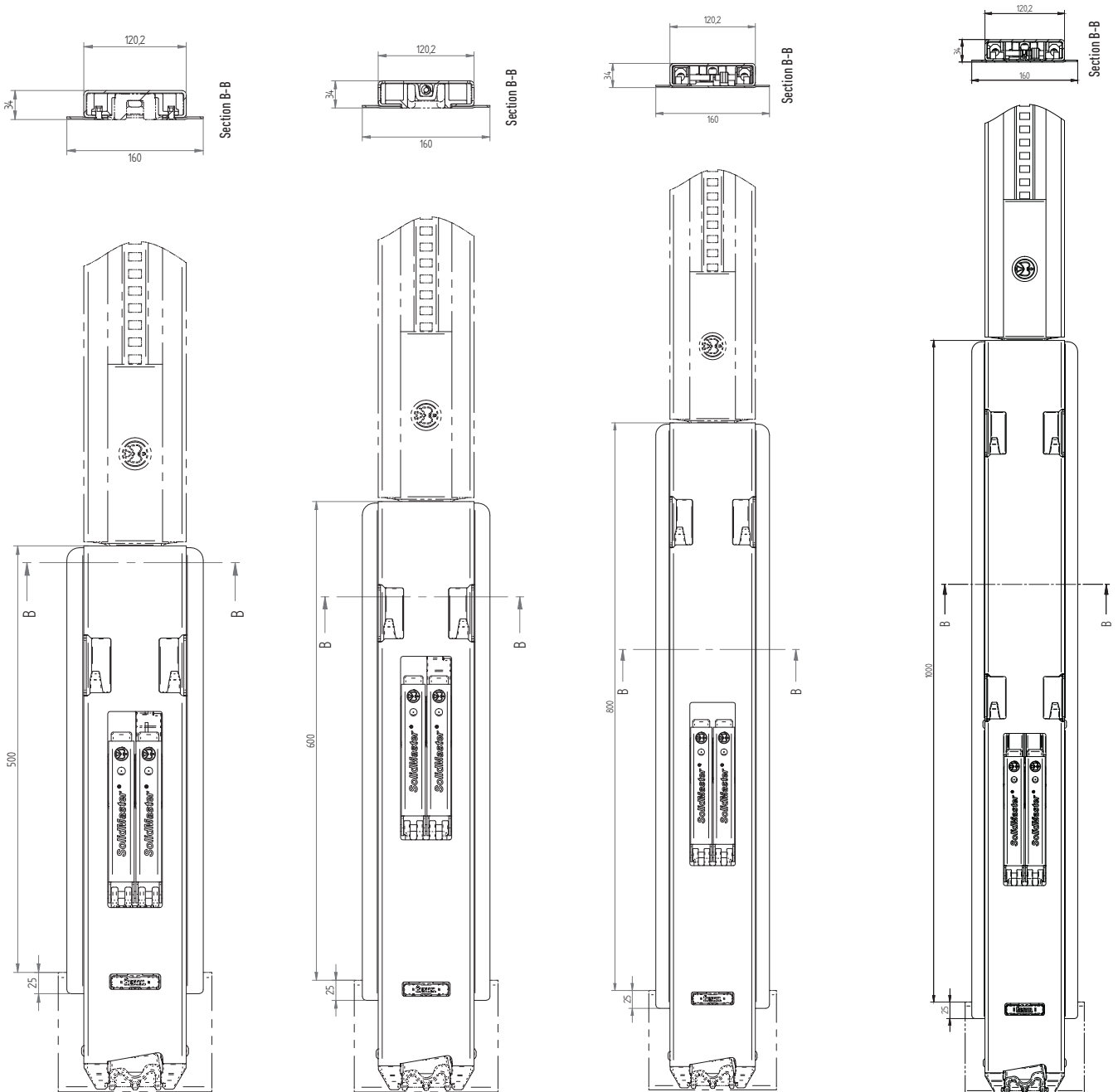

*Subject to change | Date: July 2016

SOLIDMASTER 802H – REAR PILLAR WITH INTEGRATED FASTENERS



Length	Side	Weight	Order no.
400 mm	Left	8.5 kg	6.080.552.00
400 mm	Right	8.5 kg	6.080.553.00
500 mm	Left	9.2 kg	6.080.486.00
500 mm	Right	9.2 kg	6.080.487.00
600 mm	Left	10.1 kg	6.080.494.00
600 mm	Right	10.1 kg	6.080.495.00
800 mm	Left	12.1 kg	6.080.502.00
800 mm	Right	12.1 kg	6.080.503.00
1000 mm*	Left	14.8 kg	6.080.510.00
1000 mm*	Right	14.8 kg	6.080.511.00

*Double locking mechanism

*Subject to change | Date: July 2016

SOLIDMASTER 802H – REAR PILLAR WITH INTEGRATED FASTENERS

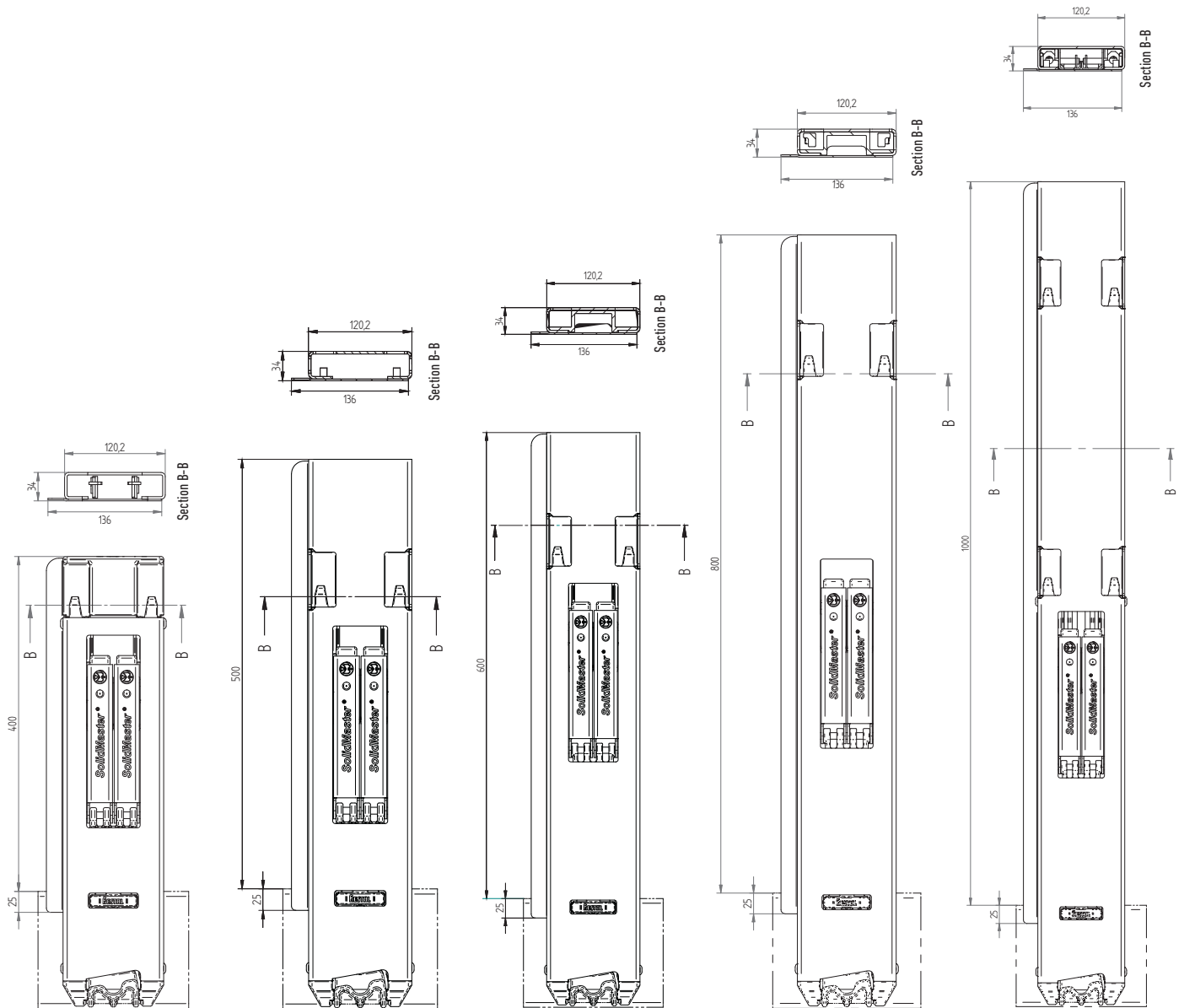

*Subject to change | Date: July 2016

SOLIDMASTER 802HS – REAR PILLAR WITH INTEGRATED FASTENERS & CURTAINSIDE ATTACHMENT

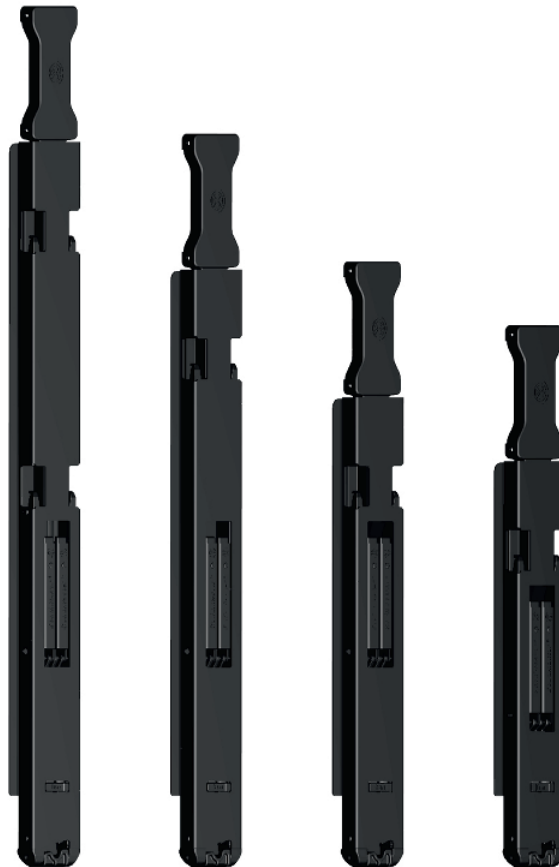

Length	Side	Weight	Order no.
500 mm	Left	9.2 kg	6.080.490.00
500 mm	Right	9.2 kg	6.080.491.00
600 mm	Left	10.1 kg	6.080.498.00
600 mm	Right	10.1 kg	6.080.499.00
800 mm	Left	12.1 kg	6.080.506.00
800 mm	Right	12.1 kg	6.080.507.00
1000 mm	Left	14.8 kg	6.080.514.00
1000 mm	Right	14.8 kg	6.080.515.00

*Subject to change | Date: July 2016

SOLIDMASTER 802HS – REAR PILLAR WITH INTEGRATED FASTENERS & CURTAINSIDE ATTACHMENT

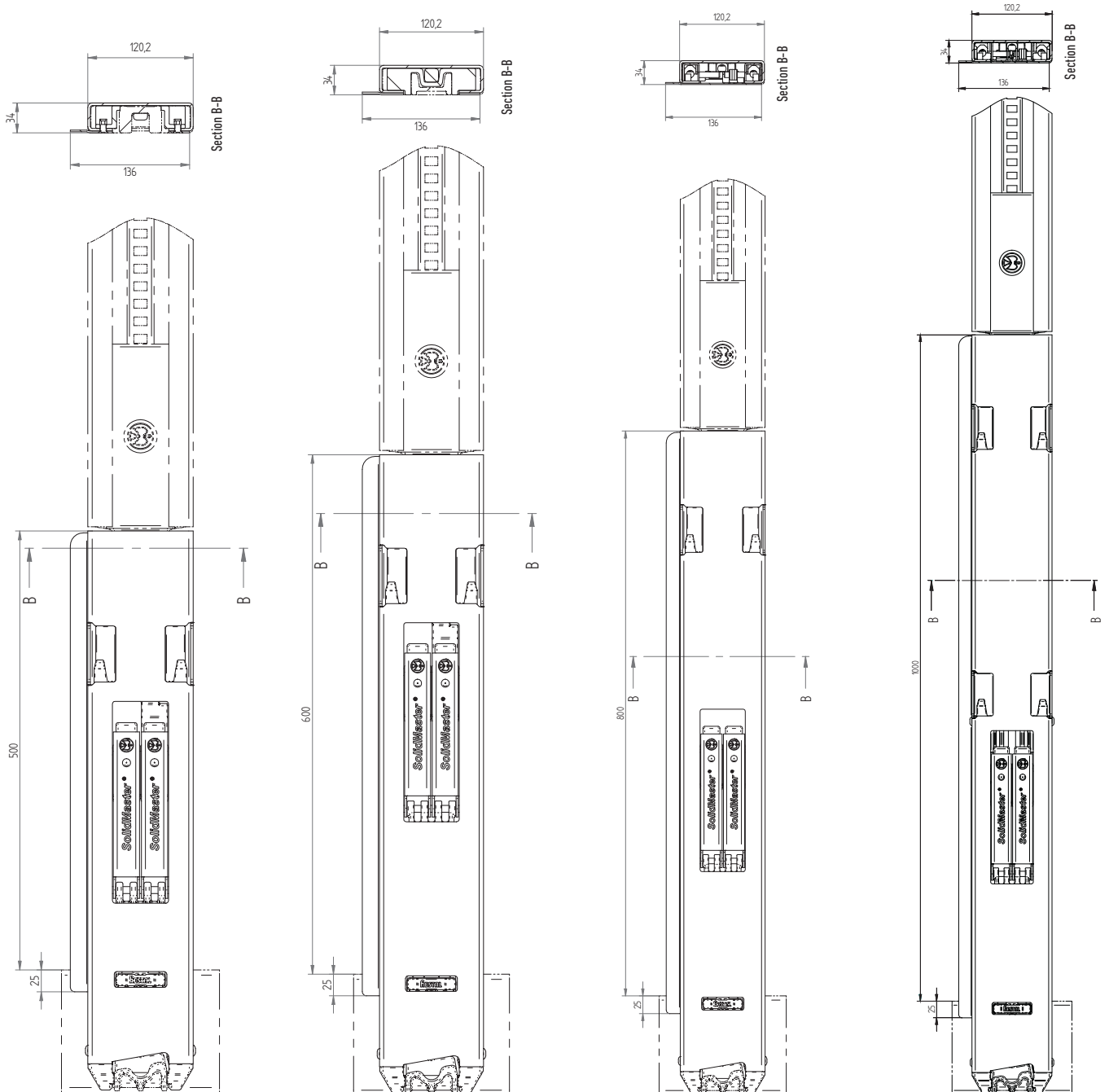

*Subject to change | Date: July 2016

SOLIDMASTER 801, 802 – ACCESSORIES

Figure	Description	Weight	Order no.
	<p>Centring piece Without threaded bore With threaded bore</p>	<p>1.90 kg</p>	<p>6.090.203.99 6.090.203.50</p>
	<p>Centring piece</p>	<p>1.40 kg</p>	<p>6.090.204.99</p>

*Subject to change | Date: July 2016

SOLIDMASTER 801, 802 – ACCESSORIES

Figure	Description	Weight	Order no.
	<p>C profile Length: 1575 mm 1425 mm 1775 mm 1625 mm 1830 mm</p>	<p>8.10 kg 7.30 kg 9.09 kg 8.36 kg 9.39 kg</p>	<p>6.090.182.01 6.090.219.10 6.090.219.20 6.090.219.30 6.090.219.40</p>
	<p>Pillar pocket 801 for fastener 681</p>	<p>0.26 kg</p>	<p>6.071.167.99</p>

*Subject to change | Date: July 2016

SOLIDMASTER 801, 802 – ACCESSORIES

Figure	Description	Weight	Order no.
	<p>801 Pillar bearing M12 M14</p>	<p>0.854 kg</p>	<p>6.090.201.99 6.090.227.00</p>
	<p>801 fastener pocket for fastener 710 Left Right</p>	<p>0.195 kg 0.195 kg</p>	<p>6.071.159.99 6.071.160.99</p>
	<p>801H pillar pocket</p>	<p>0.149 kg</p>	<p>6.071.165.99</p>

*Subject to change | Date: July 2016

SOLIDMASTER 801, 802 – ACCESSORIES

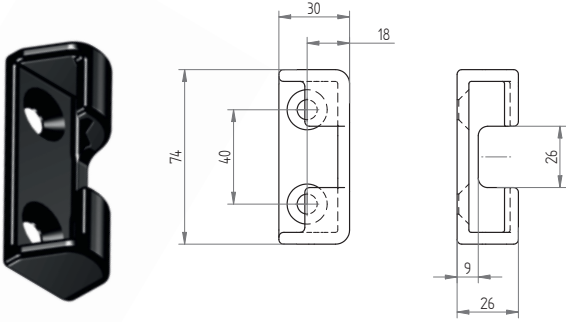
Figure	Description	Weight	Order no.
	<p>801H pillar pocket, high</p>	<p>0.165 kg</p>	<p>6.071.166.00</p>

*Subject to change | Date: July 2016

SOLIDMASTER 801, 801S – ACCESSORIES

Figure	Description	Weight	Order no.
	Threaded plate M8	0.115 kg	6.071.158.00
	Countersunk head screw M8 x 16	0.008 kg	6.071.159.10
	Fastener pocket 802	0.14 kg	6.071.156.99
	Fastener pocket 802H	0.13 kg	6.071.164.99

*Subject to change | Date: July 2016

SOLIDMASTER 802H, 802HS – ACCESSORIES

Figure	Description	Weight	Order no.
	<p>Threaded plate M8</p>	<p>0.029 kg</p>	<p>6.071.157.00</p>
	<p>802 fillister head screw M8 x 16</p>	<p>0.009 kg</p>	<p>6.071.156.10</p>

*Subject to change | Date: July 2016

SOLIDMASTER 802P – BULKHEAD PILLAR WITH INTEGRATED FASTENERS



Length	Side	Weight (kg)	Order no.
400 mm	Left	3.8 kg	6.080.574.00
400 mm	Right	3.8 kg	6.080.575.00
500 mm	Left	4.4 kg	6.080.518.00
500 mm	Right	4.4 kg	6.080.519.00
600 mm	Left	4.9 kg	6.080.516.00
600 mm	Right	4.9 kg	6.080.517.00
800 mm	Left	6.0 kg	6.080.520.00
800 mm	Right	6.0 kg	6.080.521.00
1000 mm	Left	7.0 kg	6.080.522.00
1000 mm	Right	7.0 kg	6.080.523.00
1000 mm*	Left	8.2 kg	6.080.524.00
1000 mm*	Right	8.2 kg	6.080.525.00

* Double locking mechanism

*Subject to change | Date: July 2016

SOLIDMASTER 802P – BULKHEAD PILLAR WITH INTEGRATED FASTENERS

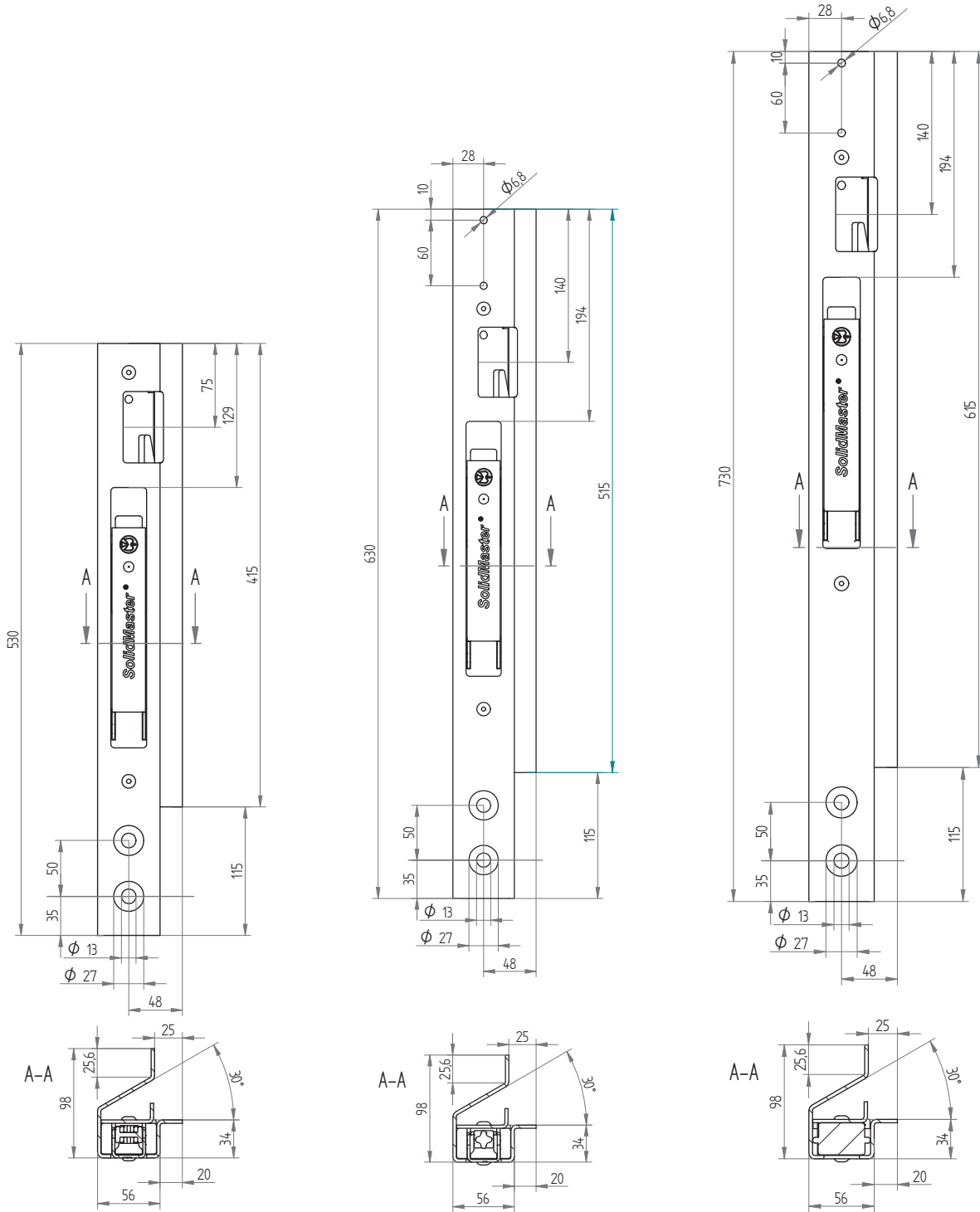

*Subject to change | Date: July 2016

SOLIDMASTER 802P – BULKHEAD PILLAR WITH INTEGRATED FASTENERS

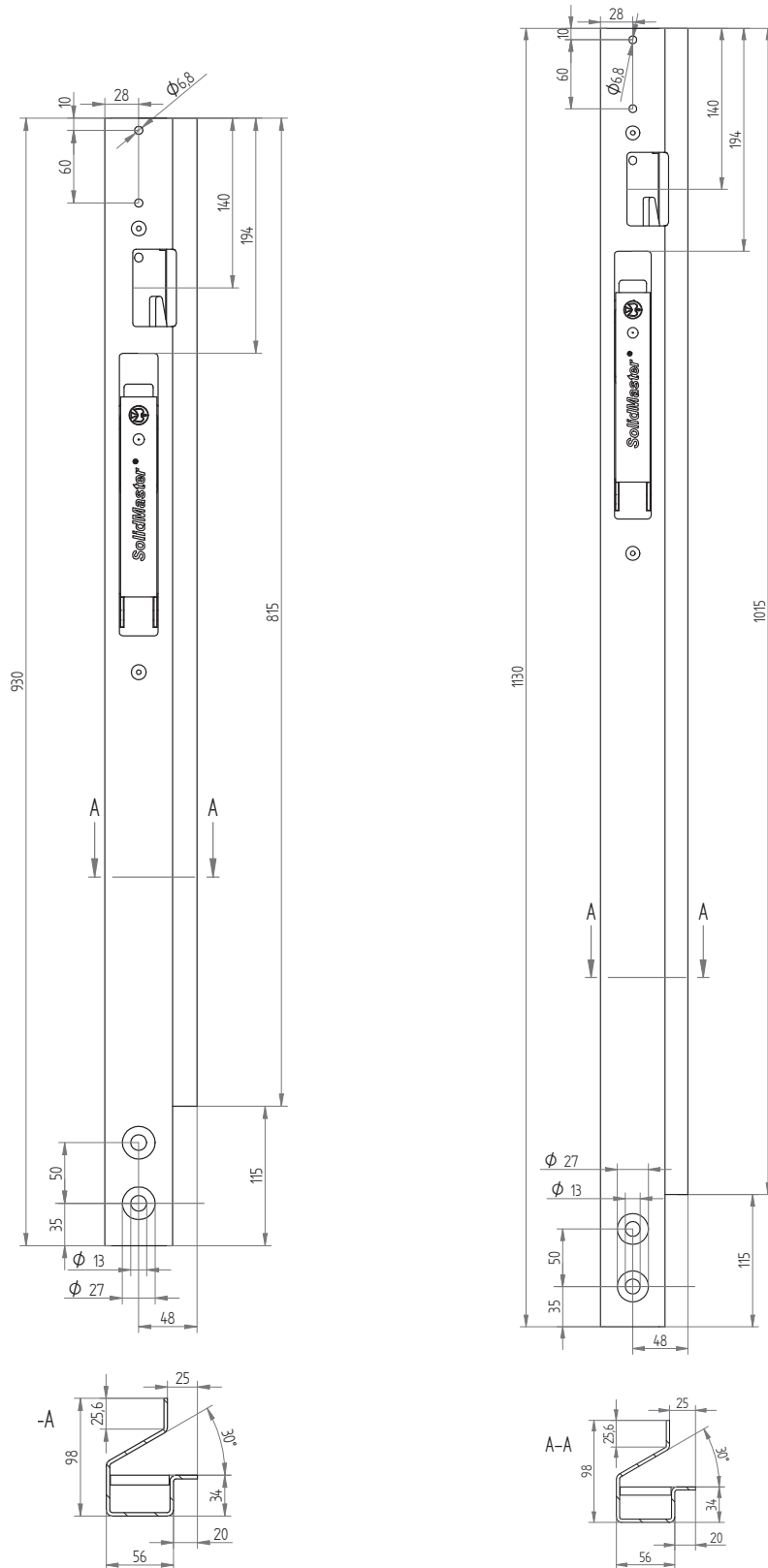

*Subject to change | Date: July 2016

SOLIDMASTER 802R – VARIABLE CORNER PILLAR WITH INTEGRATED FASTENERS

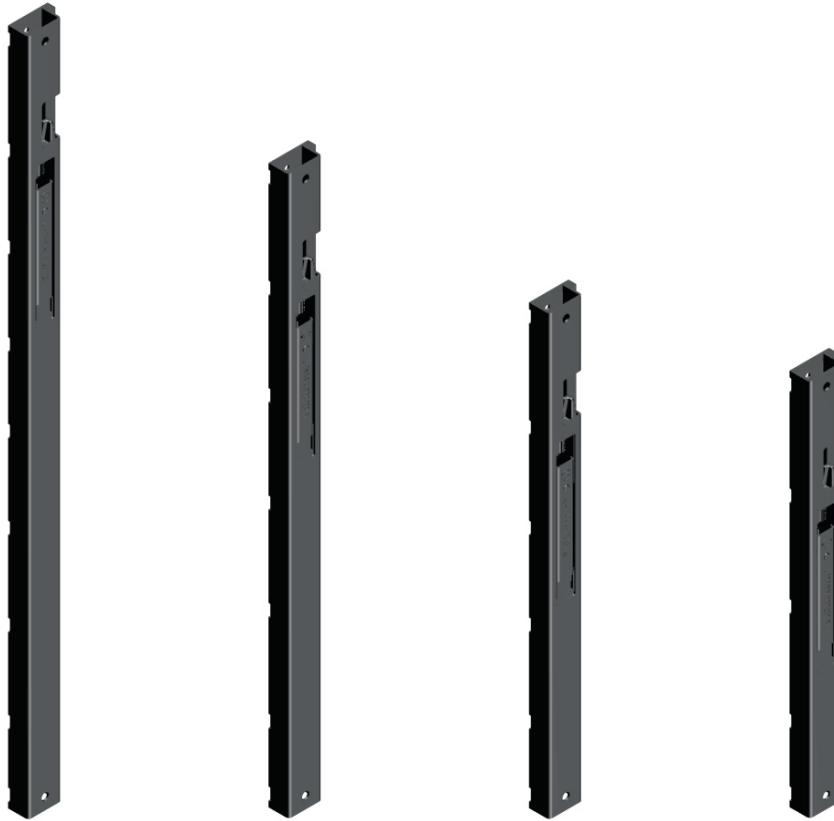

Length	Side	Weight	Order no.
500 mm	Left	3.2 kg	6.080.526.00
500 mm	Right	3.2 kg	6.080.527.00
600 mm	Left	3.6 kg	6.080.528.00
600 mm	Right	3.6 kg	6.080.529.00
800 mm	Left	4.5 kg	6.080.530.00
800 mm	Right	5.3 kg	6.080.531.00
1000 mm	Left	5.3 kg	6.080.532.00
1000 mm	Right	7.0 kg	6.080.533.00
1000 mm*	Left	6.1 kg	6.080.534.00
1000 mm*	Right	6.1 kg	6.080.535.00

* Double locking mechanism

*Subject to change | Date: July 2016

SOLIDMASTER 802R – VARIABLE CORNER PILLAR WITH INTEGRATED FASTENERS

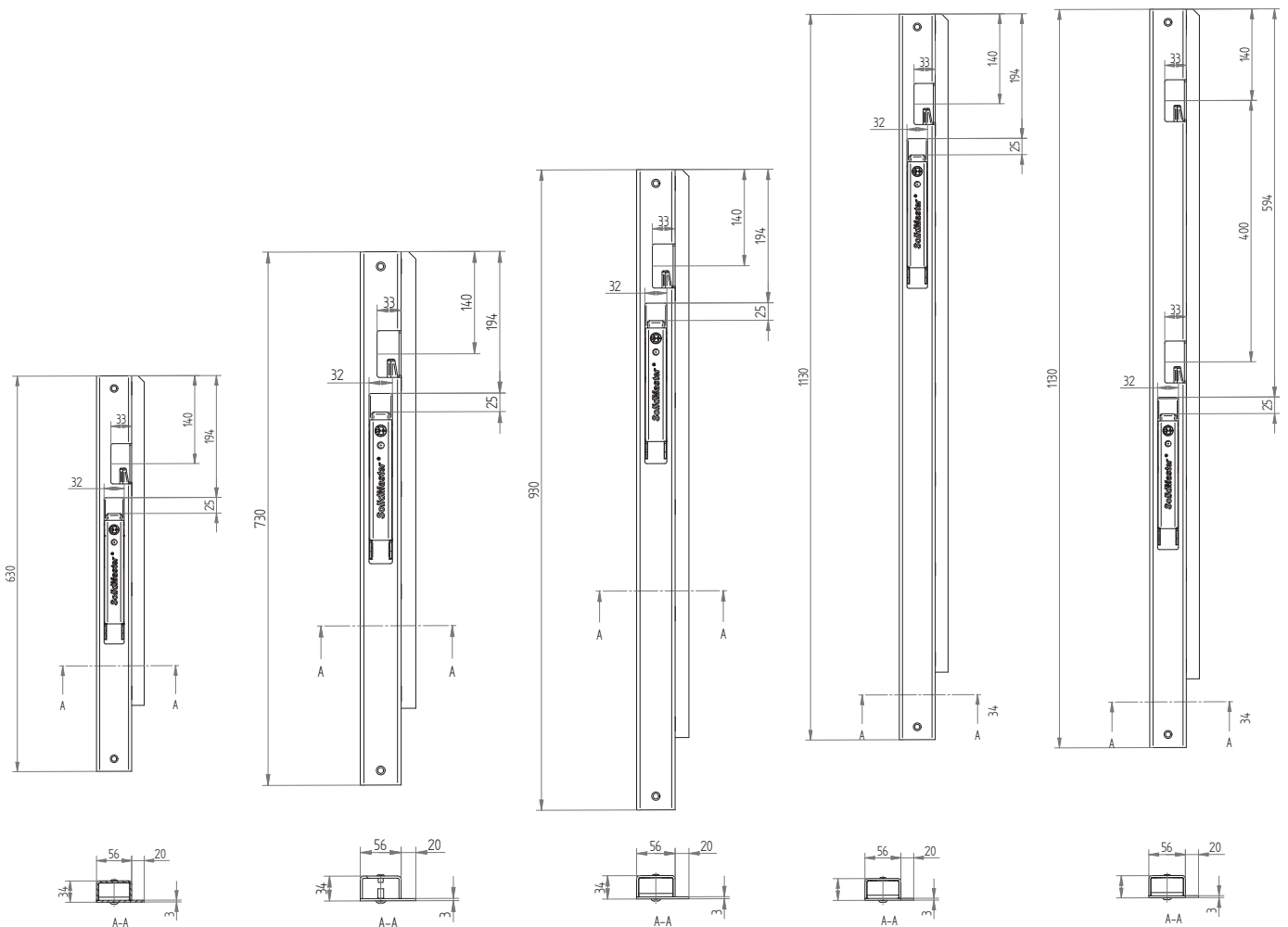

*Subject to change | Date: July 2016

SOLIDMASTER 802R, 802P – ACCESSORIES

Figure	Description	Weight	Order no.
	Fastener pocket 802	0.14 kg	6.071.156.99
	Threaded plate	0.029 kg	6.071.157.00
	Fillister head screw	0.009 kg	6.071.156.10

*Subject to change | Date: July 2016

SOLIDMASTER 802R, 802P – ACCESSORIES

Figure	Description	Weight	Order no.
	<p>802P extension profile for bulkhead pillar, 2160 mm</p>	<p>8.2 kg</p>	<p>6.090.211.01</p>
	<p>802P adapter for bulkhead pillar extension</p>	<p>0.52 kg</p>	<p>6.090.211.02</p>
	<p>Pocket set 802 (bolt-on)</p>	<p>0.2 kg</p>	<p>6.850.054.00</p>

*Subject to change | Date: July 2016

ALUMINIUM HINGED PILLARS – SOLIDMASTER 801A

Fields of application

The HESTAL SolidMaster 801 Aluminium hinged pillar system is used for open and closed flatbed trailers.

- Hinged pillars for 400 mm, 500 mm, 600 mm, 800 mm, 1000 mm drop-sides
- Hinged pillars with curtainside attachment for vehicles with roof structure
- Series 802 hinged pillar with integrated fasteners

Technology

- The SolidMaster 801A is available in the lengths 400 mm, 500 mm, 600 mm, 800 mm and 1000 mm
- The SolidMaster 801A can be combined with the reliable HESTAL drop-side fasteners 681 and 710.
- Robust, secure, and positive-fit connection to the outer frame
- Double safeguard mechanism
- All steel parts are KTL coated
- Different fastening techniques can be used all around the superstructure

Aluminium versions

- SolidMaster 801A – Aluminium hinged pillar without curtainside attachment
- SolidMaster 801AS – Aluminium hinged pillar with curtainside attachment
- SolidMaster 801AH – Aluminium rear pillar
- SolidMaster 801AHS – Aluminium rear pillar with curtainside attachment

Accessories:

The HESTAL safety drop-side hinges 654N, 655N and 657 complete the modular system.

SOLIDMASTER 801A – ALUMINIUM HINGED PILLAR WITHOUT CURTAINSIDE ATTACHMENT

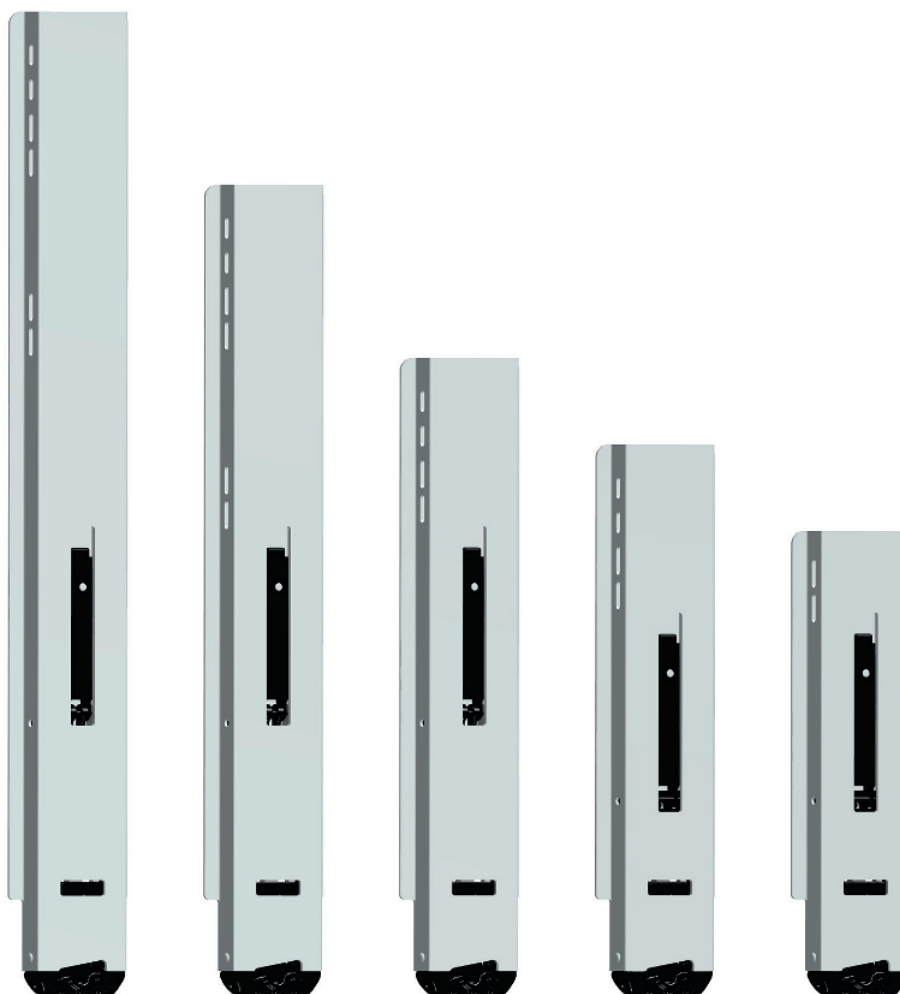

Length	Weight	Order no.
400 mm	6.43 kg	6.080.588.00
500 mm	6.75 kg	6.080.589.00
600 mm	7.26 kg	6.080.590.00
800 mm	7.9 kg	6.080.591.00
1000 mm	8.54 kg	6.080.592.00

*Subject to change | Date: July 2016

SOLIDMASTER 801A – ALUMINIUM HINGED PILLAR WITHOUT CURTAINSIDE ATTACHMENT

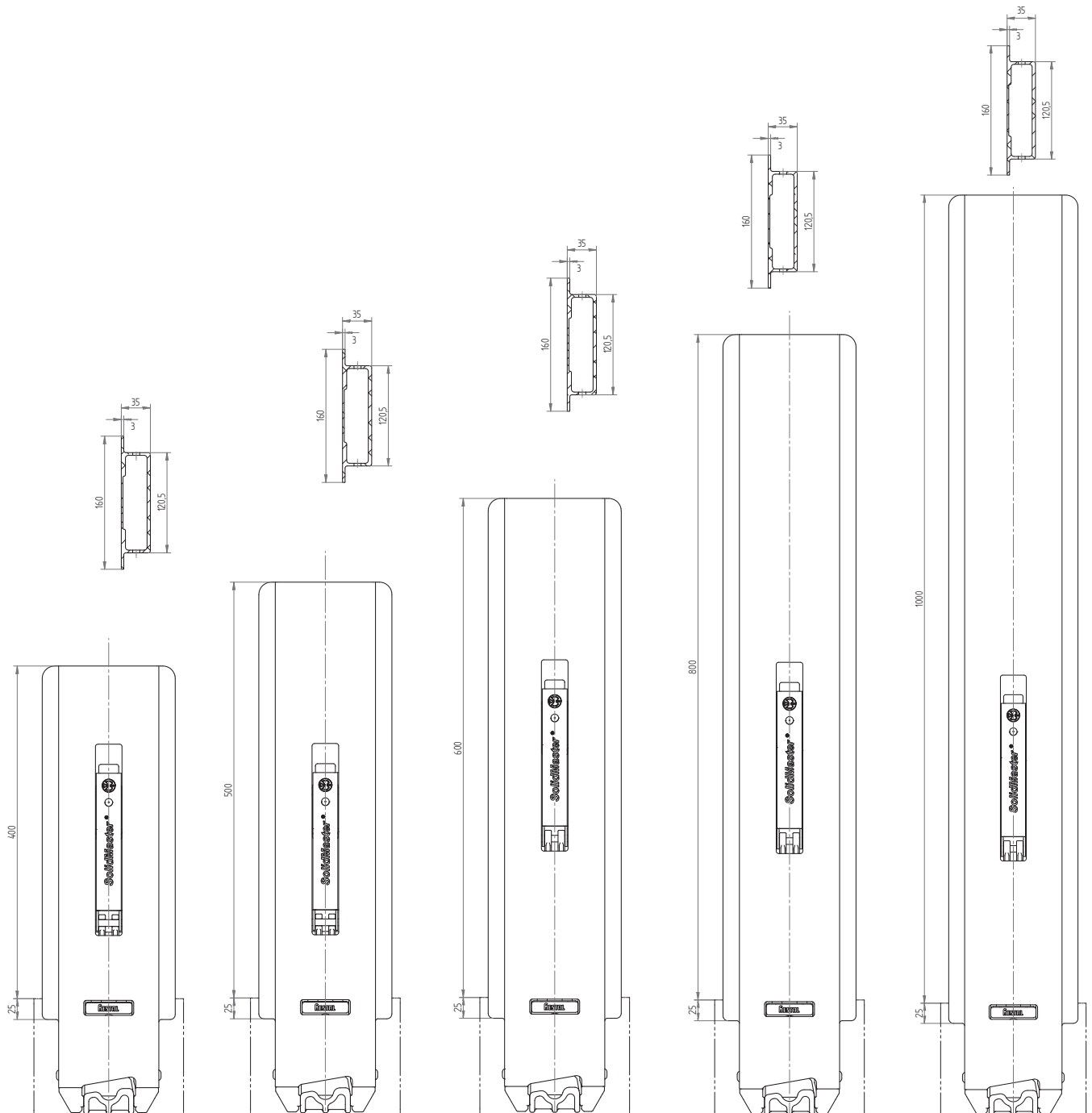

*Subject to change | Date: July 2016

SOLIDMASTER 801AS – ALUMINIUM HINGED PILLAR WITH CURTAINSIDE ATTACHMENT

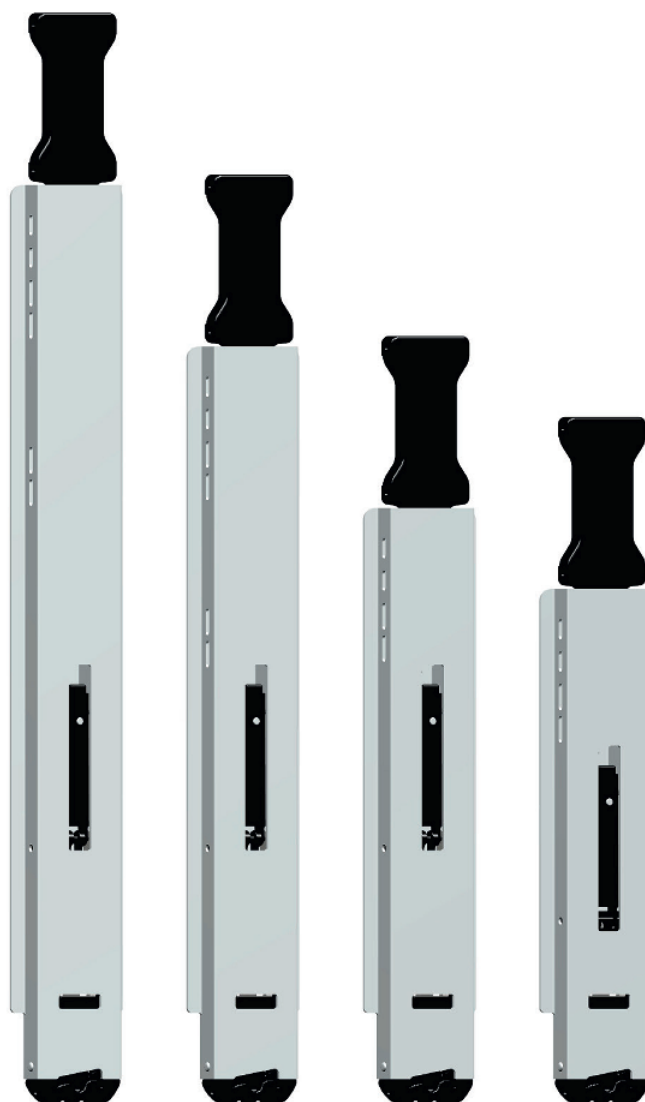

Length	Weight	Order no.
500 mm	12.1 kg	6.080.603.00
600 mm	12.7 kg	6.080.604.00
800 mm	13.2 kg	6.080.605.00
1000 mm	14.66 kg	6.080.606.00

*Subject to change | Date: July 2016

SOLIDMASTER 801AS – ALUMINIUM HINGED PILLAR WITH CURTAINSIDE ATTACHMENT

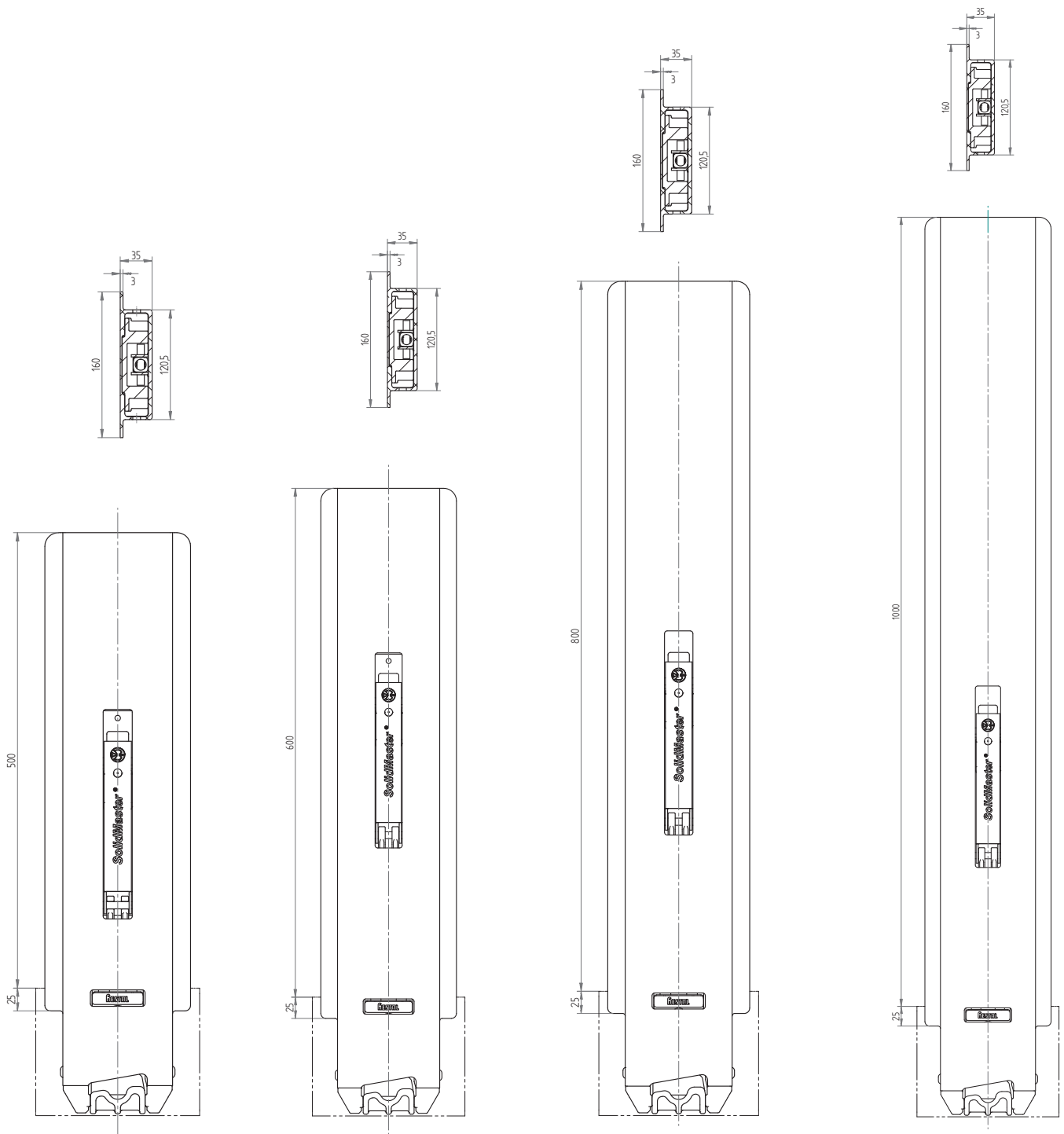

*Subject to change | Date: July 2016

SOLIDMASTER 801AH – ALUMINIUM REAR PILLAR

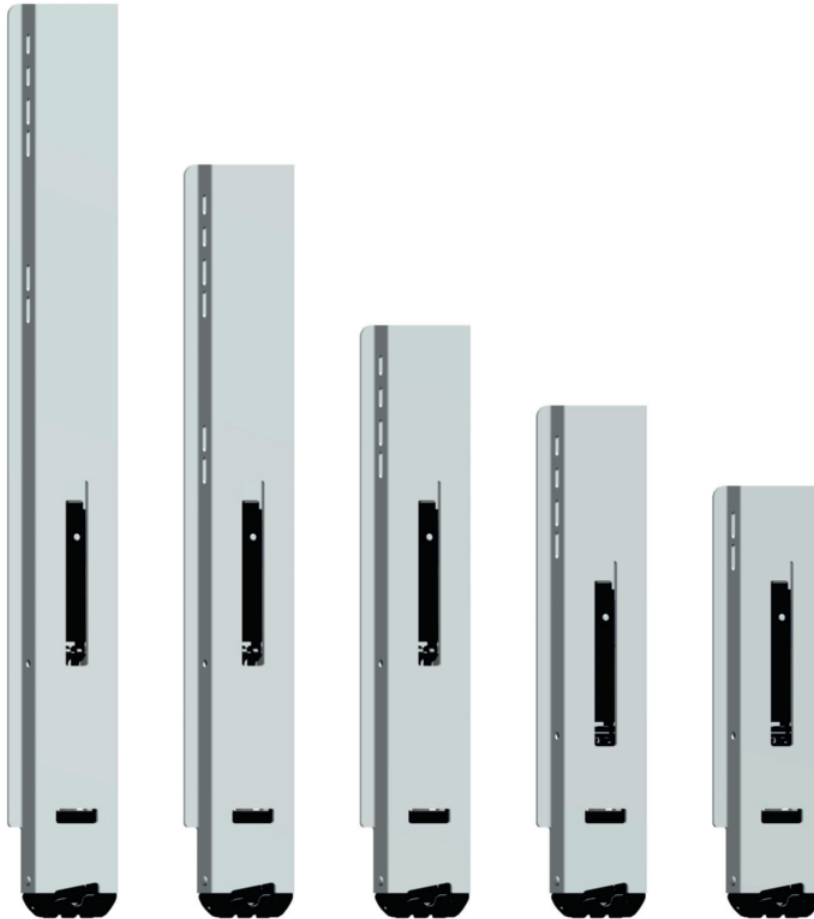

Length	Side	Weight	Order no.
400 mm	Left	6.36 kg	6.080.593.00
400 mm	Right	6.36 kg	6.080.594.00
500 mm	Left	6.66 kg	6.080.595.00
500 mm	Right	6.66 kg	6.080.596.00
600 mm	Left	7.15 kg	6.080.597.00
600 mm	Right	7.15 kg	6.080.598.00
800 mm	Left	7.76 kg	6.080.599.00
800 mm	Right	7.76 kg	6.080.600.00
1000 mm	Left	8.37 kg	6.080.601.00
1000 mm	Right	8.37 kg	6.080.602.00

*Subject to change | Date: July 2016

SOLIDMASTER 801AH – ALUMINIUM REAR PILLAR

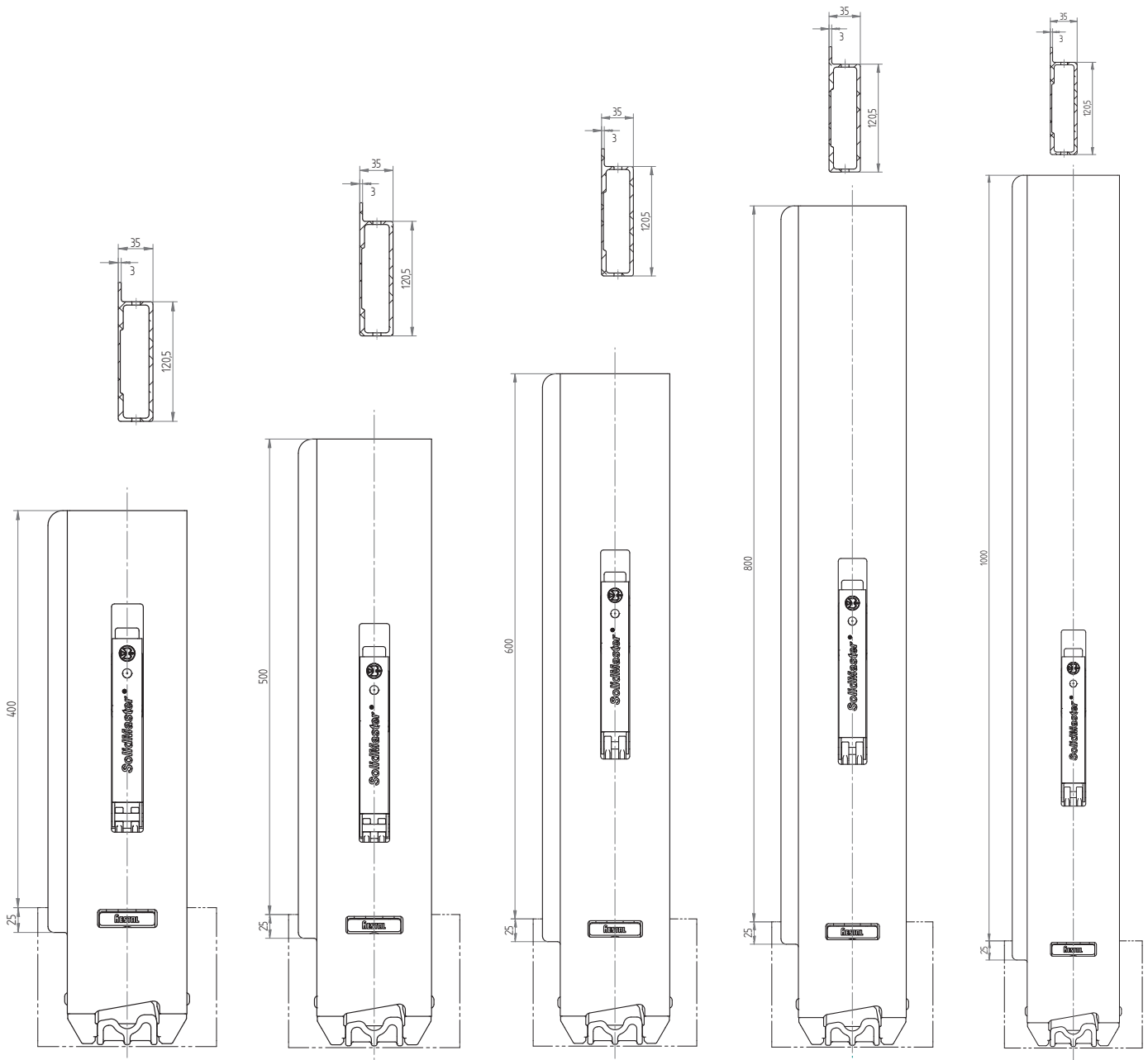

*Subject to change | Date: July 2016

SOLIDMASTER 801AHS – ALUMINIUM REAR PILLAR WITH CURTAINSIDE ATTACHMENT



Length	Side	Weight	Order no.
500 mm	Left	12.1 kg	6.080.607.00
500 mm	Right	12.1 kg	6.080.608.00
600 mm	Left	12.59 kg	6.080.609.00
600 mm	Right	12.59 kg	6.080.610.00
800 mm	Left	13.06 kg	6.080.611.00
800 mm	Right	13.06 kg	6.080.612.00
1000 mm	Left	14.49 kg	6.080.613.00
1000 mm	Right	14.49 kg	6.080.614.00

*Subject to change | Date: July 2016

SOLIDMASTER 801AHS – ALUMINIUM REAR PILLAR WITH CURTAINSIDE ATTACHMENT

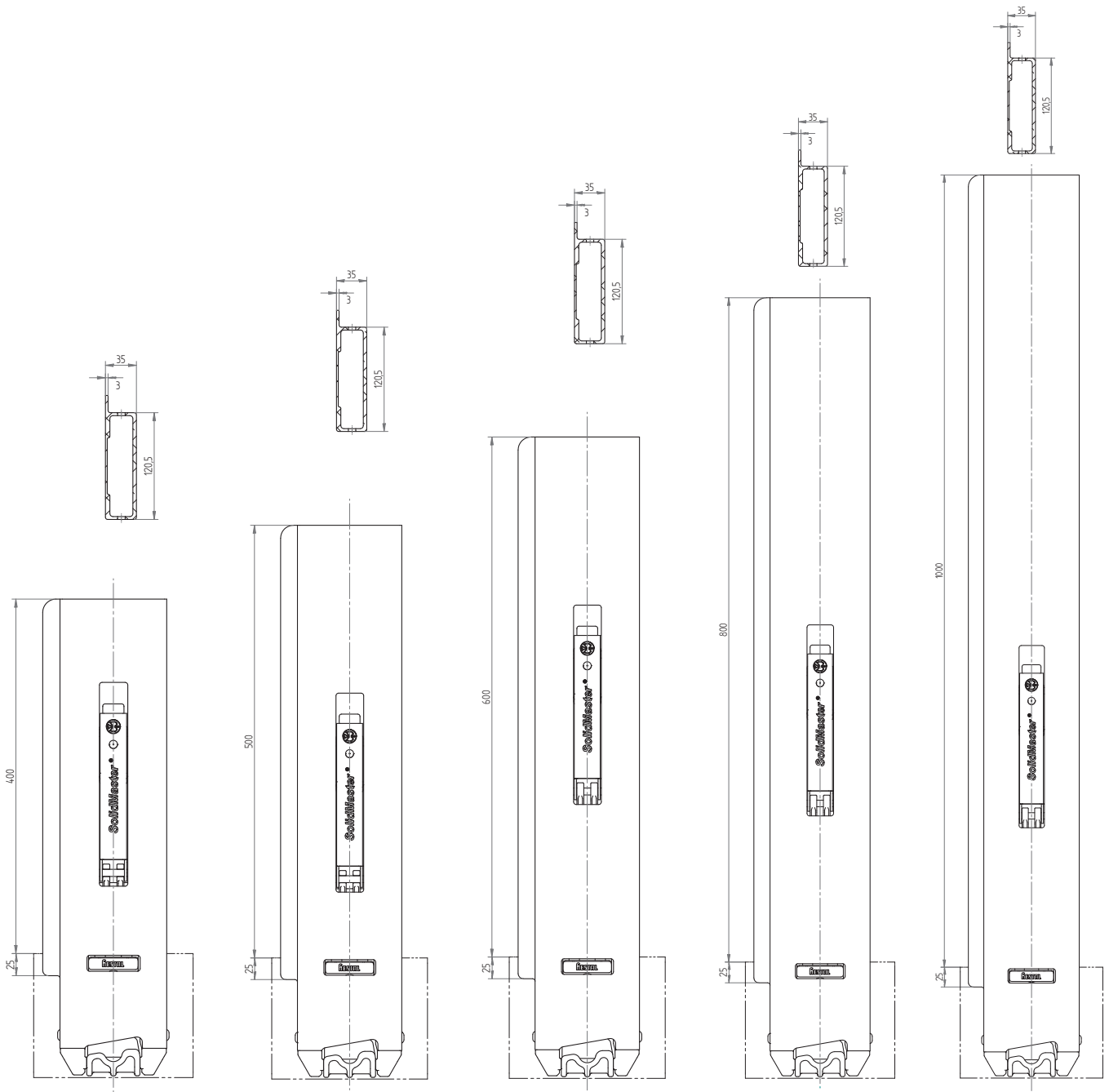

*Subject to change | Date: July 2016

OVERVIEW

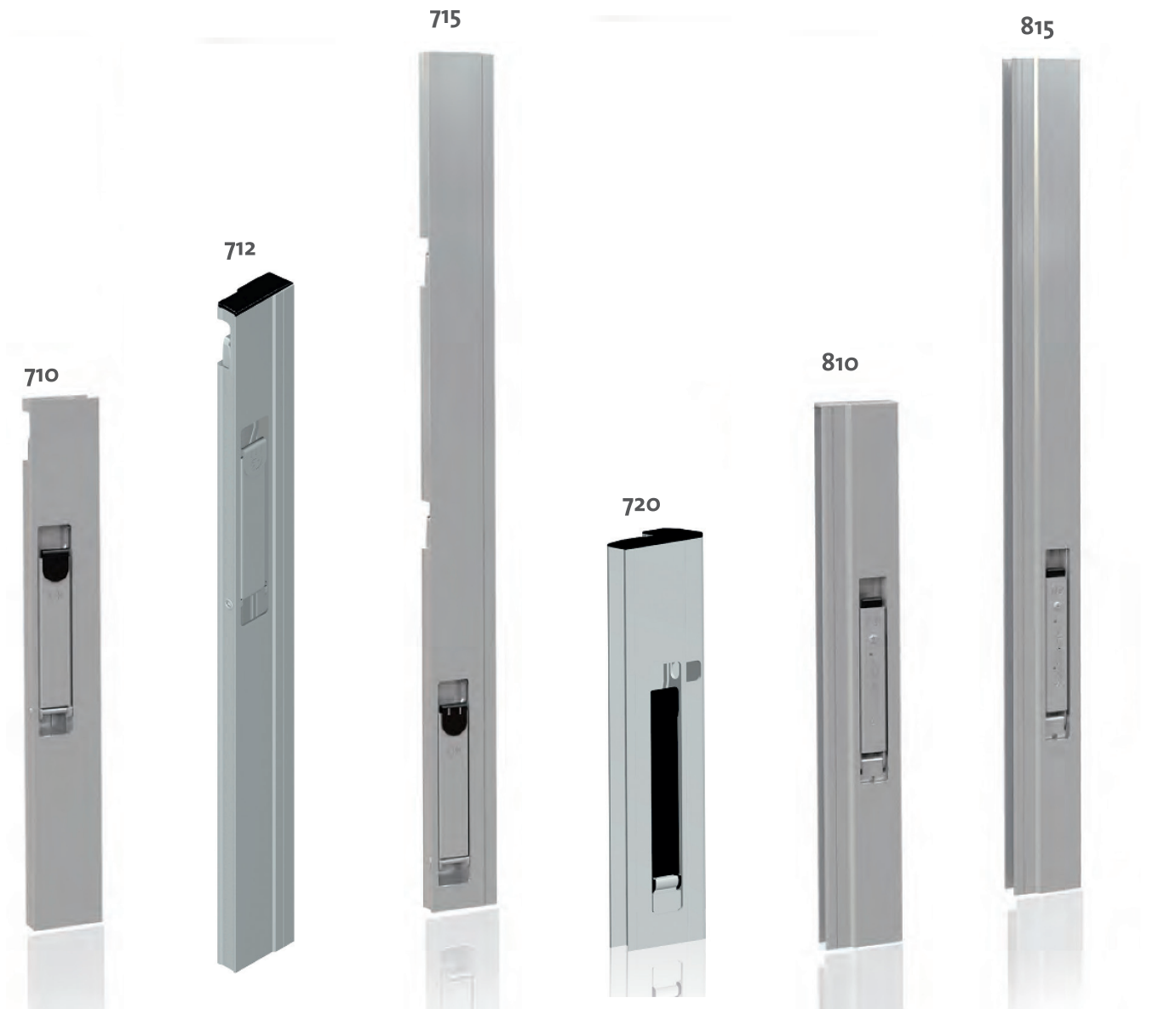

*Subject to change | Date: July 2016

FLATBED SUPERSTRUCTURE

LONG-RANGE-BOLT FASTENER 710

For drop-side vehicles, single lock; the locked position of the locking unit is held by an over-dead-center and a button locking device. Easy to install, easy to operate. Also available as customs version.

Typical fields of application

- For 400 mm - 800 mm drop-sides
- The 710 fastener can be combined with the HESTAL SolidMaster hinged pillar system
- Depending on the installation situation and profile design, the 710 or 712 fastener is used, the 710 fastener has a plain front and an offset for the pillar connection at the back

Technology

- Good closing behaviour thanks to interaction between pocket and bolt
- Automatic adjustment
- The hand lever folds in when the drop-side is lowered
- Unlocking and locking are both possible under cargo pressure
- Cargo pressure detection by traction between bolt and pillar pocket
- Above 600 mm profile height the hand lever is covered by the tarpaulin
- A special profile variant with lateral inspection openings for customs-specified drop-side locking is available as an option for the 710 fastener

Versions

Lock mechanism hot-dip galvanised to FHS-TL 9.01

Aluminium profiles: available in various surface finishes, e.g. raw or anodised

Accessories

710.20 Pillar pocket, raw, for welding

SolidMaster pillar pocket for bolting

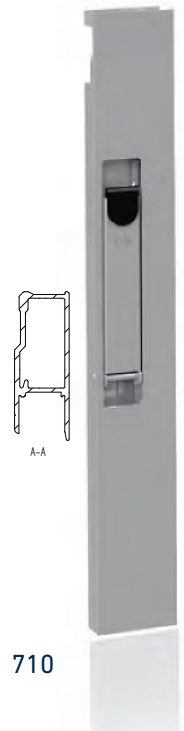
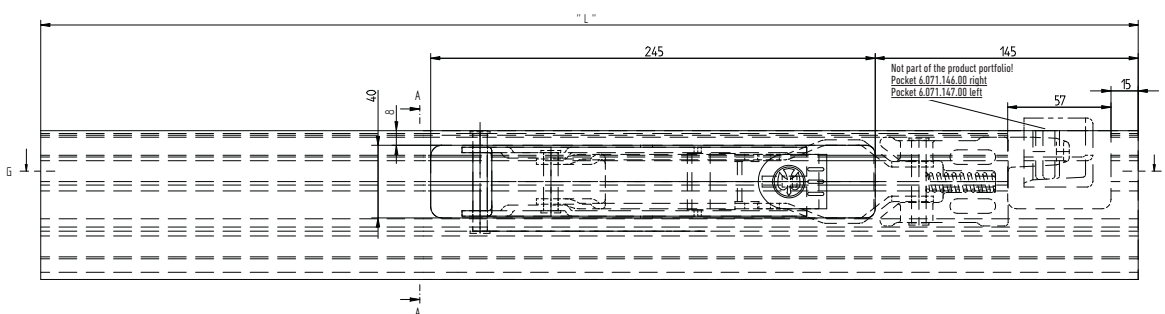

710

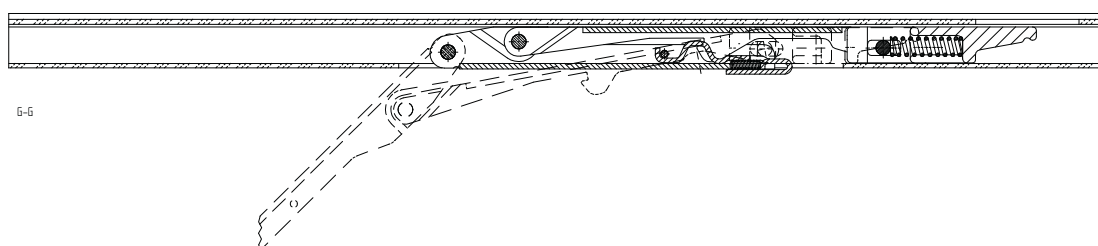

*Subject to change | Date: July 2016

LONG-RANGE-BOLT FASTENER 710

Type	Description	Length	Weight	Order no.
710	Hand lever locking part without bezel, left		0.81 kg	6.020.741.00
710	Hand lever locking part without bezel, right		0.81 kg	6.020.740.00
710.4	Lock in profile left, profile raw	400 mm	1.36 kg	6.021.601.00
710.4	Lock in profile right, profile raw	400 mm	1.36 kg	6.021.600.00
710.4	Lock in profile left, profile raw	415 mm	1.38 kg	6.020.749.00
710.4	Lock in profile right, profile raw	415 mm	1.38 kg	6.020.748.00
710.5	Lock in profile left, profile raw	500 mm	1.50 kg	6.021.669.00
710.5	Lock in profile right, profile raw	500 mm	1.50 kg	6.021.668.00
710.5	Lock in profile left, profile raw	515 mm	1.52 kg	6.020.781.00
710.5	Lock in profile right, profile raw	515 mm	1.52 kg	6.020.780.00
710.5	Lock in profile left, profile raw with PA strip	515 mm	1.51 kg	6.021.579.00
710.5	Lock in profile right, profile raw with PA strip	515 mm	1.51 kg	6.021.580.00
710.6	Lock in profile left, profile raw	600 mm	1.65 kg	6.020.854.00
710.6	Lock in profile right, profile raw	600 mm	1.65 kg	6.020.853.00
710.6	Lock in profile left, profile raw	615 mm	1.67 kg	6.020.751.00
710.6	Lock in profile right, profile raw	615 mm	1.67 kg	6.020.750.00
710.6	Lock in profile left, profile raw with PA strip	615 mm	1.65 kg	6.021.581.00
710.6	Lock in profile right, profile raw with PA strip	615 mm	1.65 kg	6.021.582.00
710.7	Lock in profile left, profile raw	715 mm	1.82 kg	6.021.577.00
710.7	Lock in profile right, profile raw	715 mm	1.82 kg	6.021.578.00
710.8	Lock in profile left, profile raw	800 mm	1.94 kg	6.020.883.00
710.8	Lock in profile right, profile raw	800 mm	1.94 kg	6.020.882.00
710.8	Lock in profile left, profile raw	815 mm	1.96 kg	6.020.753.00
710.8	Lock in profile right, profile raw	815 mm	1.96 kg	6.020.752.00
710.8	Lock in profile left, profile raw with PA strip	815 mm	1.94 kg	6.021.583.00
710.8	Lock in profile right, profile raw with PA strip	815 mm	1.94 kg	6.021.584.00
710.10	Lock in profile left, profile raw	1015 mm	2.26 kg	6.020.816.00
710.10	Lock in profile right, profile raw	1015 mm	2.26 kg	6.020.815.00
710.20	Pillar pocket, raw left		0.12 kg	6.071.147.99
710.20	Pillar pocket, raw right		0.12 kg	6.071.146.99

*Subject to change | Date: July 2016

FLATBED SUPERSTRUCTURE

LONG-RANGE-BOLT FASTENER 712

- For drop-side vehicles
- Single lock; the locked position of the locking unit is held by an over-centre position and a button locking device
- Easy to install, easy to operate

Typical fields of application

- For 400 mm - 800 mm drop-sides
- Use the 710 or 712 lock system, depending on the installation situation

Technology

- Good closing behaviour thanks to interaction between pocket and bolt
- Automatic adjustment
- The hand lever folds in when the drop-side is lowered
- Unlocking and locking are both possible under cargo pressure
- Cargo pressure detection is effected by traction between bolt and pillar pocket
- Above 600 mm profile height the hand lever is covered by the tarpaulin
- A special profile variant with lateral inspection openings for customs-specified drop-side locking is available as an option for the 712 fastener

Versions

Lock mechanism hot-dip galvanised to FHS-TL 9.01

Aluminium profiles: available in various surface finishes, e.g. raw or anodised

Accessories

710.20 Pillar pocket, raw, for welding

SolidMaster pillar pocket for bolting



712

*Subject to change | Date: July 2016

LONG-RANGE-BOLT FASTENER 712

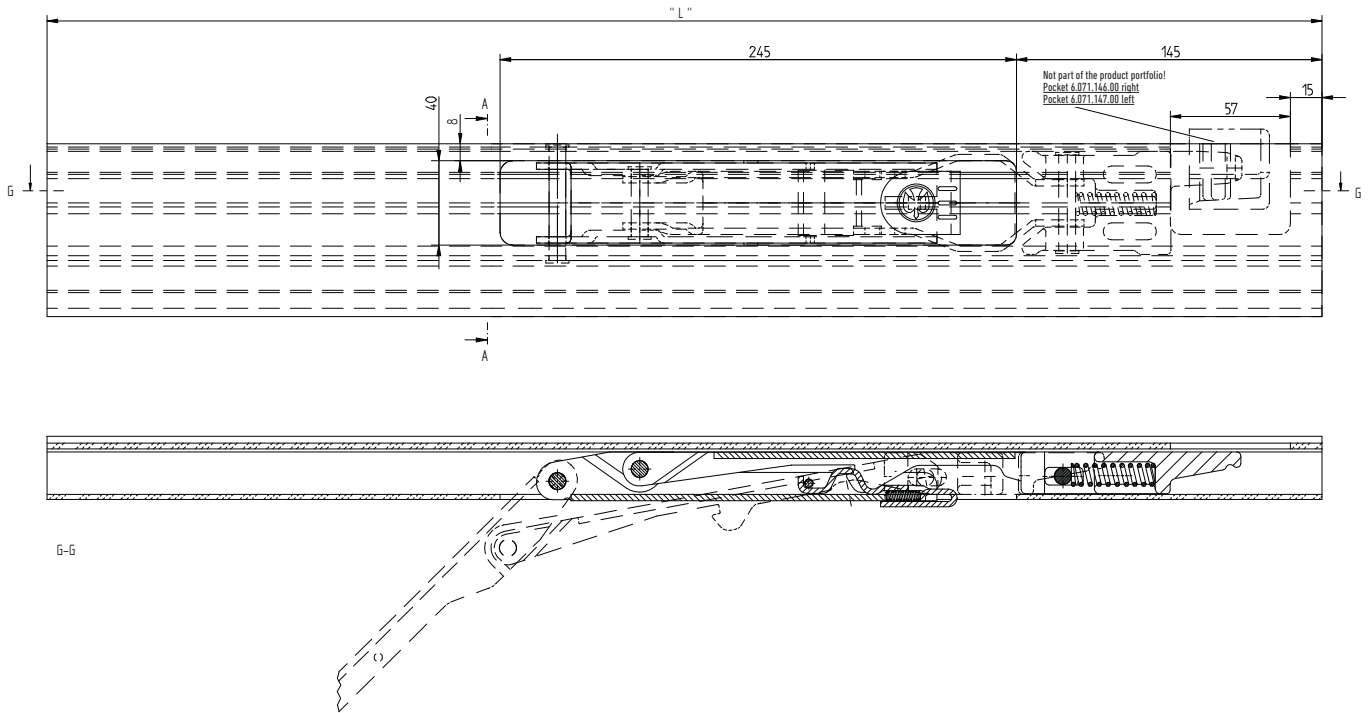

Type	Description	Length	Weight	Order no.
712.4	Lock in profile left, profile raw	415 mm	1.37 kg	6.020.804.95
712.4	Lock in profile right, profile raw	415 mm	1.37 kg	6.020.803.95
712.5	Lock in profile left, profile raw	515 mm	1.52 kg	6.020.808.95
712.5	Lock in profile right, profile raw	515 mm	1.52 kg	6.020.807.95
712.6	Lock in profile left, profile raw	615 mm	1.67 kg	6.020.800.95
712.6	Lock in profile right, profile raw	615 mm	1.67 kg	6.020.799.95
712.8	Lock in profile left, profile raw	815 mm	1.96 kg	6.020.812.95
712.8	Lock in profile right, profile raw	815 mm	1.96 kg	6.020.811.95

*Subject to change | Date: July 2016

LONG-RANGE-DOUBLE-BOLT FASTENER 715

For building material vehicles. Double lock; the locked position of the locking unit is held by an over-dead-centre position and a button locking device. Easy to install, easy to operate.

Typical fields of application

- Building material vehicles with a drop-side height of 800 mm or 1000 mm
- The 715 fastener can be combined with the HESTAL SolidMaster 801 hinged pillar system

Technology

- Good closing behaviour thanks to interaction between pocket and bolt
- Automatic adjustment
- An additional plastic strip on the enclosure profile reduces wear
- The hand lever folds in when the drop-side is lowered

Versions

Lock mechanism electrogalvanised to FHS-TL 9.01

Aluminium profile: raw or anodised

Accessories

801 KTL pillar pocket, for bolting

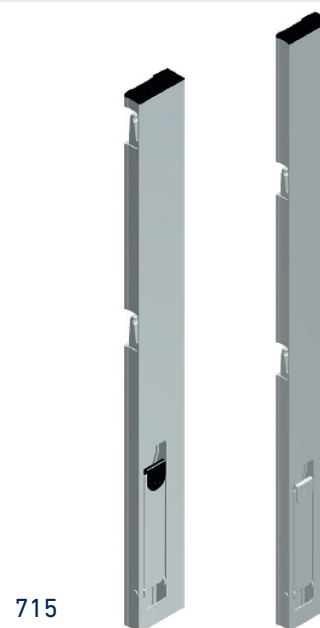

715

Type	Description	Length	Weight	Order no.
715.8	Lock in profile left, profile raw	815 mm	2.59 kg	6.020.858.00
715.8	Lock in profile right, profile raw	815 mm	2.59 kg	6.020.859.00
715.10	Lock in profile left, profile raw	1015 mm	2.88 kg	6.020.862.00
715.10	Lock in profile right, profile raw	1015 mm	2.88 kg	6.020.863.00

*Subject to change | Date: July 2016

LONG-RANGE-DOUBLE-BOLT FASTENER 715

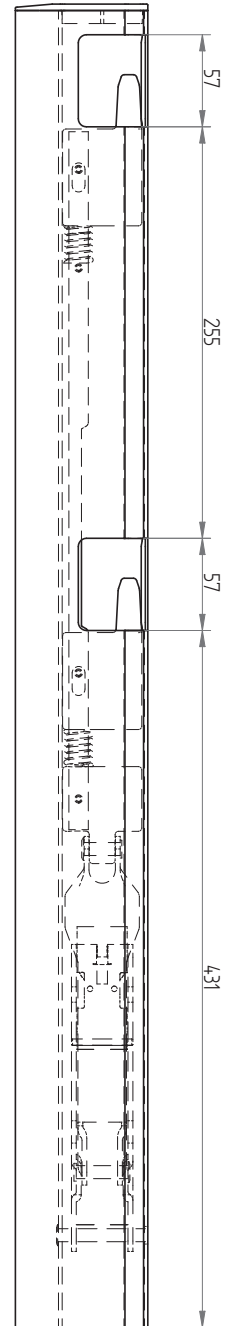
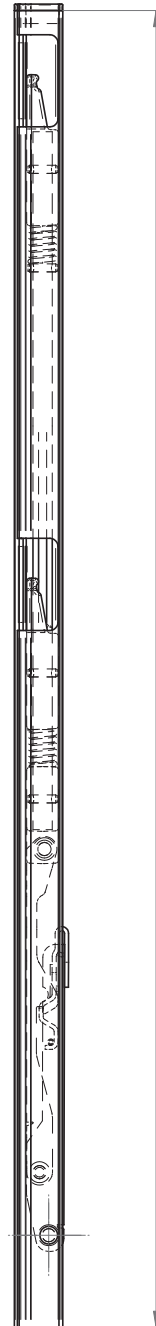
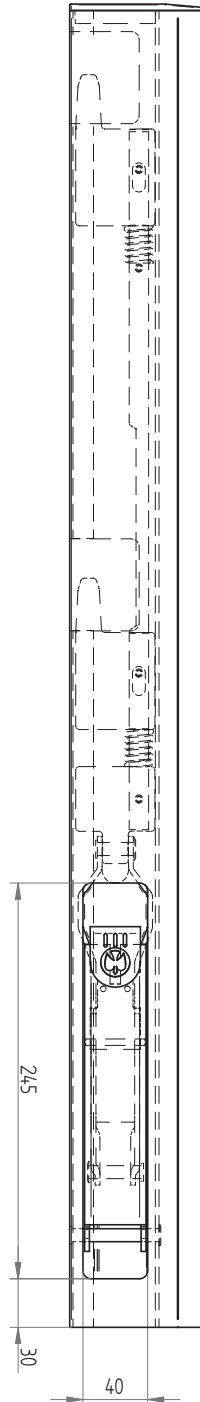
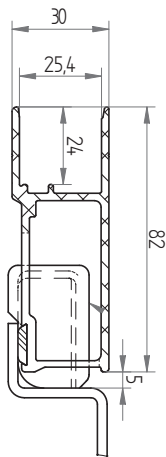

*Subject to change | Date: July 2016

SMALL FLATBED CORNER SYSTEM 720

A complete corner system for small light and medium-heavy flatbed superstructures, up to 500 mm drop-side height. Pillar-free corner connection, without further components.

Technology

- Easy operation and optimised safety
- Hand lever opening by 180 degrees
- The lock lies flush against the drop-side
- Double security with form and frictional locking
- Tested in accordance with the occupational health & safety regulations



720

Versions

Aluminium profiles: anodised FHS-TL 9.17
 Hand lever assembly: Powder coating, black
 Lock mechanism: yellow chromated and sealed,
 DIN 50021-SS480 h to FHS-TL 9.30
 (Further versions possible on request)

Type	Description	Length	Weight (kg)	Order no.
720.4	Small flatbed corner system left	400 mm	1.78 kg	6.021.673.00
720.4	Small flatbed corner system right	400 mm	1.78 kg	6.021.672.00
720.4	Small flatbed corner system left	415 mm	1.82 kg	6.020.921.00
720.4	Small flatbed corner system right	415 mm	1.82 kg	6.020.920.00
720.5	Small flatbed corner system left	500 mm	2.03 kg	6.021.675.00
720.5	Small flatbed corner system right	500 mm	2.03 kg	6.021.674.00
720.5	Small flatbed corner system left	515 mm	2.07 kg	6.020.923.00
720.5	Small flatbed corner system right	515 mm	2.07 kg	6.020.922.00
720.6	Small flatbed corner system left	600 mm	2.28 kg	6.021.677.00
720.6	Small flatbed corner system right	600 mm	2.28 kg	6.021.676.00
720.6	Small flatbed corner system left	615 mm	2.32 kg	6.020.925.00
720.6	Small flatbed corner system right	615 mm	2.32 kg	6.020.924.00

*Subject to change | Date: July 2016

SMALL FLATBED CORNER SYSTEM 720

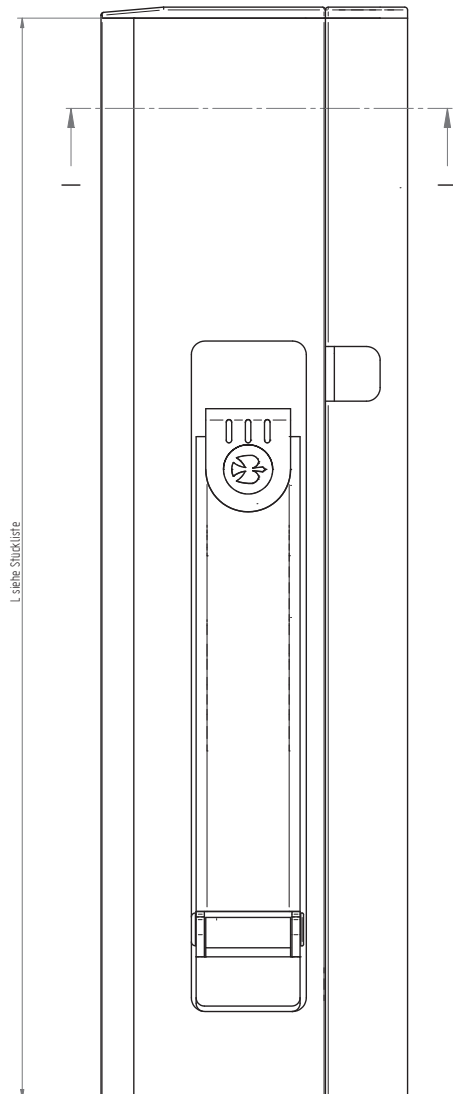

SECTION I-I

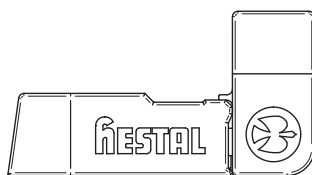
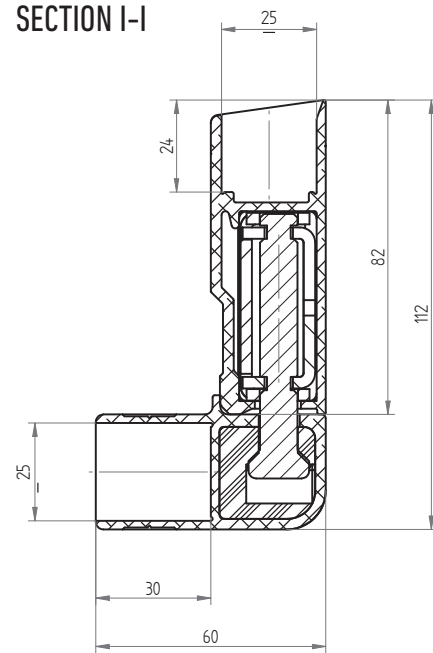

*Subject to change | Date: July 2016

LONG-THROW BUILT-IN BOLT TENSION LOCK 810

The fields of application are drop-sides with a height of 400 mm – 800 mm. The 810 fastener can be particularly well combined with the HESTAL SolidMaster hinged pillar system. It can be supplied in the desired lengths in a raw, anodised or powder-coated enclosure profile.

Technology

- Good closing behaviour is achieved by the interaction between pocket and bolt. The automatic adjustment of the drop-side is effected by a flexible compensation in the lock element / bolt so that the drop-side always fits free of play even under high loads.
- The 810 fastener is prevented from inadvertent opening by its over-dead-centre position and an additional button locking device.
- An extension unit in the lock (individually adapted to the respective nominal length) ensures that the hand lever in conjunction with the SolidMaster system is always in a uniform ergonomic operating position, except the 400 mm version. A rubber profile seal or polyamide strip can be inserted into the T groove in the enclosure profile. Use of the rubber profile seal ensures high resistance to splash water.
- When the drop-side is folded down, the hand lever drops down under its own weight and rests against the drop-side.

Versions

- Nominal lengths: 400 mm, 500 mm, 600 mm, 800 mm
- Enclosure profile: raw, anodised, powder-coated
- Lock elements: KTL coated
- PA strip or rubber profile seal



810

*Subject to change | Date: July 2016

LONG-RANGE-BOLT FASTENER 810

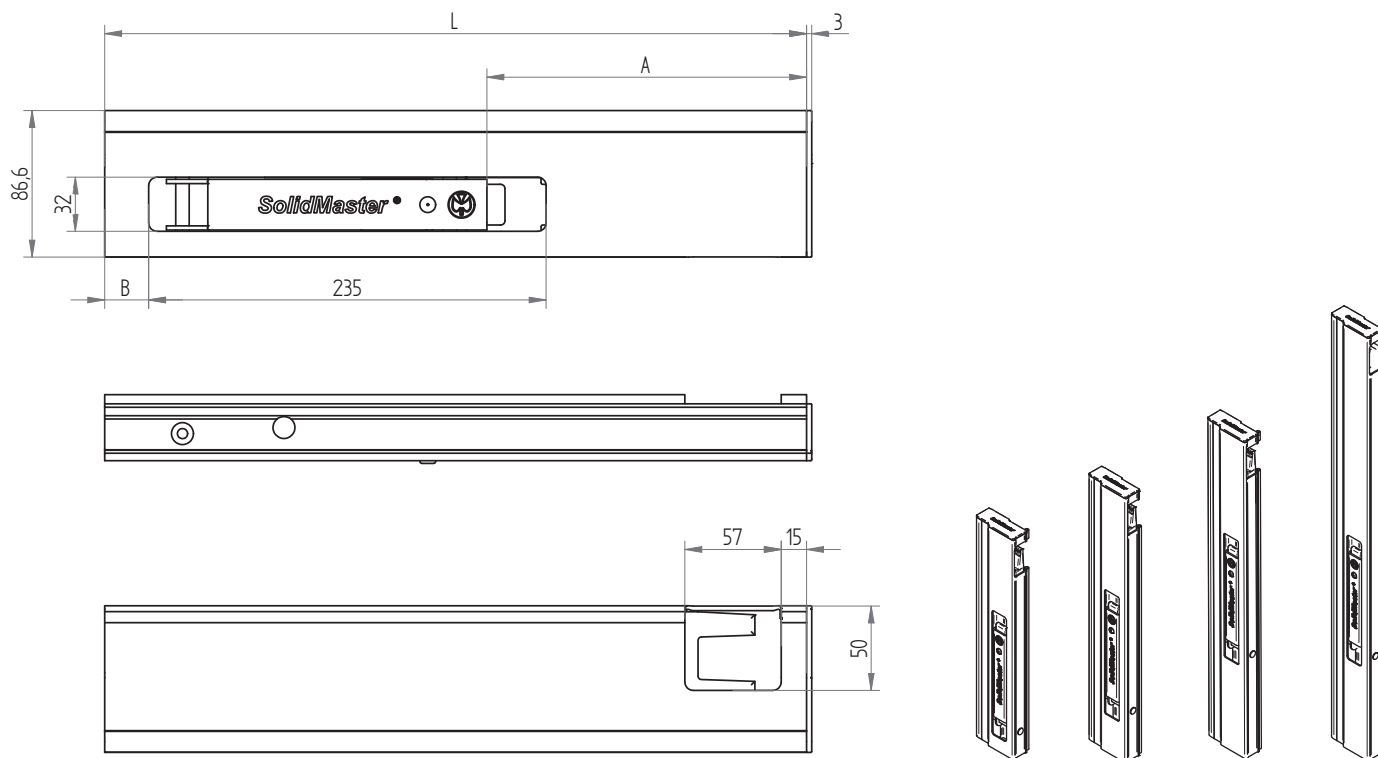

Type	Description	Length	Order no.
810.4	Lock in profile left smooth, profile raw	400 mm	6.021.680.00
810.4	Lock in profile right smooth, profile raw	400 mm	6.021.679.00
810.4	Lock in profile left with seal, profile raw	400 mm	6.021.686.00
810.4	Lock in profile right with seal, profile raw	400 mm	6.021.685.00
810.4	Lock in profile left with rain lug, profile raw	415 mm	6.021.631.00
810.4	Lock in profile right with rain lug, profile raw	415 mm	6.021.630.00
810.5	Lock in profile left smooth, profile raw	500 mm	6.021.692.00
810.5	Lock in profile right smooth, profile raw	500 mm	6.021.691.00
810.5	Lock in profile left with seal, profile raw	500 mm	6.021.698.00
810.5	Lock in profile right with seal, profile raw	500 mm	6.021.697.00
810.5	Lock in profile left with rain lug, profile raw	515 mm	6.021.704.00
810.5	Lock in profile right with rain lug, profile raw	515 mm	6.021.703.00
810.6	Lock in profile left smooth, profile raw	600 mm	6.021.710.00

*Subject to change | Date: July 2016

to be continued →

LONG-RANGE-BOLT FASTENER 810

Type	Description	Length	Order no.
810.6	Lock in profile right smooth, profile raw	600 mm	6.021.709.00
810.6	Lock in profile left with seal, profile raw	600 mm	6.021.716.00
810.6	Lock in profile right with seal, profile raw	600 mm	6.021.715.00
810.6	Lock in profile left with rain lug, profile raw	615 mm	6.021.633.00
810.6	Lock in profile right with rain lug, profile raw	615 mm	6.021.632.00
810.8	Lock in profile left smooth, profile raw	800 mm	6.021.722.00
810.8	Lock in profile right smooth, profile raw	800 mm	6.021.721.00
810.8	Lock in profile left with seal, profile raw	800 mm	6.021.728.00
810.8	Lock in profile right with seal, profile raw	800 mm	6.021.727.00
810.8	Lock in profile left with rain lug, profile raw	815 mm	6.021.635.00
810.8	Lock in profile right with rain lug, profile raw	815 mm	6.021.634.00

*Subject to change | Date: July 2016

LONG-RANGE-BOLT FASTENER 815

The fields of application are drop-sides with a height of 1000 mm. The 815 fastener can be particularly well combined with the HESTAL SolidMaster hinged pillar system. It can be supplied in the desired lengths in a raw, anodised or powder-coated enclosure profile.

Technology

- Good closing behaviour is achieved by the interaction between pocket and bolt. The automatic adjustment of the drop-side is effected by a flexible compensation in the lock element / bolt so that the drop-side always fits free of play even under high loads.
- The 815 fastener is prevented from inadvertent opening by its over-dead-centre position and an additional button locking device.
- An extension unit in the lock (individually adapted to the respective nominal length) ensures that the hand lever in conjunction with the SolidMaster system is always in a uniform ergonomic operating position. A rubber profile seal or polyamide strip can be inserted into the T groove in the enclosure profile. Use of the rubber profile seal ensures high resistance to splash water.
- When the drop-side is folded down, the hand lever drops down under its own weight and rests against the drop-side.

Versions

- Nominal lengths: 1000 mm
- Enclosure profile: Raw, anodised, powder-coated
- Lock elements: KTL coated
- PA strip or rubber profile seal



*Subject to change | Date: July 2016

LONG-RANGE-BOLT FASTENER 815

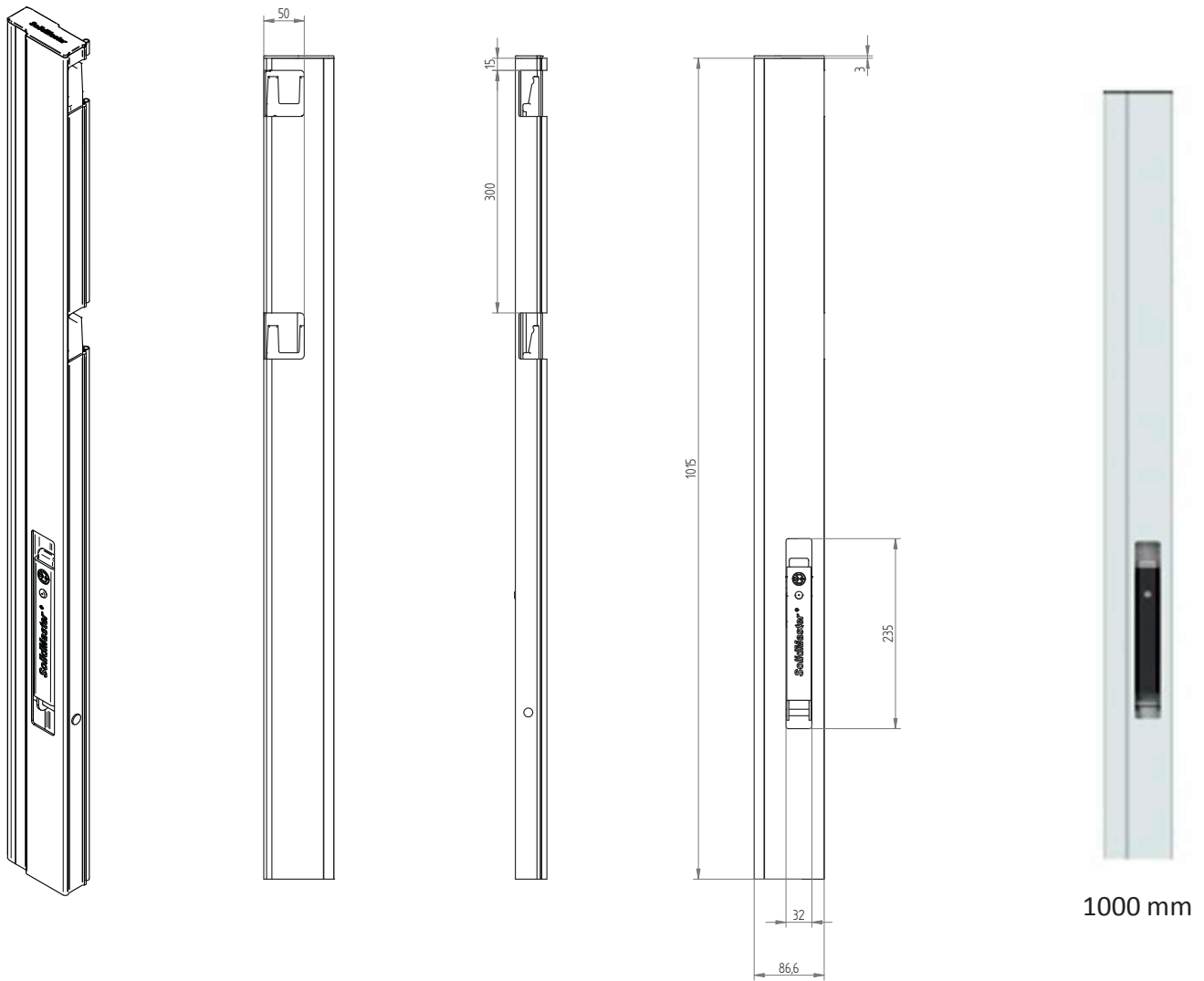

Type	Description	Length	Order no.
815.10	Built-in flat bolt tension lock, raw – right	1015 mm	6.021.636.00
815.10	Built-in flat bolt tension lock, raw – left	1015 mm	6.021.637.00

*Subject to change | Date: July 2016

FLAT-BOLT FASTENER 680

The 680 fastener is a custom lock whose lever is under the tarpaulin when in closed position. It moves easily and is characterised by its extremely flat design.

Typical fields of application

The 680 fastener has been specially designed for very low installation heights for vehicles with pillars. It is used with middle and corner pillars. The lock can also be installed in hasp profiles.

Technology

- The 680 fastener satisfies custom requirements as the horizontal lever is under the tarpaulin when in closed position. The lever is held in both end positions by a spring-loaded ball lock. Its ease of movement is provided by a plastic bearing at the pivot point of the lever. The handle has a height of 28 mm. The housing has a height of 20.5 mm. The 680 fastener requires an installation height of 20.5 mm.

Versions

Hot-dip galvanised to FHS-TL 9.01



Type	Description	Side	Install height	Weight	Order no.
680	Flat-bolt fastener, galvanised	Right	20.5 mm	129.5 kg	6.040.031.00
680	Flat-bolt fastener, galvanised	Left	20.5 mm	129.5 kg	6.040.032.00

*Subject to change | Date: July 2016

FLATBED SUPERSTRUCTURE

FLAT-BOLT FASTENER 682

The 682 fastener is a built-in lock for drop-sides. Thanks to its high-strength components, it is suitable for high loads with low wear.

Typical fields of application

The 682 fastener is designed for medium-heavy and heavy flatbed and folding wall superstructures. The fastener is locked by means of a slot in the pillar.

Technology

- To ensure sturdiness of the fastener, all lock parts are made of high-strength materials
- The lock is designed with a toggle-lever system
- A locking spring of stainless steel locks the hand lever
- The stroke is 24 mm

Versions

Hot-dip galvanised to FHS-TL 9.01

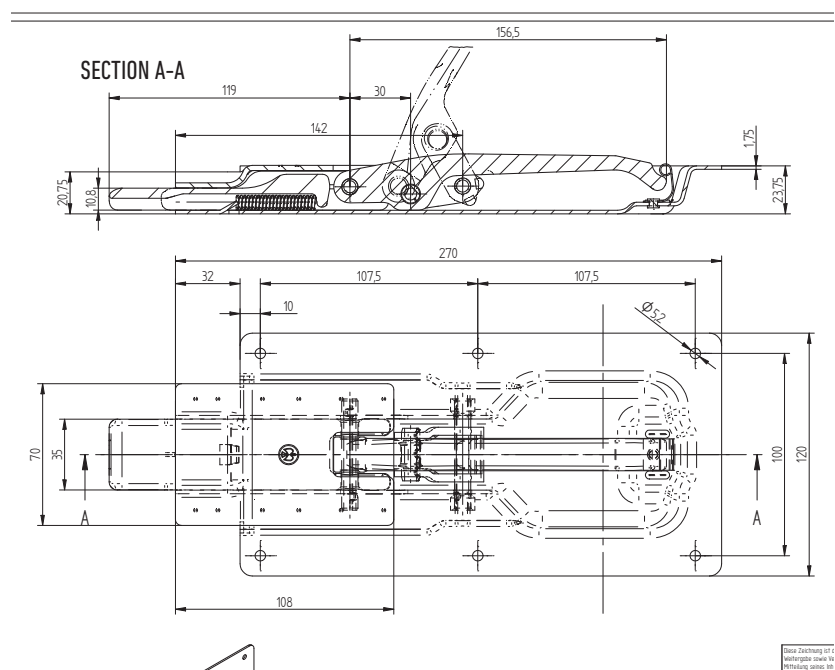
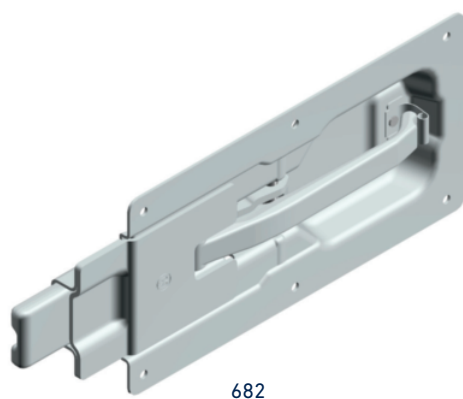

Type	Description	Weight	Order no.
682	Flat-bolt fastener, galvanised	1.44 kg	6.060.013.00

*Subject to change | Date: July 2016

FLATBED SUPERSTRUCTURE

FLAT-BOLT FASTENER 686S, 686SN, 686S10

- The 686S, 686SN, 686S10 are build-in fasteners for drop-sides
- Systematic locking during closing
- Lock system with cargo pressure detection
- 686S, 686SN with plastic locking button integrated into the recess
- 686S10 with steel locking button integrated into the handle

Typical fields of application

- Medium-heavy flatbed superstructures
- Used for middle and corner pillars
- With drop-side holders for pillar-free vehicle superstructures
- Use only with offset 25 mm drop-side enclosure profiles

Technology

- Has a tensile strength of 2.5 t
- In the event of cargo pressure, the lock automatically secures the drop-side
- The system engages in an arresting position when opened under cargo pressure
- The lock has a flexible compensation for driving mode to prevent an unintentional opening
- Contains two independent locking devices
- Satisfies the regulations of the German employers' liability insurance association

Versions

Hot-dip galvanised to FHS-TL 9.01

Accessories

6817 Pillar pocket, raw

6818 Corner pillar pocket, raw

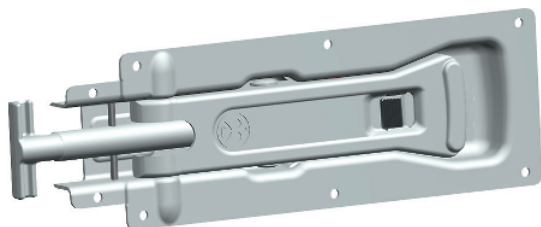

686SN

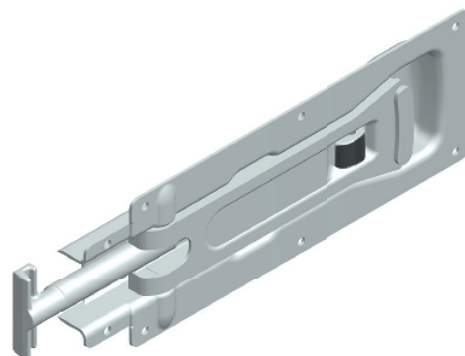

686S



686S10

*Subject to change | Date: July 2016

FLATBED SUPERSTRUCTURE

FLAT-BOLT FASTENER 686S, 686SN, 686S10

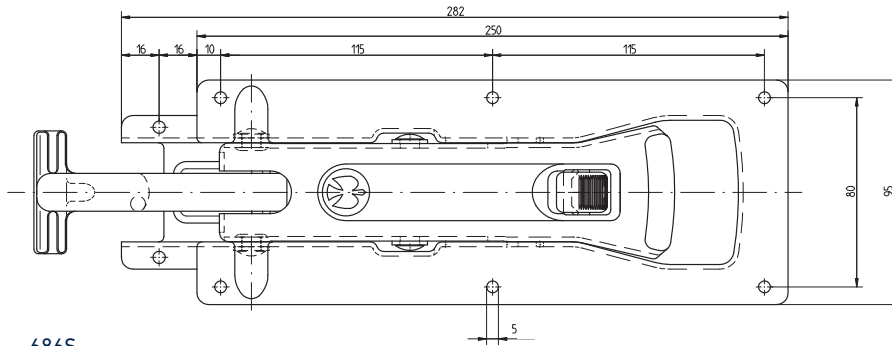

686S

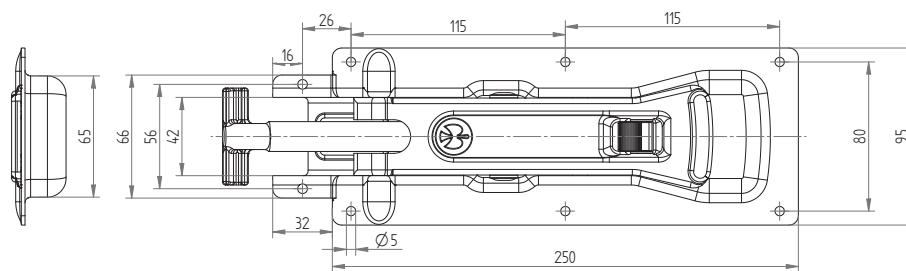

686S10

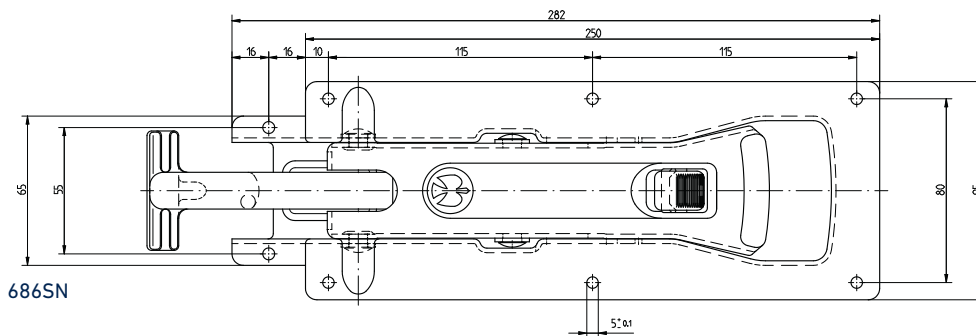

686SN

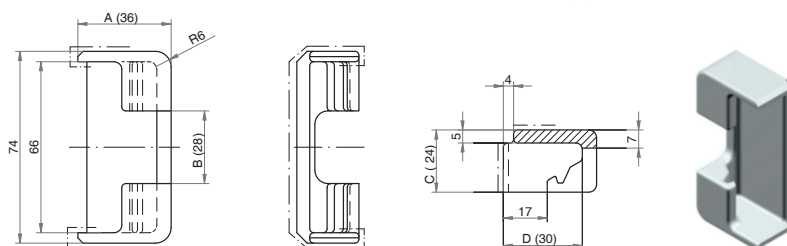

Type	Description	Weight	Order no.
686S	Lock, electrogalvanised with cargo pressure safeguard	1.21 kg	6.060.261.00
686S10	Lock assembly, complete	1.22 kg	6.060.320.00
686SN	Lock, electrogalvanised with cargo pressure safeguard and lift-out device	1.21 kg	6.060.250.00
6817	Pillar pocket, raw; installation on the pillar stop by welding	0.21 kg	6.071.129.99
6818	Corner pillar pocket, raw; installation on a corner pillar by welding	0.20 kg	6.071.137.99

*Subject to change | Date: July 2016

TENSION-BOLT FASTENER 681S/1, 681SL, 681S10

The 681S fastener is based on the proven built-in tension-bolt lock principle. The 681 has a semi-automatic push-button locking device. The fasteners have a cargo pressure detection.

Typical fields of application

- Medium-heavy and heavy flatbed superstructures
- Aluminium or steel drop-sides (wall thickness 25 mm)
- Use only with offset 25 mm drop-side enclosure profiles for hinged pillars installed on the outer frame
- Pillar pockets are bolted or welded to the side of the hinged pillar

Technology

- Has a tensile strength of 4.5 t
- The system engages in an arresting position when opened under cargo pressure
- The flexible compensation of the lock prevents unintentional opening while driving
- Contains two independant locking systems
- Satisfies the regulations of the German employers' liability insurance association

Versions

Hot-dip galvanised to FHS-TL 9.01

Attachment examples

- Can be ordered specially for drop-side bezels

Accessories

- 6817 Pillar pocket, non-galvanised
- 6818 Corner pillar pocket, non-galvanised
- 801 Pillar pocket, KTL coated FHS TL 9.13
- 801H Corner pillar pocket, KTL coated FHS TL 9.13

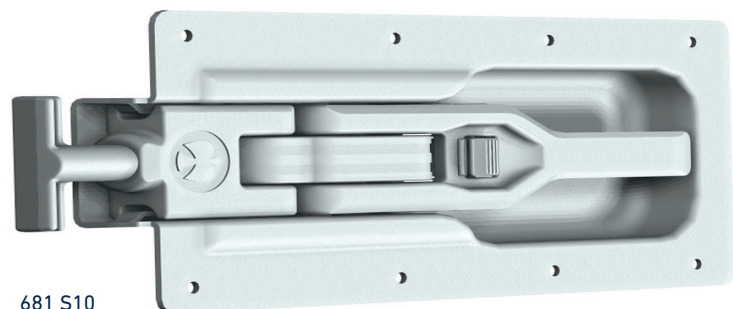

*Subject to change | Date: July 2016

TENSION-BOLT FASTENER 681S/1, 681SL, 681S10

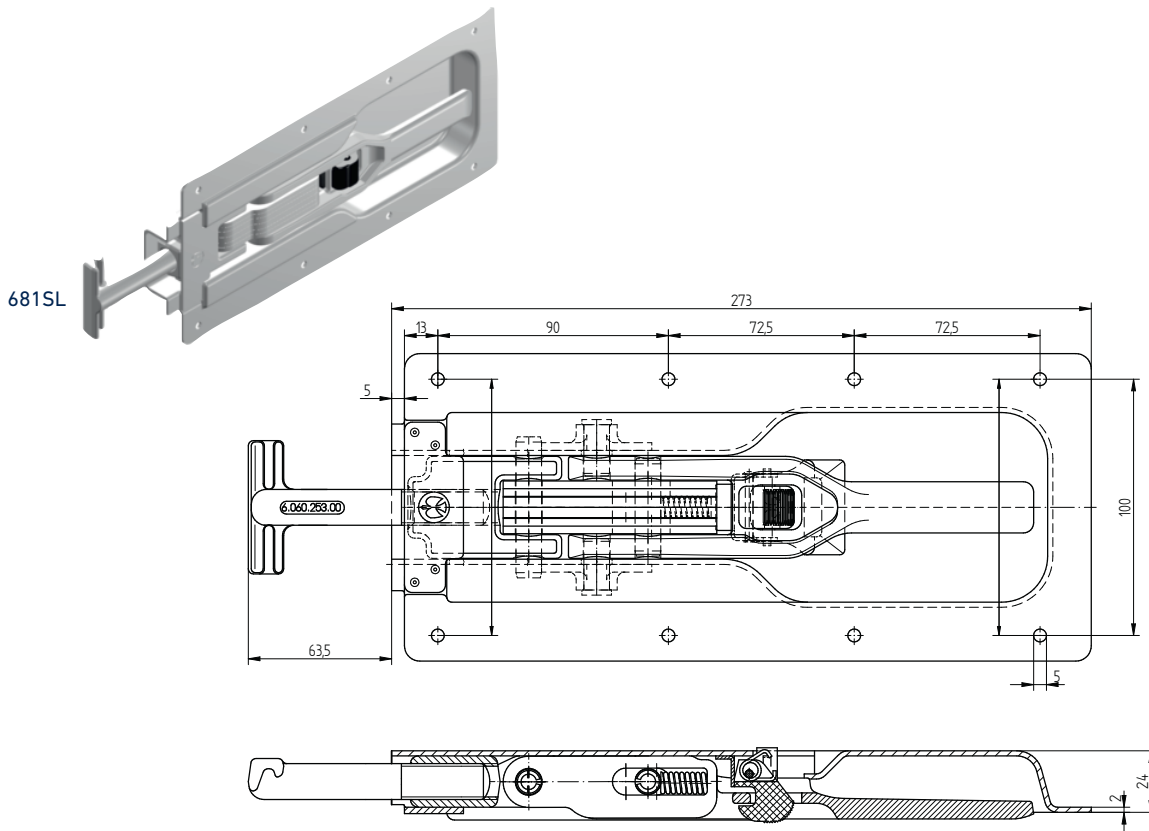
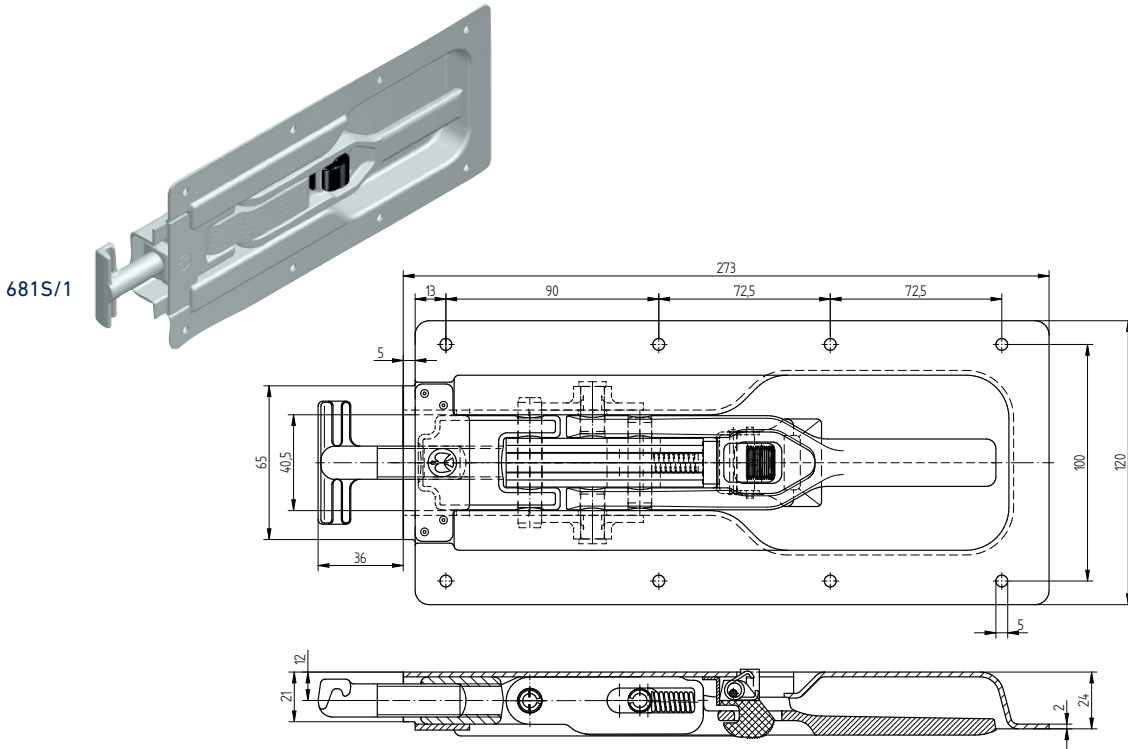

*Subject to change | Date: July 2016

TENSION-BOLT FASTENER 681S/1, 681SL, 681S10

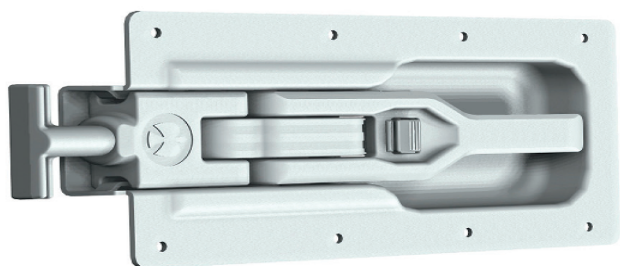

681S10

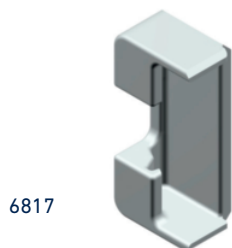
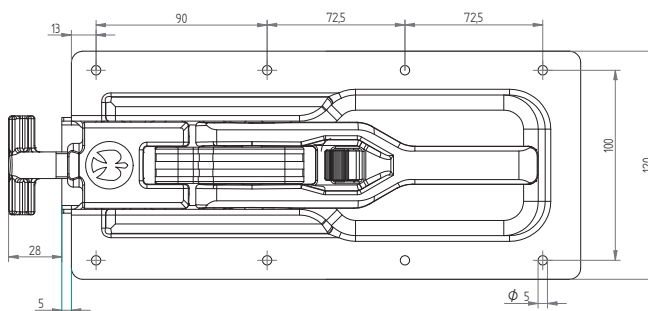

6817

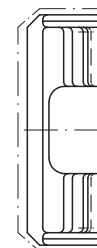
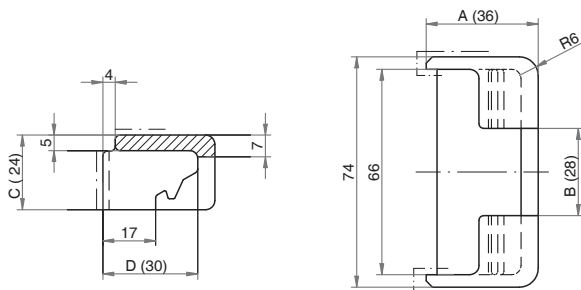

Type	Description	Weight	Order no.
681S/1	Lock	1.57 kg	6.060.258.00
681S/1	Fastener, electrogalvanised in conjunction with pillar pocket 6817 or corner pillar pocket 6818	1.57 kg	6.060.233.00
681S/1	Fastener, without tightening bolt	1.57 kg	6.060.233.00
681SL	Fastener, electrogalvanised	1.57 kg	6.060.257.00
681SL	Tightening bolt	0.15 kg	6.060.253.00
6817	Pillar pocket, raw, installation on the pillar stop for welding	0.21 kg	6.071.129.00
6818	Corner pillar pocket, raw; installation on the pillar stop by welding or riveting	0.20 kg	6.071.137.00
		0.36 kg	6.071.154.00
6915	Cylinder lock, for use only in 681S1	0.07 kg	6.101.104.00
681S10	Fastener	1.516 kg	6.060.311.00
681S10	T-piece tightening bolt	0.107 kg	6.060.234.00
681SL10	Fastener	1.516 kg	6.060.315.00
681SL10	Tightening bolt	0.105 kg	6.060.253.00

*Subject to change | Date: July 2016

OVERVIEW

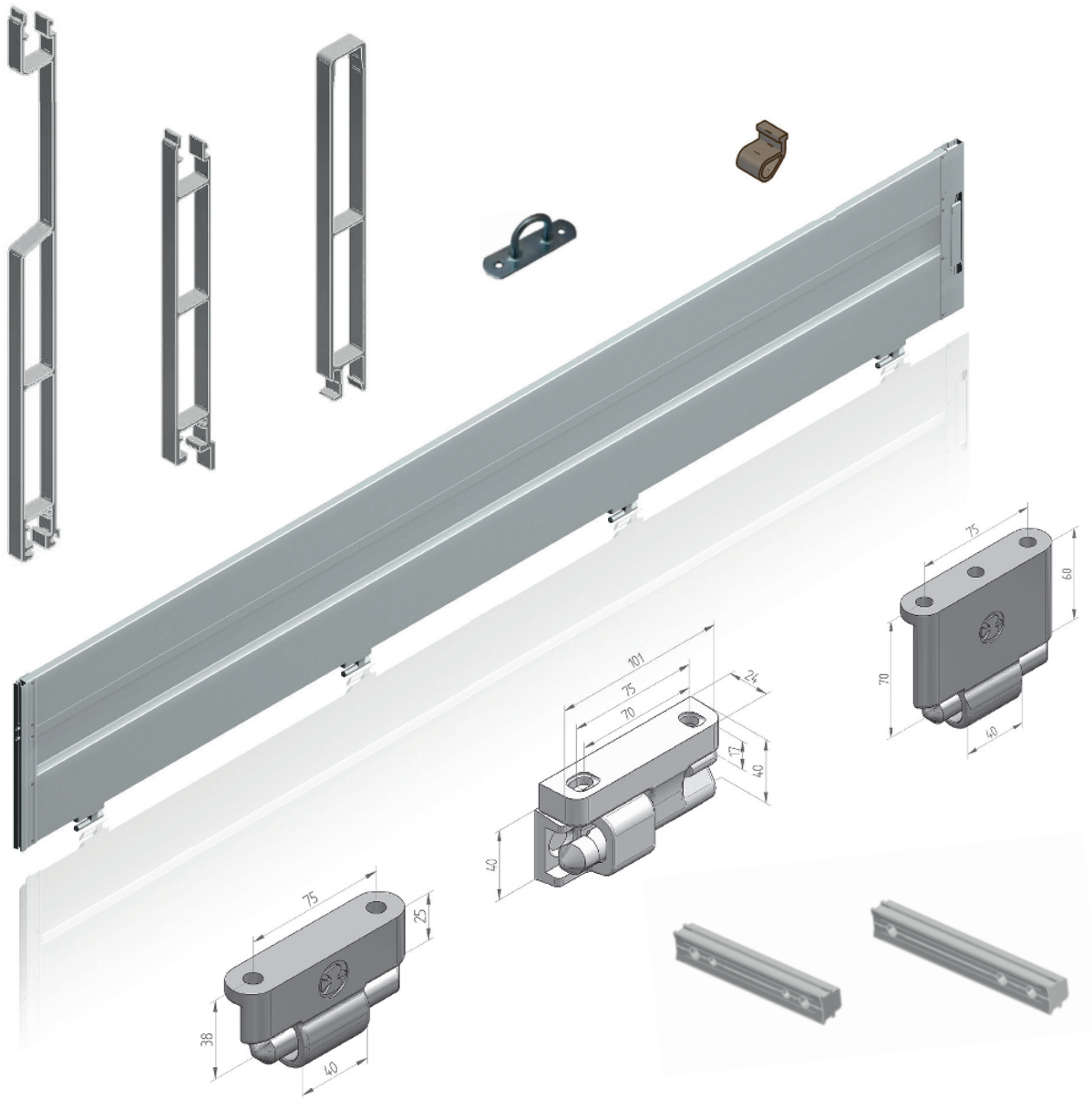

- Drop-side hinges 654N, 655N, 656N, 657
- HESTAL Snap 25 profiles
- HESTAL Snap 25 accessories

DROP-SIDE HINGE 654N

654N is a proven hinge for aluminium drop-sides (25 mm or 30 mm thick) satisfying customs requirements for medium-heavy and heavy flatbed superstructures.

Technology

- Positive-fit locking design principle prevents accidental opening of the drop-side
- The 654N hinge consists of bearing housing 6540N (which can be bolted or welded to the vehicle frame) and hinge bolt 6541N (is fastened to the drop-side)
- The hinge bolts can alternatively be ordered with M12 tie rod bore (which is special version available at additional charge)

Versions

Hinge bolt, electrogalvanised to FHS-TL 9.01

Bearing housing, raw or electrogalvanised to FHS-TL 9.01

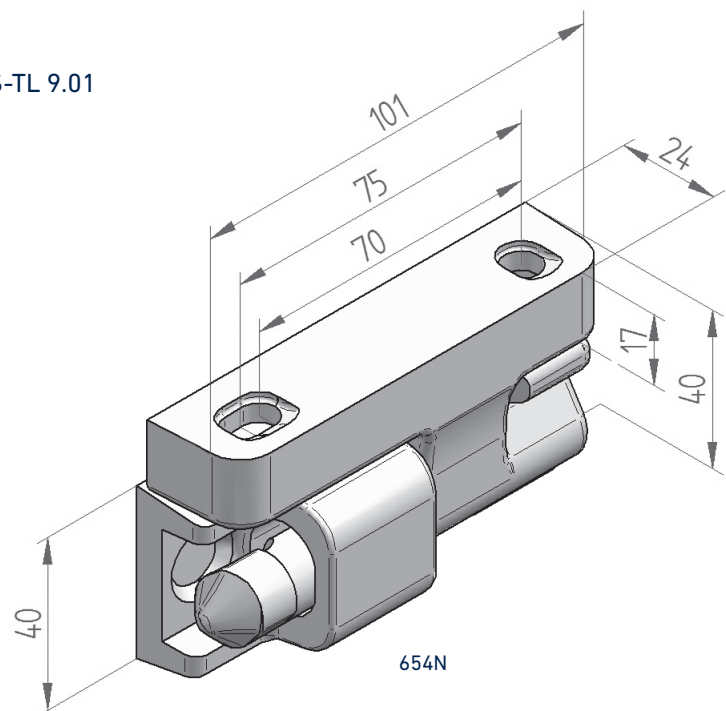

Type	Description	Weight	Order no.
6540N	Hinge bearing, raw, non-drilled	0.30 kg	6.510.409.99
65400N	Hinge bearing, galvanised	0.30 kg	6.510.418.99
6541N	Hinge bolt, galvanised	0.34 kg	6.510.410.99
6541N	Bolt with tie rod bore, galvanised	0.33 kg	6.510.419.99

*Subject to change | Date: July 2016

ALUMINIUM DROP-SIDE

DROP-SIDE HINGE 655N, 656N

- 655N and 656N are proven hinges for aluminium drop-sides (25 mm thick) satisfying customs requirements for medium-heavy and heavy flatbed superstructures (hinge 656N and for swap bodies)
- The large pivot point distance of hinge 656N allows easy folding down of the drop-sides beyond the lateral extension protector

Technology

- Consists of non-galvanised welding bolt 6550N and galvanised pivot bearing 6552N
- The bolt is welded to the vehicle frame
- Pivot bearing is fastened to the drop-side
- Pivot bearing can alternatively be ordered with M12 tie rod bore (at additional charge)

Versions

Pivot bearing, electrogalvanised to FHS-TL 9.01

Welding bolt, raw or electrogalvanised to FHS-TL 9.01

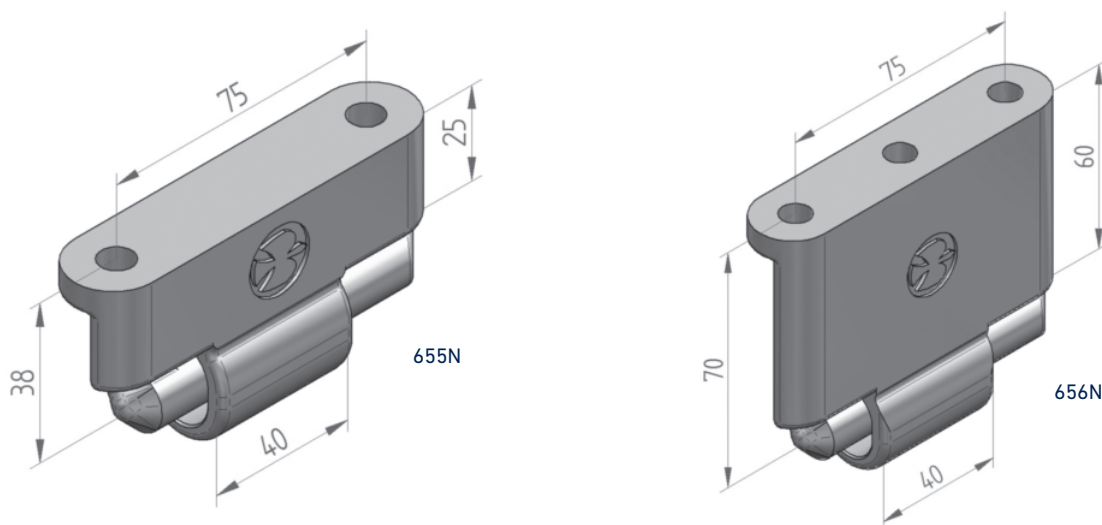

Type	Description	Weight	Order no.
6550N	Bolt right, raw	0.25 kg	6.511.355.99
6550N	Bolt left, raw	0.25 kg	6.511.356.99
6552N	Pivot bearing, galvanised	0.36 kg	6.510.354.99
6552N M12	Bearing with tie rod bore, galvanised	0.35 kg	6.510.363.00
6561N M12	Bearing with tie rod bore, galvanised	0.49 kg	6.510.430.99

*Subject to change | Date: July 2016

DROP-SIDE HINGE 657

- The drop-side hinge satisfying customs requirements is suitable for light flatbed superstructures and car trailers of all kinds
- For 25 mm drop-sides of steel and aluminium
- For outboard and inboard drop-sides
- Thanks to the compact design, the hinge 657 can be used on narrow outer frames (bolt-on, weld-on)

Advantages/benefits

- Positive-fit locking design principle satisfies customs requirements and prevents accidental opening of the drop-side
- The individual components can be combined and allow a wide variety of mounting variations
- Drop-side hinge 657/2 has a pivot point distance from the drop-side profile of 32 mm, hinge 657/5 a pivot point distance of 38 mm

Versions

Hinge bolt and bearing housing, electrogalvanised to FHS-TL 9.01 (further surfaces, such as hot-dip galvanised to FHS-TL 9.22 available on special order)

Bearing housing 6576 additionally KTL black coated to FHS-TL 9.13

Type	Description	Weight	Order no.
6570	Bearing housing, raw	0.13 kg	6.510.470.99
6572	Hinge bolt, galvanised	0.18 kg	6.510.469.99
6575	Hinge bolt, hot-dip galvanised	0.20 kg	6.510.598.99
6576	Bearing housing, KTL coated	0.13 kg	6.510.595.97
6576	Bearing housing, galvanised	0.13 kg	6.510.595.98
65700	Bearing housing, galvanised	0.11 kg	6.510.481.99
6572	Hinge bolt, raw	0.18 kg	6.510.469.98
65700	Bearing house, drilled	0.11 kg	6.510.481.98
65700	Bearing housing, galvanised	0.12 kg	6.510.533.99
6575	Hinge bolt, KTL coated	0.2 kg	6.510.598.97

*Subject to change | Date: July 2016

HESTAL SNAP 25

Field of application

For commercial vehicles up to 15 t gross vehicle weight in combination with an aluminium flatbed superstructure.

Technology

- Product reliability
 - Dekra-certified up to a payload of 10,7 t
 - Aluminium flatbed body in conjunction with certified body to DIN EN 12642 Code XL Annex A
- Product variety / high degree of flexibility
 - Drop-side height (400 mm, 500 mm, 600 mm, 800 mm, 1000 mm)
- Pillar variants (801 and 802)
 - Fastener variants (681S10, 710, 715, 720 ,810)
 - Hinge variants (654N, 655N, 657)
 - Hasp profile
 - Folding step
 - Surface finish in raw, anodised, powder primed and powder coated



*Subject to change | Date: July 2016

HESTAL SNAP 25 – UPPER END PROFILES

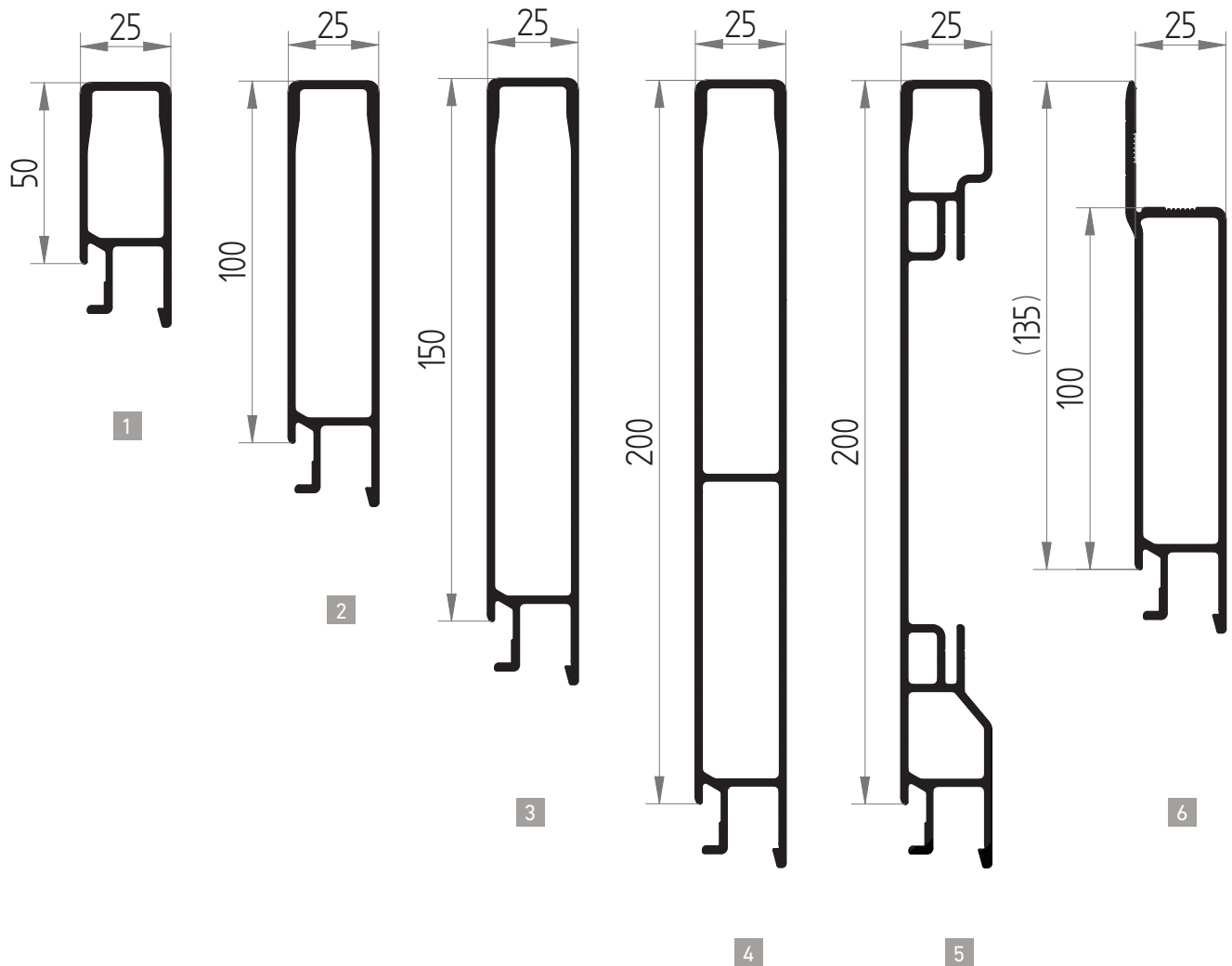

Pos.	Description	Weight	Order no.
1	Upper end profile 50 mm	1.050 kg/m	6.600.001.13
2	Upper end profile 100 mm	1.548 kg/m	6.600.001.14
3	Upper end profile 150 mm	2.046 kg/m	6.600.001.15
4	Upper end profile 200 mm	2.654 kg/m	6.600.001.16
5	Upper end profile 200 mm for lashing rail	2.519 kg/m	6.600.001.40
6	Adapter profile 100 mm for sandwich bulkhead	1.777 kg/m	6.600.001.36

*Subject to change | Date: July 2016

HESTAL SNAP 25 – MIDDLE PROFILES

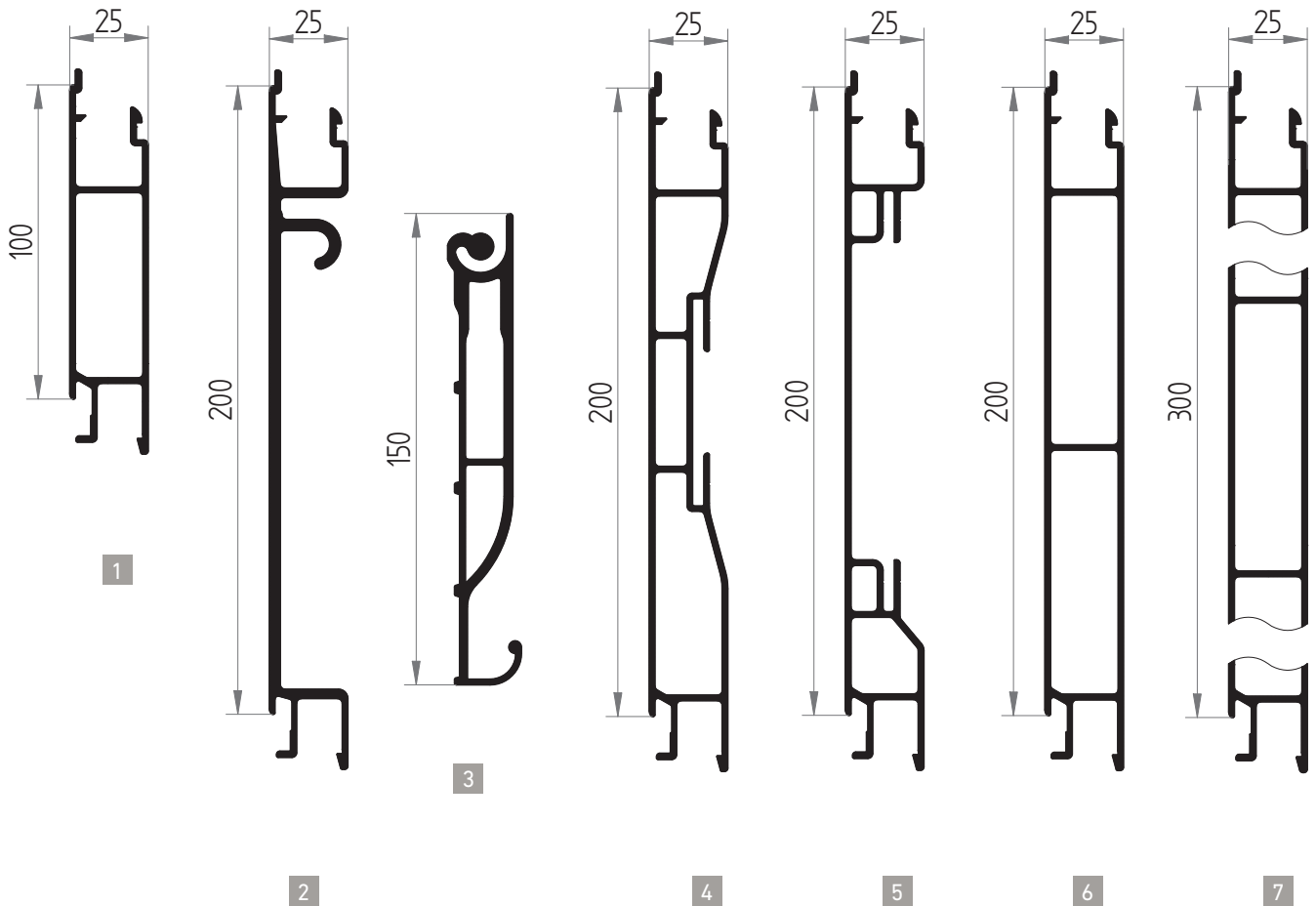

Pos.	Description	Weight	Order no.
1	Middle profile 100 mm	1.525 kg/m	6.600.001.06
2	Middle profile 200 mm, support profile for folding step	2.996 kg/m	6.600.001.11
3	Folding step	2.570 kg/m	6.600.001.12
4	Middle profile 200 mm, for Airline flange rail	2.878 kg/m	6.600.001.38
5	Middle profile 200 mm, for lashing rail	2.377 kg/m	6.600.001.39
6	Middle profile 200 mm	2.625 kg/m	6.600.001.08
7	Middle profile 300 mm	3.743 kg/m	6.600.001.24

*Subject to change | Date: July 2016

HESTAL SNAP 25 – MIDDLE PROFILES FOR CURTAIN CLAMPS

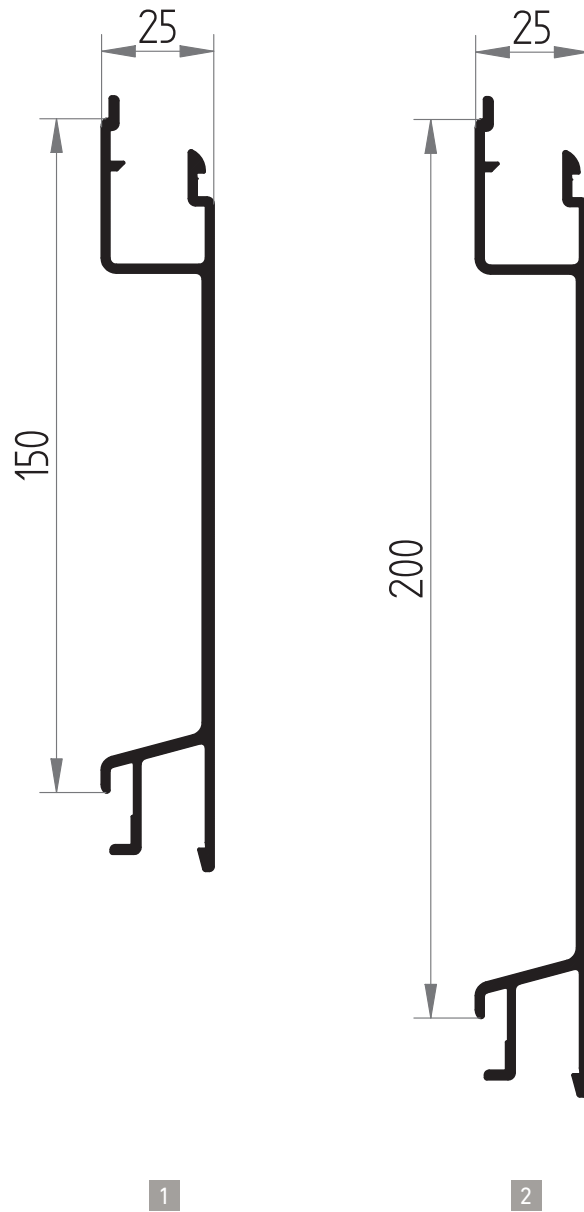

Pos.	Description	Weight	Order no.
1	Middle profile 150 mm, for curtain clamps	1.713 kg/m	6.600.001.09
2	Middle profile 200 mm, for curtain clamps	2.071 kg/m	6.600.001.10

*Subject to change | Date: July 2016

HESTAL SNAP 25 – LOWER END PROFILES

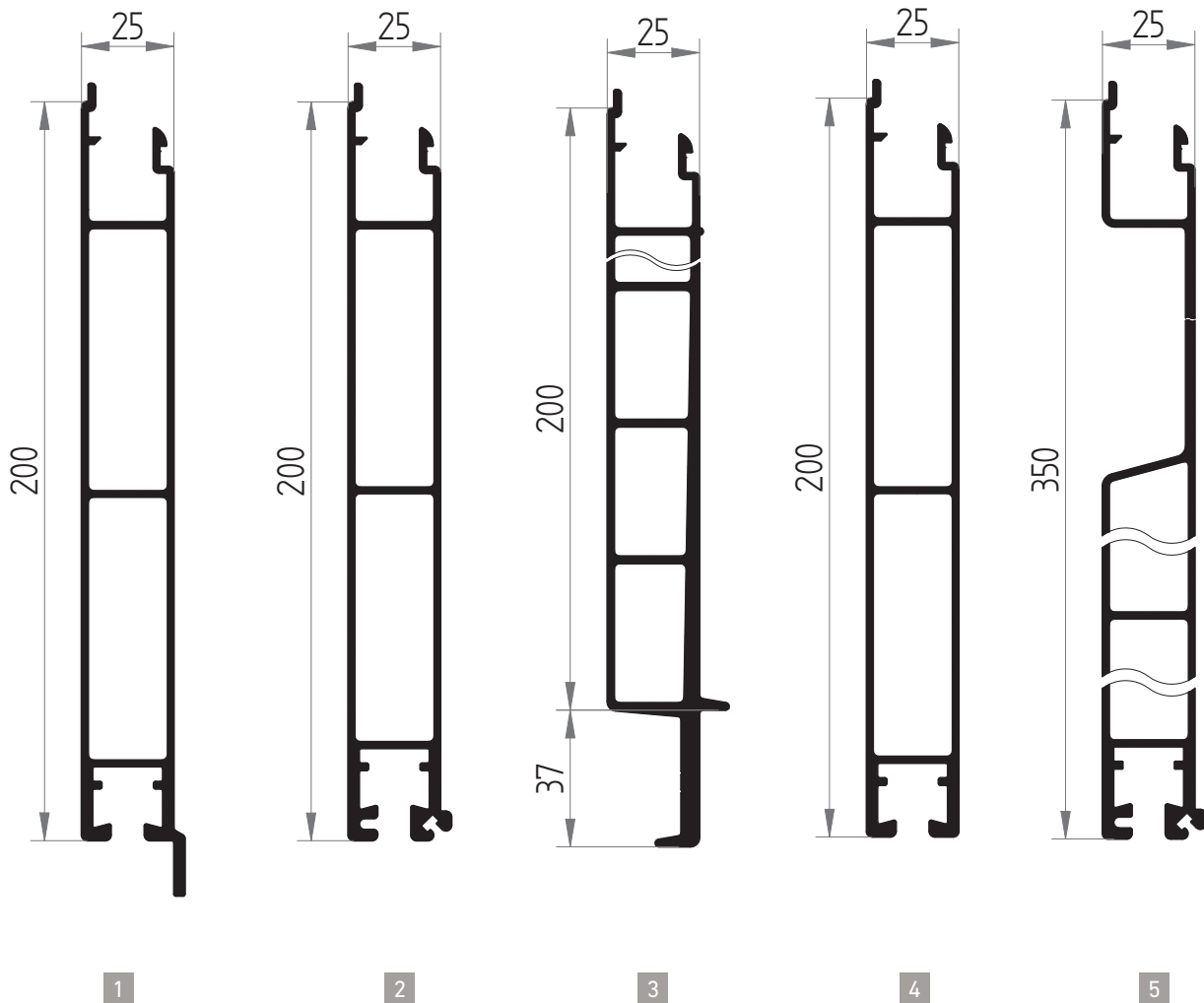

Pos.	Description	Weight	Order no.
1	Lower end profile 200 mm, with rain lug	2.816 kg/m	6.600.001.03
2	Lower end profile 200 mm, for seal	2.791 kg/m	6.600.001.05
3	Lower end profile 200 mm, for additional bulkhead	3.977 kg/m	6.600.001.35
4	Lower end profile 200 mm, smooth bottom	2.544 kg/m	6.600.001.37
5	Lower end profile 350 mm, for curtain clamps for seal	4.058 kg/m	6.600.001.27

*Subject to change | Date: July 2016

HESTAL SNAP 25 – BEZEL PROFILES

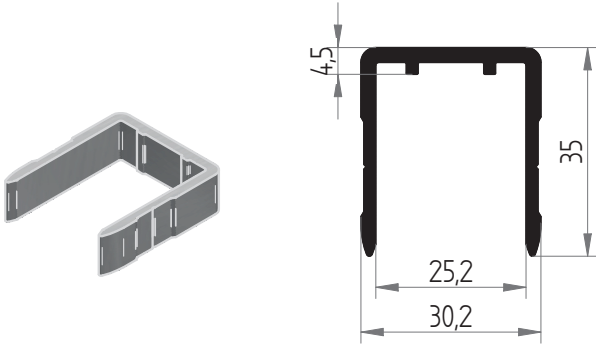
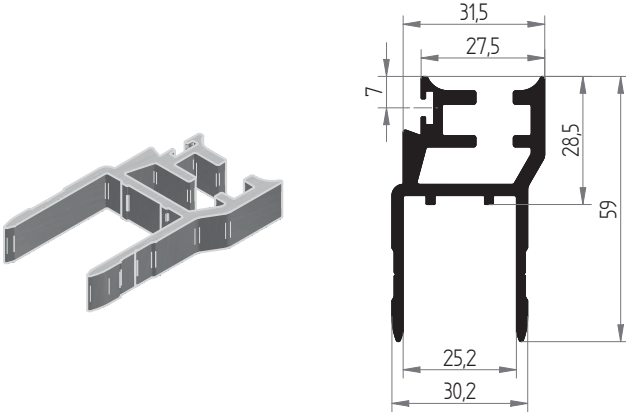
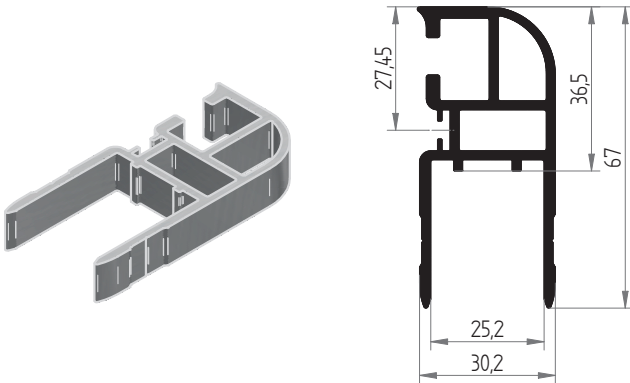
Figure	Weight	Order no.
	0.585 kg/m	6.600.001.17
	1.292 kg/m	6.600.001.18
	1.336 kg/m	6.600.001.19

*Subject to change | Date: July 2016

HESTAL SNAP 25 – BEZEL PROFILES

Figure	Weight	Order no.
	1.219 kg/m	6.600.001.20
	1.177 kg/m	6.600.001.22
	1.127 kg/m	6.600.001.41

*Subject to change | Date: July 2016

HESTAL SNAP 25 – ACCESSORIES

Figure	Description	Weight	Order no.
	Sliding stone M6/M8 for installation of drop-side hinges	0.051 kg/m	6.600.001.28
	Sliding stone M8 for installation of drop-side hinges	0.064 kg	6.600.001.30
	Seal profile for lower end profiles	0.064 kg	6.600.001.31
	Seal profile for side enclosures and rear enclosures 6.600.001.18 + 19	0.030 kg	6.600.001.45

*Subject to change | Date: July 2016

OVERVIEW



LockMaster 891.16

Hinge 895

- **Surface-mounted lock – LockMaster 890**
- **Built-in lock – LockMaster 891**
- **Surface-mounted lock – LockMaster NSB**
- **Surface-mounted lock – LockMaster NSE**
- **Box body hinge – HingeMaster 895**

BOX VAN LOCKS AND HINGES

Field of application

HESTAL offers a complete spectrum of lock variants that meets all the technical requirements of the various box van superstructures.

- LockMaster 890 – Surface-mounted lock
- LockMaster 891 – Built-in lock
- LockMaster NSB – Surface-mounted lock with bow handle
- LockMaster NSE – Surface-mounted lock with flat bar handle
- HingeMaster 895 – Box body hinge

Technology

- The LockMaster 890 is available for several bar diameters. For bar diameter 27 mm there are also the versions:
 - LockMaster NSB with bow handle
 - LockMaster NSE with flat bar handle
- The LockMaster 891 is available with difference recess versions for a bar diameter of 16 mm
- The HingeMaster 895 is available with two different hinge sizes

OVERVIEW



890.16

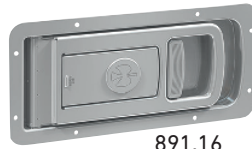

891.16

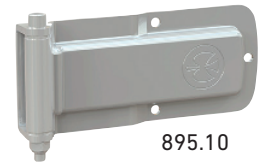

895.10



890.27



NSB



NSE

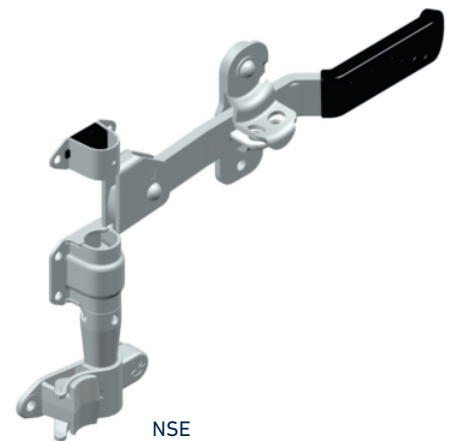

Description	Weight	Order no.
LockMaster 890.16 – Stainless steel, complete without lock	1.705 kg	6.141.703.00
LockMaster 890.27 – Stainless steel, complete without lock	3.841 kg	6.141.702.00
LockMaster 890.27 – Stainless steel, complete with lock	3.939 kg	6.141.726.00
LockMaster 891.16 – Stainless steel, complete without lock	2.159 kg	6.100.212.00
LockMaster 891.20 – Stainless steel, complete without lock	2.5 kg	6.100.215.00
HingeMaster 895.10 – Stainless steel, complete	1.352 kg	6.510.610.00
LockMaster NSB	3.587 kg	6.141.725.00
LockMaster NSE	3.939 kg	6.141.726.00

*Subject to change | Date: July 2016

SURFACE-MOUNTED LOCK – LOCKMASTER 890.16, 890.20, 890.27

The LockMaster 890.16, 890.20, 890.27 is the ideal surface-mounted lock for dry and refrigerated box superstructures.

Technology

- Increased stability with low weight
- Optimised anti-rack properties
- Surface-mounting dimensions allow simple integration into existing door constructions
- Customs version
- Lockable with cylinder or U-lock
- Espagnolette with plastic bearings

Version:

As matching hinges we recommend the HingeMaster 895.10 for the LockMaster 890.27 and the HingeMaster 895.08 for the LockMaster 890.16. Welding points between mounting screws and hinge blade/hinge bracket make the HingeMaster compliant with customs specifications.

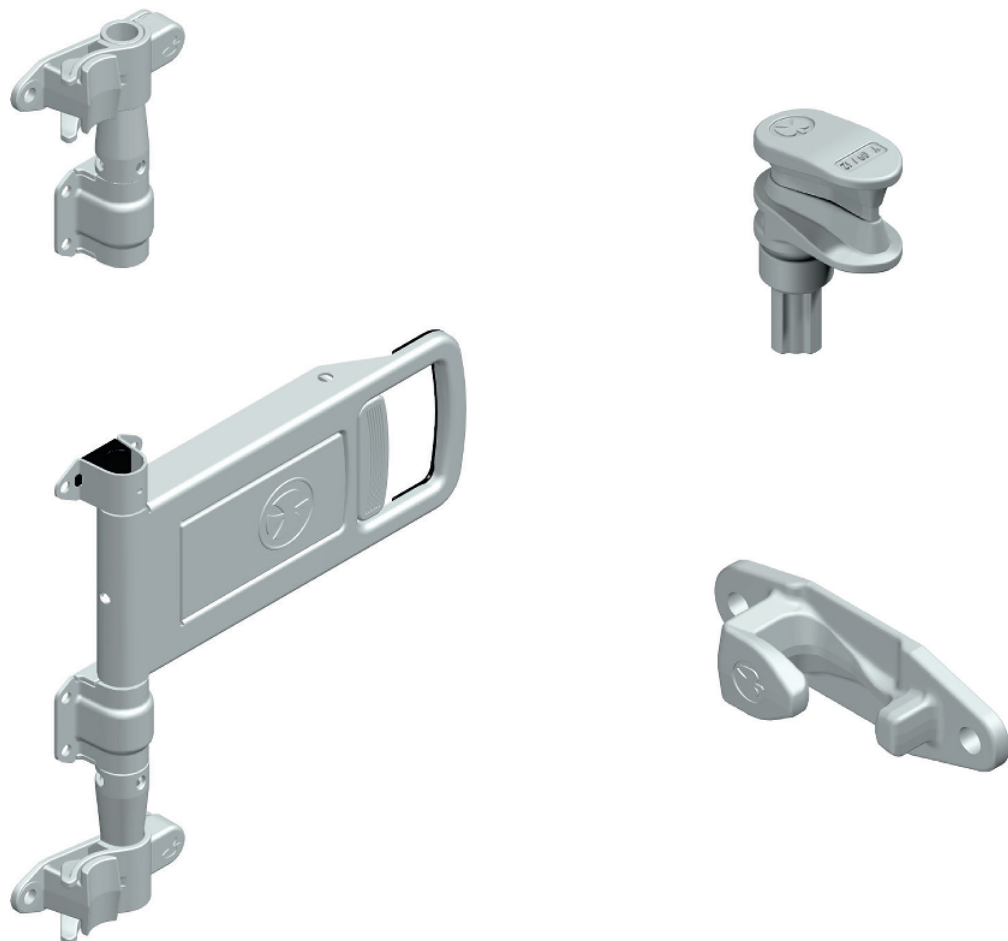

*Subject to change | Date: July 2016

SURFACE-MOUNTED LOCK – LOCKMASTER 890.27

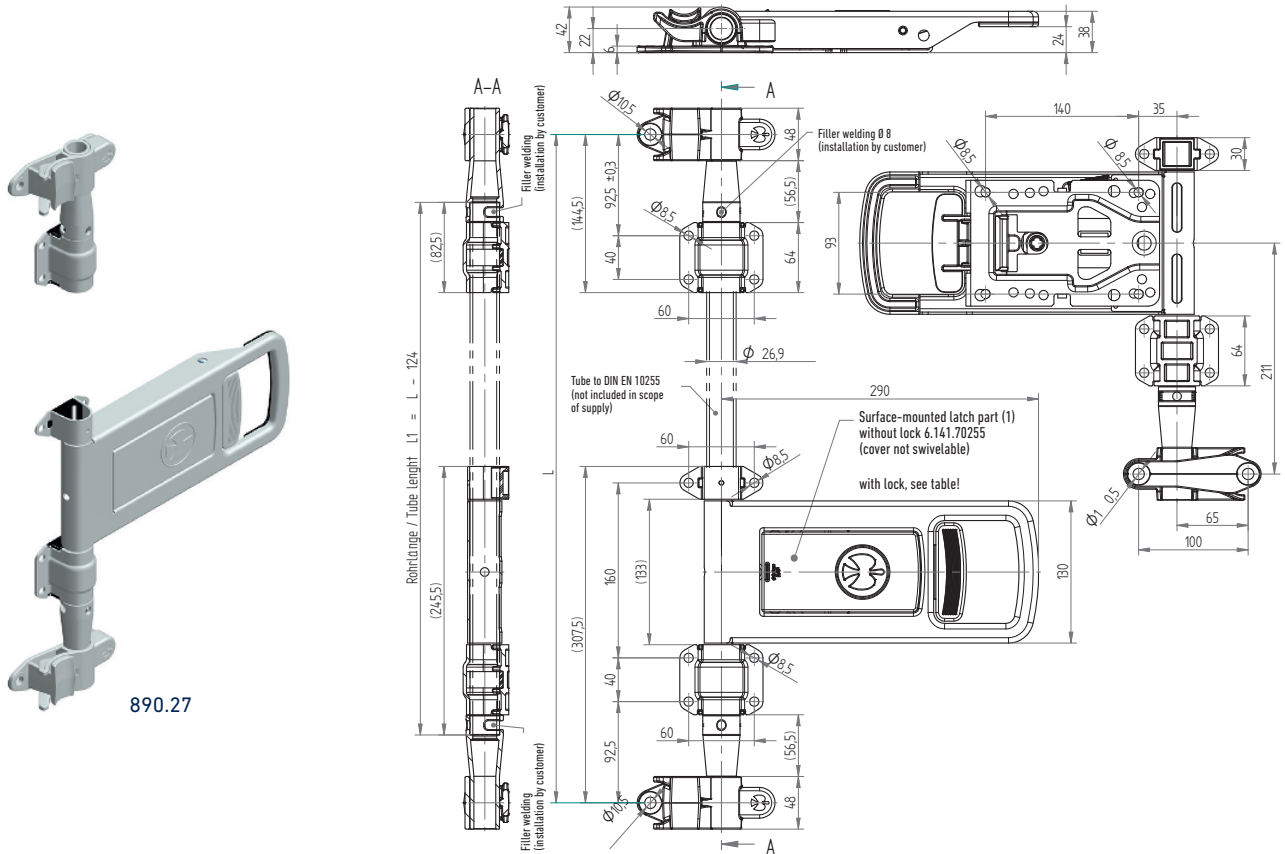

890.27

Description	Weight	Order no.
Counter-holder	0.286 kg	6.141.702.17
Bar holder	0.185 kg	6.141.702.10 (M8) 6.141.702.18 (M10)
Support	0.124 kg	6.141.702.11
Plastic bushing	0.006 kg	6.141.702.12
Bar guide	0.052 kg	6.141.702.13 (M8) 6.141.702.19 (M10)
Guide support	0.009 kg	6.141.702.14
Clamping pin	0.244 kg	6.141.702.15
Clamping pin long, right-hand version, 80 mm	0.474 kg	6.141.702.60
Clamping pin long, right-hand version, 100 mm	0.521 kg	6.141.702.62
Stop tube	0.028 kg	6.140.828.00
Clamping pin long, left-hand version, 80 mm	0.474 kg	6.141.702.61
Clamping pin long, left-hand version, 100 mm	0.521 kg	6.141.702.63
Locking cam for 3/4" tube with 22 mm ID for 1" tube with 27 mm ID	0.485 kg	6.141.094.01
Counter-holder	0.390 kg	6.141.094.02

*Subject to change | Date: July 2016

BUILT-IN LOCK – LOCKMASTER 891.16, 891.20

The LockMaster 891.16 and 891.20 is the ideal built-in lock for dry and refrigerated box superstructures for door thicknesses above 25 mm.

Technology

- Increased stability with low weight
- Outstanding design
- Surface-mounting dimensions allow simple integration into existing door constructions
- Customs version
- Lockable with cylinder lock

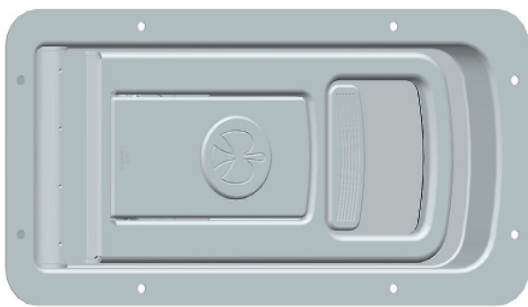

891.16

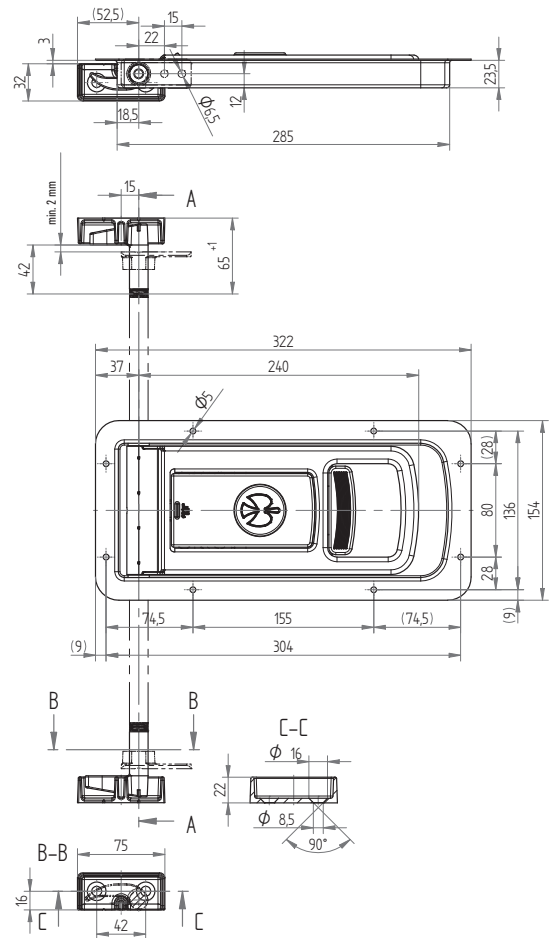
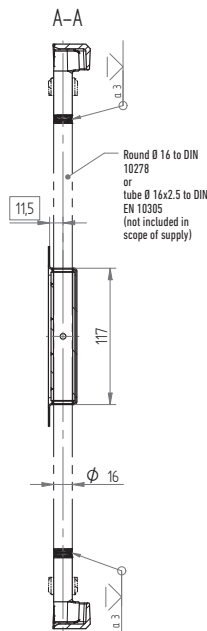





*Subject to change | Date: July 2016

LOCKMASTER 891.16, 891.20 – ACCESSORIES

Figure	Description	Weight	Order no.
	Lock case, low	1.33 kg	6.100.212.15
	Lock case, high	0.187 kg	6.100.212.16
	Guide	0.052 kg	6.100.212.20
	Counter-holder	0.128 kg	6.141.703.17

*Subject to change | Date: July 2016

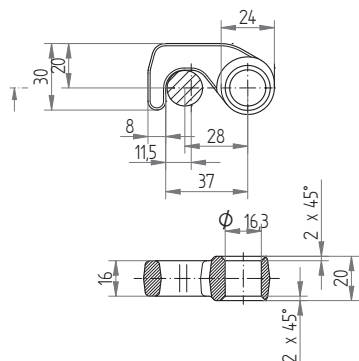
LOCKMASTER 891.16, 891.20 – ACCESSORIES

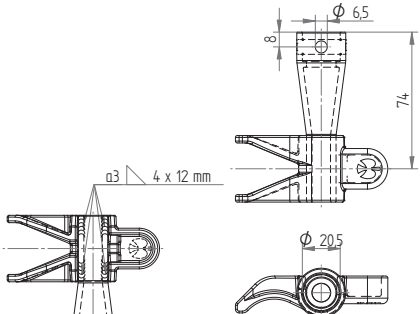
Figure	Description	Weight	Order no.
	Stop ring	0.013 kg	6.141.704.19
	Pin	0.090 kg	6.141.704.20
 	Finger	0.118 kg	6.070.027.01
 	Clamping pin, long Right Left	0.236 kg	6.141.704.60 6.141.704.61

*Subject to change | Date: July 2016

LOCKMASTER 891.16, 891.20 – ACCESSORIES

Figure	Description	Weight	Order no.
	Pivot pin	0.159 kg	6.100.198.01
	Rotating hook Right Left	0.135 kg	6.100.212.10 6.100.212.11
 	Clamping pin	0.121 kg	6.141.703.15
	Stop ring	0.011 kg	6.141.703.16

*Subject to change | Date: July 2016

LOCKMASTER 891.16, 891.20 – ACCESSORIES

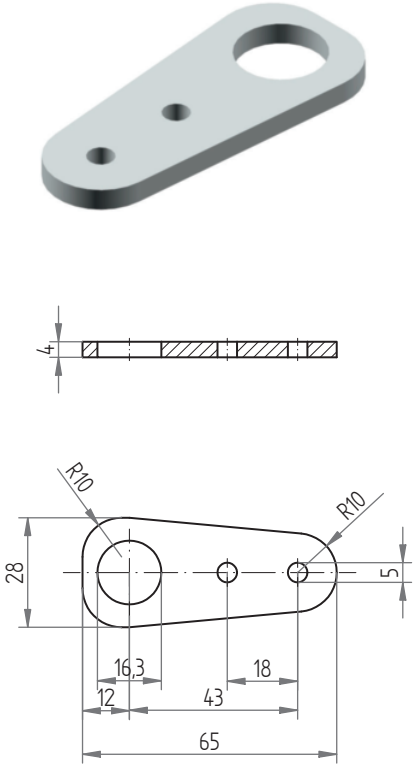
Figure	Description	Weight	Order no.
	<p>Cover plate</p>	<p>0.039 kg</p>	<p>6.070.025.01</p>

*Subject to change | Date: July 2016

LOCKMASTER 891.27 – ACCESSORIES

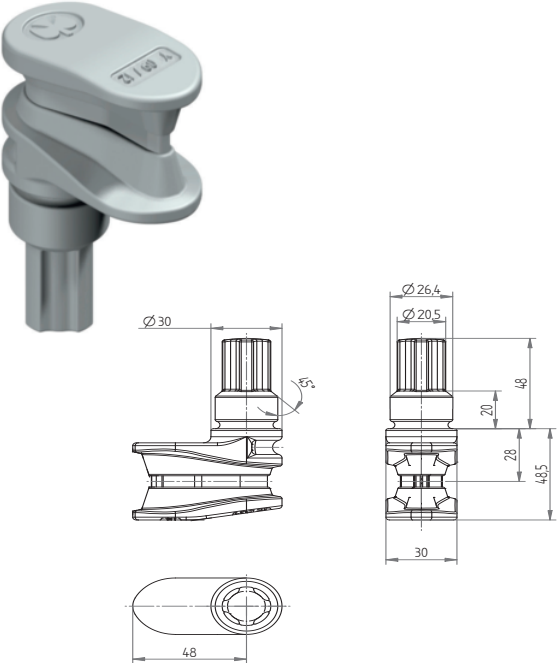
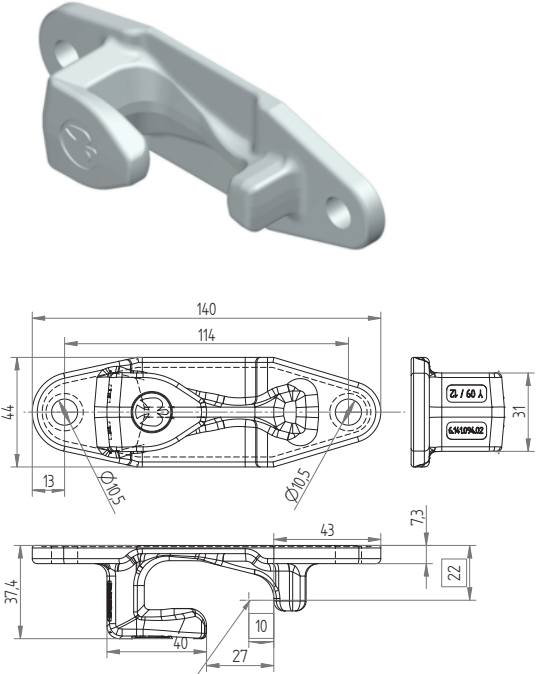
Figure	Description	Weight	Order no.
	<p>Locking cam for 3/4" tube with 22 mm ID for 1" tube with 27 mm ID</p>	<p>0.485 kg</p>	<p>6.141.094.01</p>
	<p>Counter-holder</p>	<p>0.390 kg</p>	<p>6.141.094.02</p>

*Subject to change | Date: July 2016

LOCKMASTER 891.16 – INDIVIDUAL COMPONENTS

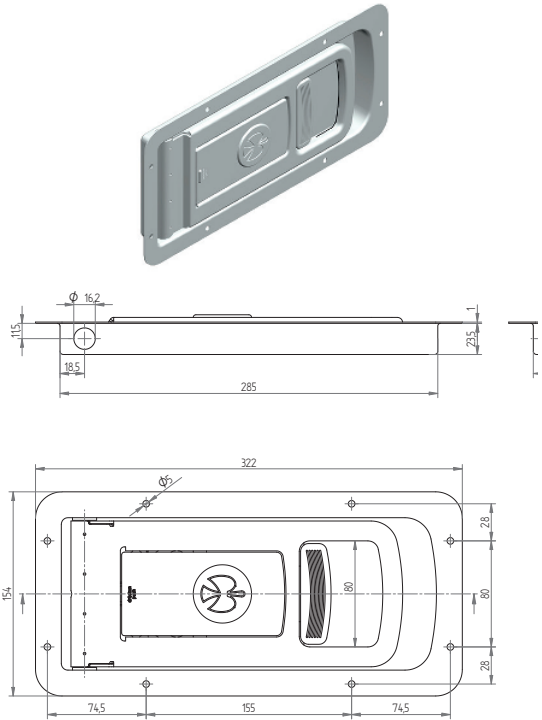
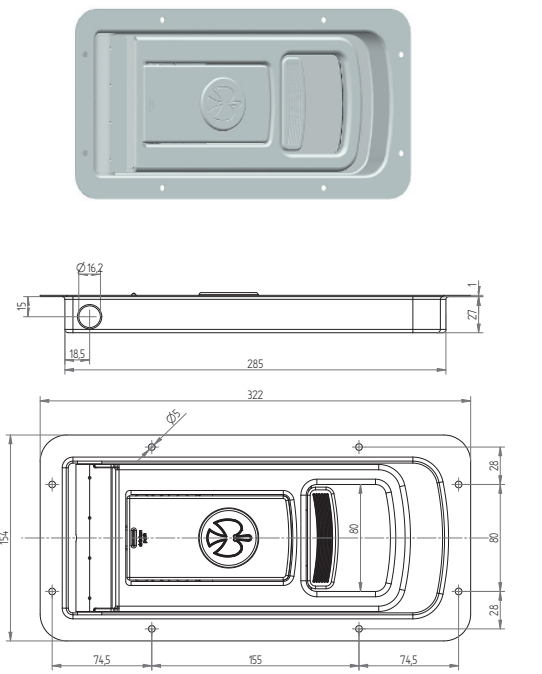
Figure	Description	Weight	Order no.
	<p>Built-in lock element 891.16 Installation depth 23.5 mm Centre-to-centre distance 11.5 mm</p> <p>Without lock 1.553 kg With lock 1.622 kg</p>	<p>6.100.212.55 6.100.216.55</p>	
	<p>Built-in lock element 891.16T Installation depth 27 mm Centre-to-centre distance 15 mm</p> <p>Without lock 1.575 kg With lock 1.644 kg</p>	<p>6.100.213.55 6.100.226.55</p>	

*Subject to change | Date: July 2016

LOCKMASTER 891.16 – INDIVIDUAL COMPONENTS

Figure	Description	Weight	Order no.
	<p>Built-in lock element 888.16 Installation depth 23.5 mm Centre-to-centre distance 12.5 mm</p> <p>Without lock 1.401 kg With lock 1.470 kg</p>		<p>6.100.214.55 6.100.236.55</p>

*Subject to change | Date: July 2016

LOCKMASTER NSB, NSE – SURFACE-MOUNTED LOCK

For a bar diameter of 27 mm, the LockMaster NSB with bow handle and the LockMaster NSE with flat bar handle are also available.

Technology

- Optimised anti-rack properties
- Customs version
- Lockable bow handle
- Plastic-sheathed handle ends allow safe and ergonomic handling
- Improved ergonomics for doors that are difficult to open. They can be easily opened thanks to the integrated opening aid



NSB



NSE

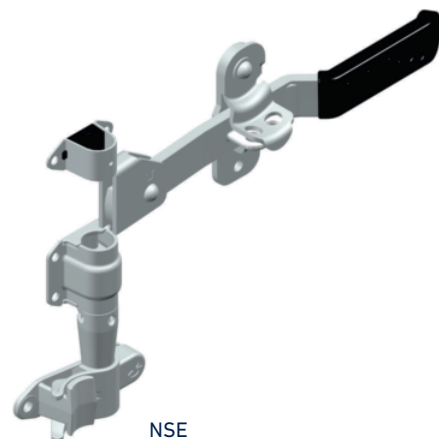

Description	Weight	Order no.
Surface-mounted lock element NSB	3.587 kg	6.141.725.00
Surface-mounted lock element NSE	3.939 kg	6.141.726.00

*Subject to change | Date: July 2016

LOCKMASTER NSB, NSE

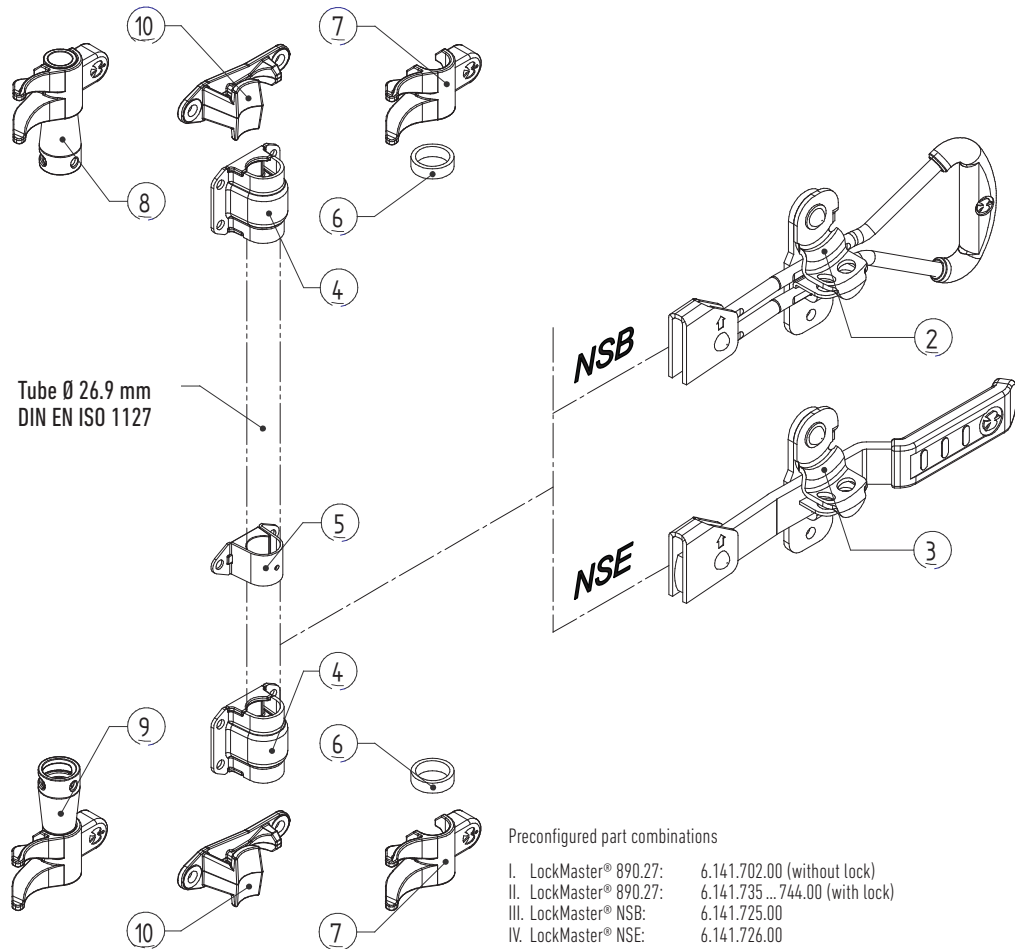

Pos.	Description	Weight	Order no.
1	Surface-mounted lock element 890.27 stainless steel, without lock and hinged lid	1.650 kg	6.141.702.55
1.1	Surface-mounted lock element 890.27 stainless steel, with hinged lid	1.650 kg	6.141.702.56
1.2	Surface-mounted lock element 890.27 stainless steel, with lock and hinged lid	1.700 kg	6.141.735 ... 744.55
2	Surface-mounted lock element NSB stainless steel	1.377 kg	6.141.725.55
3	Surface-mounted lock element NSE stainless steel	1.647 kg	6.141.726.55
4	Bar holder	0.185 kg	6.141.702.10
	Support	0.124 kg	6.141.702.11
	Plastic bushing	0.006 kg	6.141.702.12
5	Bar guide	0.052 kg	6.141.702.13
	Guide support	0.009 kg	6.141.702.14
6	Stop tube	0.028 kg	6.140.828.00
7	Clamping pin	0.244 kg	6.141.702.15
8	Clamping pin long, right-hand version	0.474 kg	6.141.702.60
9	Clamping pin long, left-hand version	0.474 kg	6.141.702.61
10	Counter-holder	0.286 kg	6.141.702.17

*Subject to change | Date: July 2016

SURFACE-MOUNTED HINGE – HINGEMASTER 895

The HingeMaster 895 is an ideal surface-mounted hinge for dry and refrigerated box superstructures.

Technology

- Increased stability with low weight
- Optimised anti-rack properties
- Surface-mounting dimensions allow simple integration into existing door constructions
- Inside opening possible
- Customs version

HingeMaster 895 is the matching hinge for the LockMaster 890 and 891. As matching hinges we recommend the HingeMaster 895.10 for the LockMaster 890.27 and the HingeMaster 895.08 for the LockMaster 890.16.

Welding points between mounting screws and hinge blade/hinge bracket make the HingeMaster compliant with customs specifications.

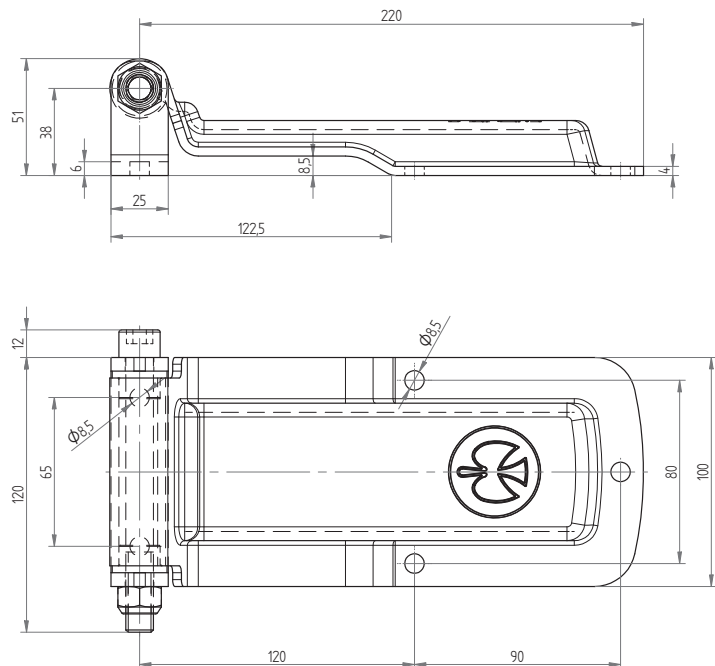

*Subject to change | Date: July 2016

OVERVIEW



Fastener 664N

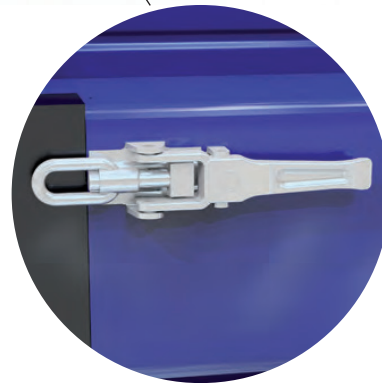

Fastener 6043S

- Elbow handle fastener
- Universal fastener
- Eccentric fastener
- Tipper fastener

FASTENERS FOR TIPPER SUPERSTRUCTURES AND CAR TRAILERS

Fields of application

HESTAL offers a complete portfolio of all various fasteners for tipper superstructures and car trailers.

The proven solutions for tipper superstructures and car trailers in overview:

- 664N – Tipper fastener
- 6121N – Elbow handle fastener
- 60450 – Eccentric fastener
- 6043, 6043S – Eccentric fastener
- 6022, 6022S – Elbow handle fastener
- 603 – Two-sided tipper fastener

Technology

- Individual customer demands -> through effective and efficient use of technology and design
- HESTAL fasteners are characterised by high strength, compact design and long service life
- Each design is robust, reduces wear and meets the demands for health & safety at work
- Only high-strength materials are used for production

ELBOW HANDLE FASTENER 6022

The 6022 fasteners are extremely flat with a mounting height of 27 mm. The hand lever rises by 50 mm during opening. Long service life thanks to wear-reducing design.

Typical fields of application

- Flatbed vehicles and tippers
- Steel drop-sides
- Aluminium drop-sides

Technology

- The fasteners lift off thanks to the inclined position of the pivot shaft, thus allowing easy opening with a large hand lever freedom
- The mechanical moving rotor retainer holds the fasteners in the closed position

Installation instructions

Fastener 6022 is bolted on

Versions

6022 Raw or electrogalvanised to FHS-TL 9.01

Accessories

6023 Bolt-on cam, raw

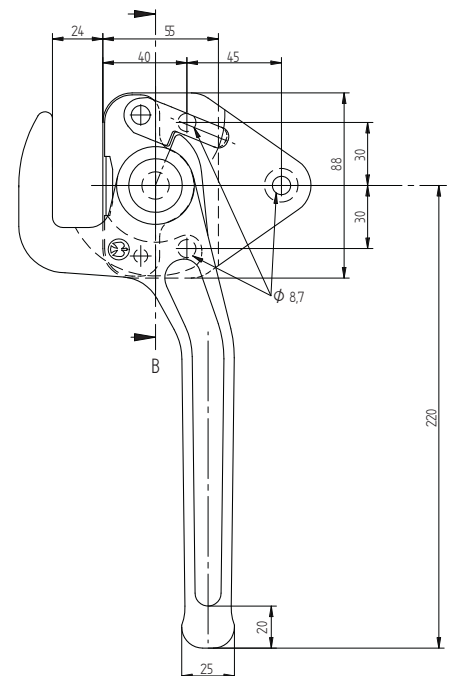

6022

Type	Description	Weight	Order no.
6022	Latch right, galvanised	1.05 kg	6.040.079.00
6022	Latch left, galvanised	1.05 kg	6.040.080.00

*Subject to change | Date: July 2016

ELBOW HANDLE FASTENER 6121N

Equipped with an integrated semi-automatic retaining device.

Typical fields of application

- Main fields of application are car trailers and horse boxes
- Steel or aluminium drop-sides
- The fastener baseplate is fastened to the drop-side using three fillister head screws M8 DIN 6912

Technology

- An integrated semi-automatic pushbutton locks the fastener in the closed position
Parallel movement of the hand lever to the drop-side, hence no protrusion into the traffic area
- Compact design and high-strength material
- Available as a bolt-on version
- Galvanised surface

Versions

Hot-dip galvanised to FHS-TL 9.01

Accessories

607/1 Eye bracket, electrogalvanised to FHS-TL 9.01, bolt-on

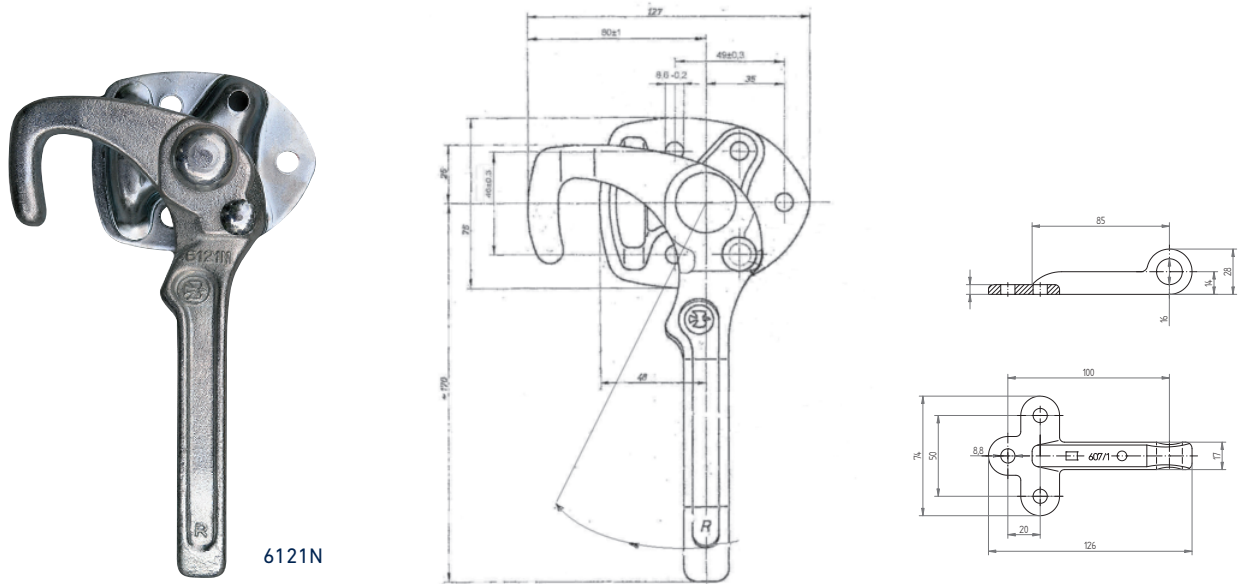

Type	Description	Weight	Order no.
6121N	Elbow handle fastener left, galvanised	0.72 kg	6.020.143.00
6121N	Elbow handle fastener right, galvanised	0.72 kg	6.020.142.00
607/1	Eye bracket, galvanised		6.011.059.99

*Subject to change | Date: July 2016

UNIVERSAL FASTENER 603

The 603 fastener is a surface-mounted fastener with a mounting height of 37 mm. Its special design and reliability are its main characteristics.

Typical fields of application

- Tipper superstructures of all kinds
- Superstructures with and without corner pillars

Technology

- The fastener hook is integrated into the hand lever part so that the retaining cam can be easily moved to the locking position
- The 603 fastener achieves its excellent closing function thanks to the large chamfer above the hand lever part

Versions

Raw or electrogalvanised to FHS-TL 9.01

Accessories

6030/6030S/6031S, retaining cam

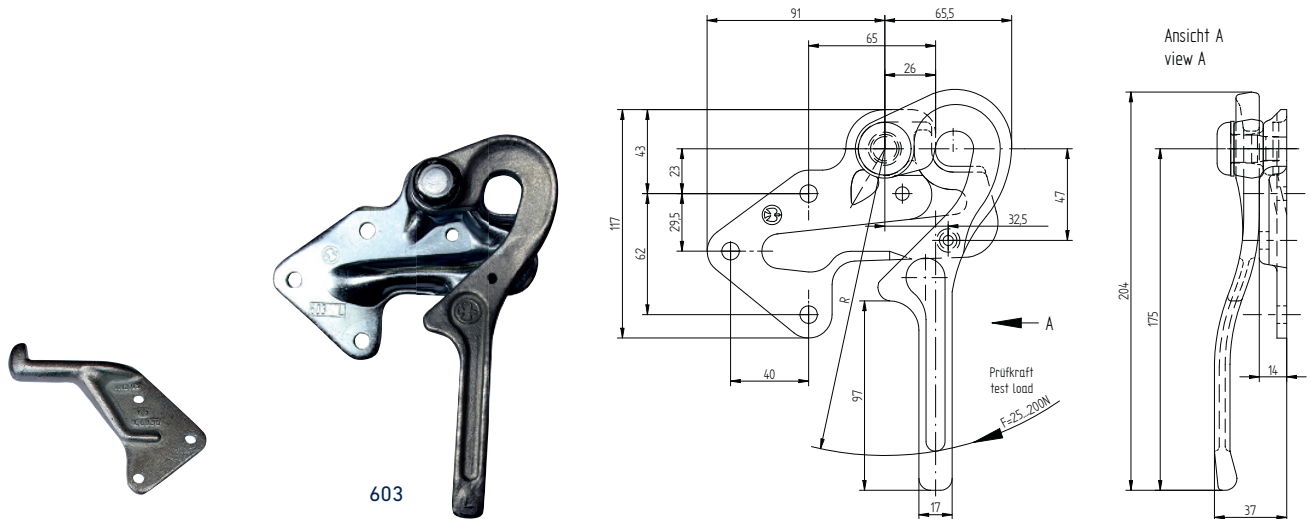

Type	Description	Weight	Order no.
603	Fastener right, galvanised	0.75 kg	6.020.167.00
603	Fastener left, galvanised	0.75 kg	6.020.168.00
6030	Retaining cam right, galvanised	0.40 kg	6.030.089.99
6030	Retaining cam left, galvanised	0.40 kg	6.030.090.99

*Subject to change | Date: July 2016

ECCENTRIC FASTENER 6043, 6043S

The eccentric fasteners are length-adjustable thanks to a thread. They are available in 2 versions, with and without locking device.

Typical fields of application

- Car trailers and special tipper superstructures
- Spare wheel holders, toolboxes, transport containers in the packaging, construction machinery and building industry, as well as container and mould making

Technology

- Fasteners can be welded or bolted on, the mounting height is additional 35 mm
- The eccentric top arm is the primary locking element. The additional integrated frictional locking device prevents accidental opening. The locking device is located under the hand lever and engages in the baseplate

Versions

Electrogalvanised to FHS-TL 9.01 or raw

Accessories

- 6044 Retaining cam for bolting
- 6044S Retaining cam for welding

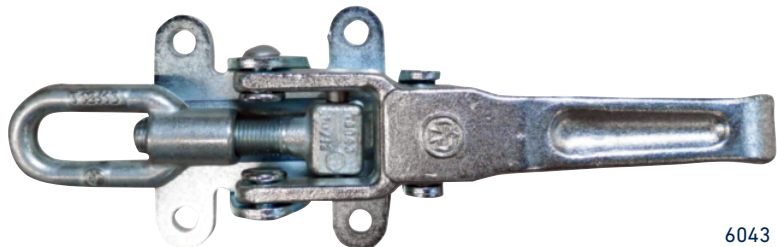

6043



6043S

*Subject to change | Date: July 2016

ECCENTRIC FASTENER 6043, 6043S

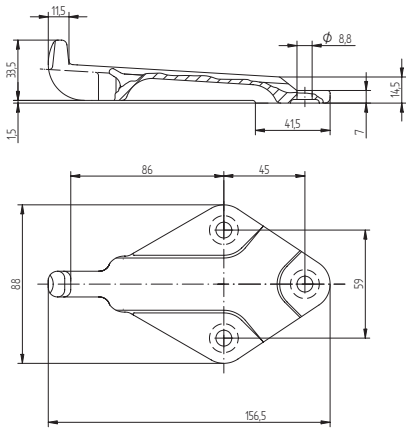

6044

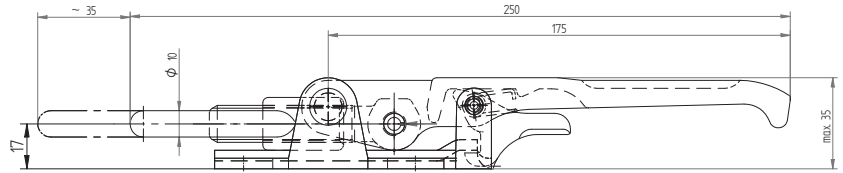

6043

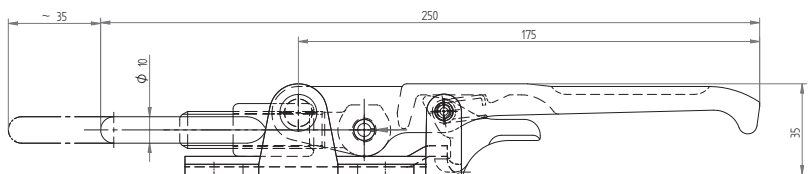
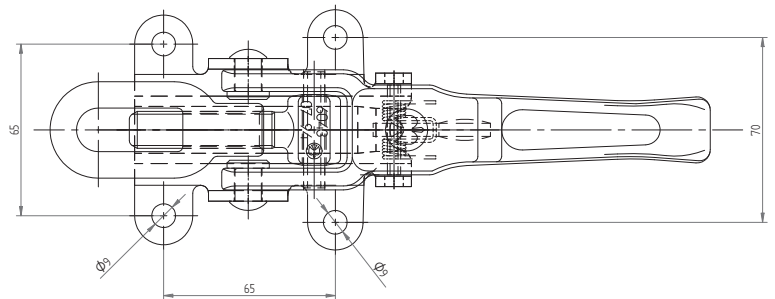

6043S

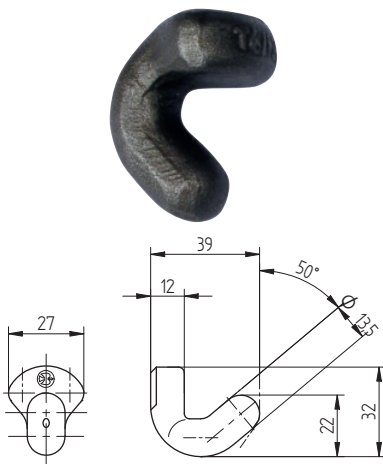
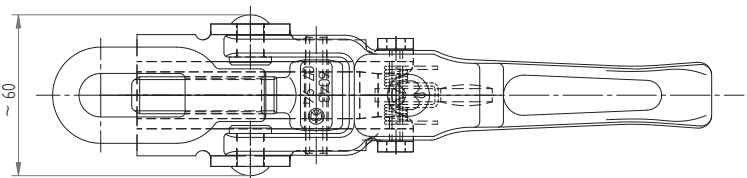

6044S

Type	Description	Mounting height	Weight	Order no.	
				non-galvanised	galvanised
6043	Eccentric fastener without integrated locking mechanism	35 mm	0.860 kg	6.020.047.00	6.020.120.00
	with integrated positive locking mechanism	35 mm	0.880 kg	6.020.383.00	6.020.390.00
6044	Retaining cam, for bolting	35 mm	0.461 kg	6.030.018.00	6.030.077.99
6043S	Eccentric fastener without integrated locking mechanism	35 mm	0.810 kg	6.020.048.00	n.a.
	with integrated positive locking mechanism	35 mm	0.840 kg	6.020.384.00	n.a.
6044S	Retaining cam, for welding	-	0.074 kg	6.030.075.99	n.a.

*Subject to change | Date: July 2016

ECCENTRIC FASTENER 60450, 60451 – ADJUSTABLE

60450 Screw-in eyebolt in the latch element.

60451 Screw-in hook in the latch element.

Typical fields of application

- Car trailers and light flatbed superstructures; containers for trucks that hold a spare wheel or accessories; tool-boxes or transport containers
- The fastener is also used in the packaging industry, in container and mould making or in the construction machinery and building industry
- Securing of tarpaulins to vehicles

Technology

- The eccentric top arm of the fasteners holds the fastener in the locked position, but must be additionally secured with clip pins

Versions

Electrogalvanised to FHS-TL 9.01 or stainless steel, electropolished

Accessories

60455 Counter-holder, straight

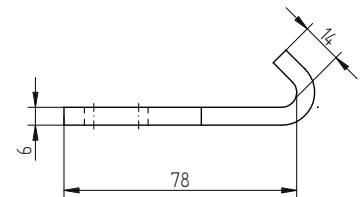
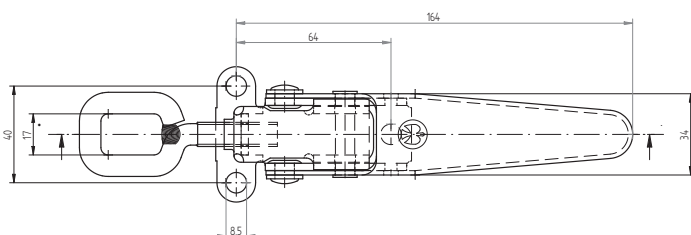
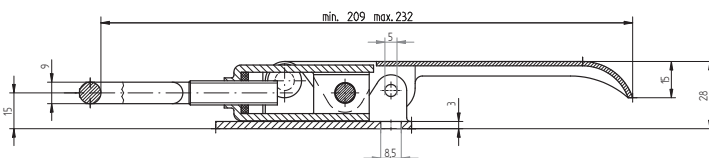

60455



60450

Type	Description	Weight	Order no.
60450	Eccentric fastener, adjustable, galvanised	0.35 kg	6.020.709.00
	Eccentric fastener, adjustable, stainless steel	0.35 kg	6.020.706.00
60455	Counter-holder, straight, for version 60450	0.06 kg	6.030.052.00
60451	Eccentric fastener, galvanised	0,35 kg	6.020.710.00

*Subject to change | Date: July 2016

TIPPER FASTENER 662N, 662NP

- Equipped with automatic lock adjustment
- One-handed operation and sturdiness thanks to use of high-strength materials
- Suitable for steel or aluminium tipper drop-sides

Typical fields of application

- 662NP specially for pallet tipper superstructures
- Short version for drop-side heights of 600 mm - 800 mm,
Long version for drop-side heights of 1000 mm - 1200 mm

Technology

- One-handed operation/sturdiness
- Good closing behaviour – radial 32 mm and axial 8 mm
- Double over-dead-centre locking in combination with a hand lever locking device
- Automatic lock adjustment compensates installation tolerances and wear

Versions

Non-galvanised, raw

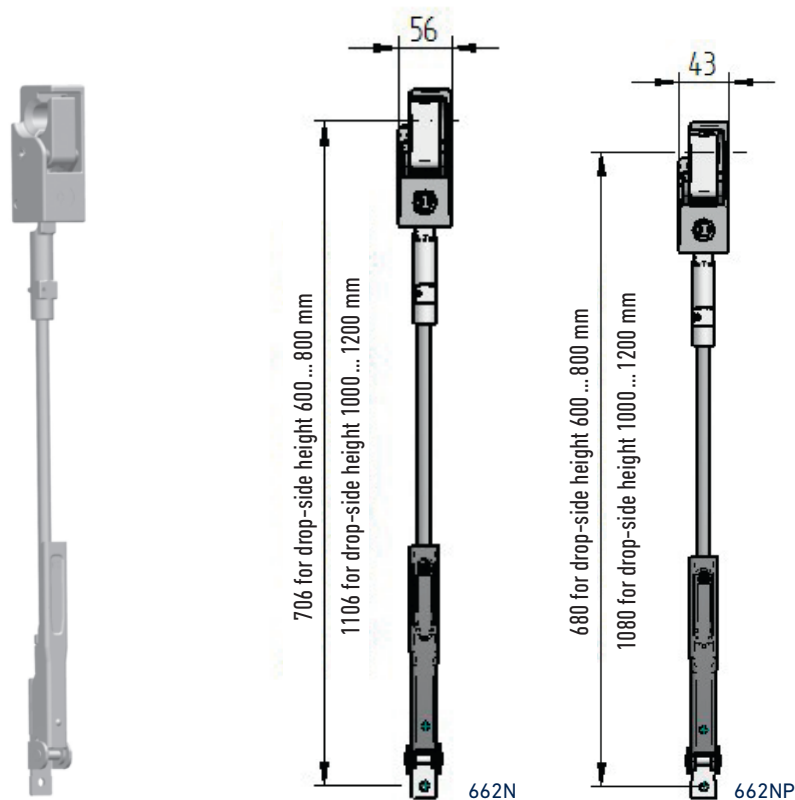

*Subject to change | Date: July 2016

TIPPER FASTENER 662N/662NP

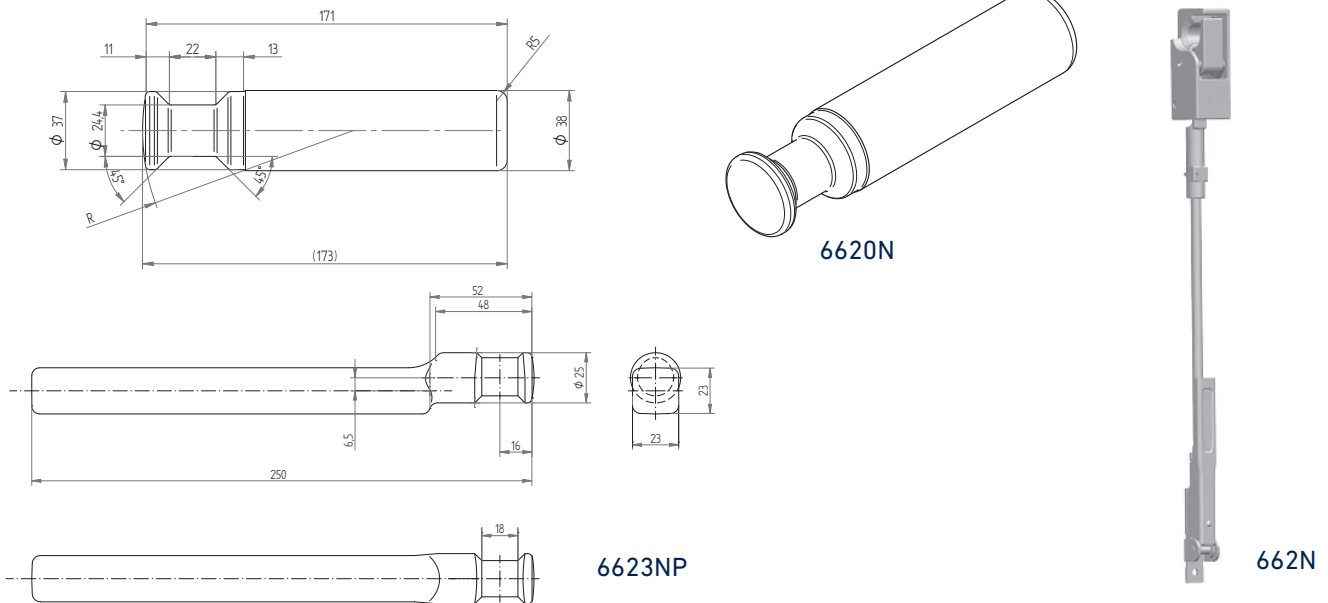

Type	Description	Weight	Order no.
662N	Latch with thread bar 6624N, for drop-side-height from 600 mm - 800 mm Left Right	3.40 kg	6.020.309.00 6.020.308.00
662N	Locking part Left Right	2.73 kg	6.020.313.00 6.020.312.00
662N	Latch with thread bar 6625N, for drop-side-height from 1000 mm - 1200 mm Left Right	3.8 kg	6.020.311.00 6.020.310.00
662N	Locking part Left Right	3.1 kg	6.020.315.00 6.020.314.00
6620N	Floating pin	1.36 kg	6.030.097.01
662NP	Latch with thread bar 6624N, for drop-side-height from 600 mm - 800 mm Left Right	2.4 kg	6.020.303.00 6.020.302.00
662NP	Locking part Left Right	1.67 kg	6.020.300.00 6.020.299.00
662NP	Latch with thread bar 6625N, for drop-side-height from 1000 mm - 1200 mm Left Right	2.85 kg	6.020.305.00 6.020.304.00
662NP	Locking part Left Right	2.15 kg	6.020.307.00 6.020.306.00
6623NP	Floating pin	0.925 kg	6.031.132.99

*Subject to change | Date: July 2016

TIPPER FASTENER 664N

- With automatic lock adjustment
- Automatic locking under the hand lever
- One-handed operation

Typical fields of application

- For commercial and agricultural tipper superstructure
- With steel or aluminium drop-sides, the 664N fastener is installed on middle or corner pillars
- The pendulum is fastened to the upper edge of the drop-side
- With narrow pillar profiles or compact designs, the fasteners with laterally offset hand lever must be installed so that a clearance for the fingers of at least 25 mm to the folding or swinging tipper drop-side is maintained

Advantages / benefits

- Closing behaviour – radial 32 mm and axial ± 8 mm
- Available with laterally offset or straight hand lever
- Double over-dead-centre locking in combination with the lock under the hand lever prevents accidental opening
- Automatic lock adjustment (compensates installation tolerances and wear, clearance-free alignment of closing hook with pendulum pin in bearing housing)
- Straight pendulum pin 6640N or cropped pendulum pin 6623 NP allows a wide range of installation possibilities. Pendulum pin 6641N is mounted on the drop-side
- All fastener parts satisfy the occupational health and safety regulations

Versions

Raw or electrogalvanised to FHS-TL 9.01



*Subject to change | Date: July 2016

TIPPER FASTENER 664N

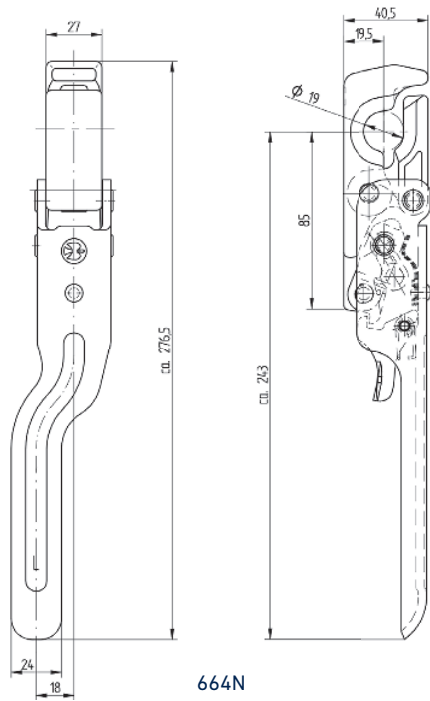

664N

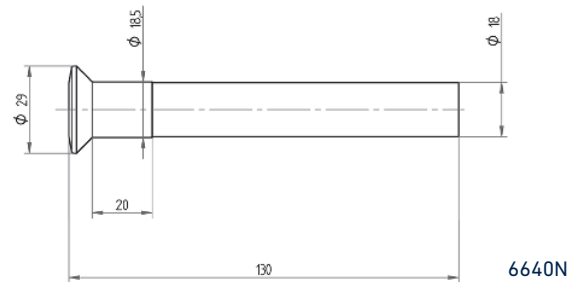

6640N

Type	Description	Weight	Order no.
664N	Tipper fastener, raw with automatic positive-fit locking mechanism, straight	0.90 kg	6.020.124.00
664N	Tipper fastener, raw with automatic positive-fit locking mechanism Left Right	0.91 kg	6.020.128.00 6.020.127.00
664N	Tipper fastener, galvanised with automatic positive-fit locking mechanism, straight	0.91 kg	6.020.265.00
664N	Tipper fastener, galvanised with automatic positive-fit locking mechanism Left Right	0.94 kg	6.020.286.00 6.020.285.00
6623NP	Pendulum pin	0.93 kg	6.031.132.99
6640N	Pendulum bolt, raw	0.27 kg	6.031.078.00
6641N	Retaining cam, galvanised Left Right	0.49 kg	6.031.124.99 6.031.123.99

*Subject to change | Date: July 2016

Figure	Article designation	Reference	Order no.
	<p>Dampers set for telescope 912 Damping strips Flanged button-head screws M8x30 Hexagon nuts M8 Washer 8-200HV</p>	Telescope 912	6.850.035.00
	<p>Tensioning cable set for telescope 912 Tensioning cable assembly 630 long Hemlok rivet 6.4 x 19.0 Blind rivet 4.8 x 14.7</p>	Telescope 912	6.850.036.00
	<p>Locking set for VarioMaster 900 Pressure spring locking slide Flat-head M-Lock blind rivet</p>	VarioMaster 900	6.850.038.00
	<p>Dampers set for telescope 912 Damping strip spacer Hexagon bolt M8x18 Hexagon nut M8 self-locking</p>	Telescope 912	6.850.041.00

*Subject to change | Date: July 2016

Figure	Article designation	Reference	Order no.
	Spare parts set 1 for strap lift system 501 Spring hook 8 for cable Ø 8 mm Delta bracket for tensioner belt 50 x Ø 8 mm Package leaflet Package leaflet rear side Ziplock bag DIN A5	Strap lift system 501	6.850.039.01
	Spare parts set 2 for strap lift system 501 Guide roller assy. Package leaflet Package leaflet rear side Ziplock bag DIN A5	Strap lift system 501	6.850.039.02
	Spare parts set for hand lever mechanism SolidMaster 801 BG drive Bolt Ø 8x75 Bolt Ø 8x110 Repair instructions Drawing Ziplock bag DIN A5	SolidMaster 801	6.850.040.00
	Spare part set lift mechanism 770N 300 mm Spare part set lift mechanism 770N 400 mm Spare part set lift mechanism 770N 500 mm Blocking spring Bearing bush Lock washer 12 Cup spring A28F Washer 15 Pressure spring Ø 1.6 x 20 x 73.5 Thrust rod Cylinder pin Ø 4h8 x 26 Conversion Instructions Shipping tube HESTAL "original spare parts" plastic bag Weicon-lock AN 306-30 20 ml	LiftMaster 770N	6.850.042.03 6.850.042.04 6.850.042.05

*Subject to change | Date: July 2016

Figure	Article designation	Reference	Order no.
	<p>Spare part for LiftMaster 770N hand lever with release mechanism BG4 hand lever profile Bearing ring with twist lock Bearing bolt</p>	LiftMaster 770N	6.850.057.00
	<p>Lift limit hand lever for LiftMaster 770N Stop belt Fillister head screw M5x55 Self-locking nut M5 with press-fit washer</p>	LiftMaster 770N	6.850.058.00
	<p>Installation set for TensionMaster II squared shaft version Squared tensioner shaft M washer Rivet Untightening sticker – German Untightening sticker – English Installation instructions Operation sticker Ziplock bag</p>	TensionMaster II	6.850.052.00
	<p>Installation set for TensionMaster II slotted shaft version Slotted shaft M washer Rivet Untightening sticker – German Untightening sticker – English Installation instructions Operation sticker Ziplock bag</p>	TensionMaster II	6.850.053.00

*Subject to change | Date: July 2016

Figure	Article designation	Reference	Order no.
	<p>SolidMaster 801 accessory set Bolt-on pillar pocket Countersunk head screw M8x16 Threaded plate Latch pocket right</p>	SolidMaster 801	6.850.047.00
	<p>SolidMaster 801 accessory set Bolt-on pillar pocket Countersunk head screw M8x16 Threaded plate Flat pocket R+L</p>	SolidMaster 801	6.850.048.00 6.850.049.00 6.850.050.00
	<p>SolidMaster 801 accessory set Bolt-on pillar pocket Countersunk head screw Threaded plate Latch pocket left</p>	SolidMaster 801	6.850.051.00
	<p>SolidMaster 801 accessory set Bolt-on pillar pocket Fillister head screw M8x16 Threaded plate Latch pocket</p>	SolidMaster 801	6.850.054.00 6.850.055.00

*Subject to change | Date: July 2016

HESTAL SMARTMASTER CONFIGURATION

Date: _____ Customer No.: _____ Drawing No. _____

Customer's address: _____

1. Version: Sandwich Aluminium Aluminium – completely anodised

2. Vehicle overall width: _____ mm Portal inside height (i.L.): _____ mm (Door size + 30 mm)
Width (standard 2550) Height

3. Hinge type: Pin bolted to the side Pin welded to the front Pin bolted to the front Screw pin bolted to the front Screw pin welded to the front

4. Number of hinges per door sash: _____ Pivot arm: with stop without stop

5. Latches per door sash: _____ Latches per portal: _____

6. Latches with lock: _____ with lock Locking mechanism: 1 2 3 4 5 6 7 8 9 10
(1 Standard)

7. Door fix: yes no

8. Distance from door lower edge to middle of fastener: _____ mm (50 = Standard)

9. Distance from door lower edge to middle of clamping pin: _____ mm (32 = Standard)

10. Second clamping pin? yes no _____ mm
(with roof lift system) Distance between clamping pin + height of upper clamping pin

CONFIGURATION TEMPLATES

HESTAL SMARTMASTER CONFIGURATION

Accessories:

11. Sandwich with laminated foil or painted:

Sandwich untreated	<input type="checkbox"/>		
Yes, one side with foil	<input type="checkbox"/>	If yes	RAL: _____
Yes, both sides with foil	<input type="checkbox"/>	If yes	RAL: _____
Yes, one side painted	<input type="checkbox"/>	If yes	RAL: _____
Yes, both sides painted	<input type="checkbox"/>	If yes	RAL: _____
Aluminium door, no sandwich installed	<input type="checkbox"/>		

12. Powder coating:
(both sides of frame)

yes no If yes RAL: _____

Hinge also powder coated, only with bolted version

yes no

13. Coating of aluminium inlay:

No further surface treatment	<input type="checkbox"/>		
Powder coated on one side	<input type="checkbox"/>	If yes	RAL: _____
Powder coated on both sides	<input type="checkbox"/>	If yes	RAL: _____
Covered with foil on one side	<input type="checkbox"/>	If yes	RAL: _____
Covered with foil on both sides	<input type="checkbox"/>	If yes	RAL: _____
Sandwich door, no aluminium inlay installed	<input type="checkbox"/>		

14. Door seal: Silicone

15. Contour marking:

yes no

16. Scuff protection rail:

yes no

17. Advertising foils:

yes no

18. Number of portals:

19. Remarks:

20. Completed on/by:

CONFIGURATION TEMPLATES

HESTAL HS 25 DROP-SIDES CONFIGURATION

Date: _____

Customer No.: _____

Customer's address: _____

End user: Name _____

End user: Address _____

Dimensions: Height: _____ Width: _____ Thickness: 25 mm

Raw Anodised Powder primed

Powder coated in RAL _____

Upper end profile	Height	Order number	Qty.	Remarks
	50 mm	660000113	<input type="checkbox"/>	
	50 mm	660000136	<input type="checkbox"/>	
	100 mm	660000114	<input type="checkbox"/>	
	150 mm	660000115	<input type="checkbox"/>	
	200 mm	660000116	<input type="checkbox"/>	
	200 mm	660000140	<input type="checkbox"/>	
Middle profile	100 mm	660000106	<input type="checkbox"/>	
	200 mm	660000108	<input type="checkbox"/>	
	200 mm	660000138	<input type="checkbox"/>	
	200 mm	660000139	<input type="checkbox"/>	
	300 mm	660000124	<input type="checkbox"/>	
Middle profile for curtain clamps	150 mm	660000109	<input type="checkbox"/>	
	200 mm	660000110	<input type="checkbox"/>	
Lower end profile	200 mm	660000103	<input type="checkbox"/>	with rain lug
	200 mm	660000105	<input type="checkbox"/>	with rubber seal
	200 mm	660000135	<input type="checkbox"/>	
	200 mm	660000137	<input type="checkbox"/>	
	350 mm	660000127	<input type="checkbox"/>	Special profile
Folding step	150 mm	660000112	<input type="checkbox"/>	
	200 mm	660000111	<input type="checkbox"/>	
Sliding stone profile		660000128	<input type="checkbox"/>	with curtain clamps/hooks
		660000130	<input type="checkbox"/>	with curtain clamps/hooks
Bezel for		660000117	<input type="checkbox"/>	
Middle pillar	801	660000120	<input type="checkbox"/>	
	802	660000118	<input type="checkbox"/>	
Corner pillar	801	660000122	<input type="checkbox"/>	
	802	660000119	<input type="checkbox"/>	
Adjustment cap		660000141	<input type="checkbox"/>	
Seal		660000147	<input type="checkbox"/>	
		660000148	<input type="checkbox"/>	
Pillar used	801	<input type="checkbox"/>	Hinged pillar with one lever	
	802	<input type="checkbox"/>	Hinged pillar with two levers	
	900	<input type="checkbox"/>	Curtainsider pillar	
		<input type="checkbox"/>	Rear drop-side	
Type of fastener	710	<input type="checkbox"/>	single locking	682 <input type="checkbox"/> clamped
	715	<input type="checkbox"/>	double locking	686 <input type="checkbox"/> clamped
	681	<input type="checkbox"/>	clamped	604 <input type="checkbox"/> clamped

Remarks: _____

SLIMMASTER



SMARTMASTER 500S



SMARTMASTER 500A



SMARTMASTER II



Auto Partner

Urkunde

Die Fachgruppe der TÜV SÜD Ladungssicherung bestätigt der
F. Hesterberg & Söhne GmbH & Co. KG, 58256 Ennepetal

die Übereinstimmung der
F. Hesterberg & Söhne GmbH & Co. KG
Türkonfiguration Typ SmartMaster
mit den derzeit geltenden Anforderungen und Regeln der
Technik zur Ladegutsicherung.
Getestet und Zertifiziert nach Grundlage des Anforderungsprofils
der Norm DIN EN 12642 Stand 2006 Code XL Anhang A
Diese Urkunde bezieht sich auf das TÜV SÜD Auto Partner
Zertifikat mit der Nummer 20160307H-1

Ochtrup, 13.04.2016



Auto Partner

Dipl.- Ing. (FH) Thorsten Ludwig

SMARTMASTER II



Auto Partner

Urkunde

Die Fachgruppe der TÜV SÜD Ladungssicherung bestätigt der
F. Hesterberg & Söhne GmbH & Co. KG, 58256 Ennepetal

die Übereinstimmung der
F. Hesterberg & Söhne GmbH & Co. KG
Türkonfiguration Typ SmartMaster
mit den derzeit geltenden Anforderungen und Regeln der
Technik zur Ladegutsicherung.
Getestet und Zertifiziert nach Grundlage des Anforderungsprofils
der Norm DIN EN 12642 Stand 2006 Code XL Anhang A
Diese Urkunde bezieht sich auf das TÜV SÜD Auto Partner
Zertifikat mit der Nummer 20160307H-2

Ochtrup, 13.04.2016



Auto Partner

Dipl.- Ing. (FH) Thorsten Ludwig

SOLIDMASTER



ZERTIFIKAT

AG70/11068/2008-18574-3
F. Hesterberg & Söhne
D-58256 Ennepetal

HESTAL-SolidMaster-Klappungen vom Typ 801 und 802 Code L und XL bis zu 3.000 mm, HESTAL-Konstruktionsmatrix AG70/11068/2008-18574-3, erfüllen die derzeit geltenden Anforderungen und Regeln der Technik zur Nutzfahrzeugaufbaustabilität und zur Ladungssicherung, gemäß dem DEKRA-Rungenanforderungsprofil[®], den Richtlinien VDI 2700 und 2700 Blatt 3, den Normen DIN-EN 12195-1, DIN EN 12642 Code L und Code XL Anhang A und B, sowie der DAIMLER Richtlinie DE-RL. 9.5

D-01998 Klettwitz, 12. September 2008



Dipl.- Ing. Matthias STENAU
DEKRA Automobil GmbH
Technology-Center
Senftenberger Strasse 30
D-01998 Klettwitz

DEKRA Automobil GmbH
Handwerkstraße 15
D-70565 Stuttgart
Telefon 00 49 / 7 11 / 78 61-0
Telefax 00 49 / 7 11 / 78 61-22 40
www.dekra.com

Sitz Stuttgart, Amtsgericht Stuttgart,
HRB-Nr. 21039
Ust.-ID-Nr. DE 811 297 970
Steuer-Nr. 99015/01322
Bankverbindung:
Dresdner Bank AG Stuttgart
(BLZ 600 800 00) Kto.-Nr. 9 010 051 00
IBAN: DE84 6008 0000 0901 00 51 00
Landesbank Baden-Württemberg
(BLZ 600 501 01) Kto.-Nr. 2 019 525

Vorsitzender des Aufsichtsrates:
Dipl.- Kfm. Klaus Schmidt
Geschäftsführer:
Dipl.- Ing. Clemens Klinke
Dipl.- Ing. Werner von Hebel
Dipl.- Kfm. Wolfgang Linsemaier
Dr.- Ing. Gerd Neumann

TENSIONMASTER



ZERTIFIKAT

AG70/11068/2008-18574-10

F. Hesterberg & Söhne

D-58256 Ennepetal

HESTAL-TensionMaster-Planenspanner mit Schlitz- und Vierkantwelle für Schiebepanenspannwellen bis zu 3.000 mm, gemäß HESTAL-Konstruktionsmatrix AG70/11068/2008-18574-10, erfüllen die derzeit geltenden Anforderungen und Regeln der Technik zur Nutzfahrzeugaufbaustabilität und zur Ladungssicherung, VDI 2700, DIN EN 12642 Code L und Code XL Anhang A und B und DAIMLER Richtlinie DE-RL. 9.5

D-01998 Klettwitz, 12. September 2008



Dipl.- Ing. Matthias STENAU
DEKRA Automobil GmbH
Technology-Center
Senftenberger Strasse 30
D-01998 Klettwitz

DEKRA Automobil GmbH
Handwerkstraße 15
D-70565 Stuttgart
Telefon 00 49 / 7 11 / 78 61-0
Telefax 00 49 / 7 11 / 78 61-22 40
www.dekra.com

Sitz Stuttgart, Amtsgericht Stuttgart,
HRB-Nr. 21039
Ust.-ID-Nr. DE 811 297 970
Steuer-Nr.: 99015/01322
Bankverbindung:
Dresdner Bank AG Stuttgart
(BLZ 600 800 00) Kto.-Nr. 9 010 051 00
IBAN: DE84 6008 0000 0901 00 51 00
Landesbank Baden-Württemberg
(BLZ 600 501 01) Kto.-Nr. 2 019 525

Vorsitzender des Aufsichtsrates:
Dipl.- Kfm. Klaus Schmidt
Geschäftsführer:
Dipl.- Ing. Clemens Klinke
Dipl.- Ing. Werner von Hebel
Dipl.- Kfm. Wolfgang Linsemaier
Dr.- Ing. Gerd Neumann

VARIOMASTER



ZERTIFIKAT

AG70/11068/2008-18574-1

HESTAL F. Hesterberg&Söhne
D-58256 Ennepetal

HESTAL-Vario Master-Schieberungen vom Typ 900, 902 und 903 Code L bis zu 3.000 mm, erfüllen die derzeit geltenden Anforderungen und Regeln der Technik zur Nutzfahrzeugaufbaustabilität und zur Ladungssicherung, gemäß dem DEKRA-Rungenanforderungsprofil[®], den Richtlinien VDI 2700 und 2700 Blatt 3, den Normen DIN-EN 12195-1, DIN EN 12642 Code L und Code XL Anhang A und B, sowie der DAIMLER Richtlinie DE-RL. 9.5

D-01998 Klettwitz, 25. Januar 2008



Dipl.- Ing. Matthias STENAU
DEKRA Automobil GmbH
Technology-Center
Senftenberger Strasse 30
D-01998 Klettwitz

DEKRA Automobil GmbH
Handwerksstraße 15
D-70565 Stuttgart
Telefon 00 49 / 7 11 / 78 61-0
Telefax 00 49 / 7 11 / 78 61-22 40
www.dekra.com

Sitz Stuttgart, Amtsgericht Stuttgart,
HRB-Nr. 21039
Ust.-ID-Nr. DE 811 297 970
Steuer-Nr.. 99015/01322
Bankverbindung:
Dresdner Bank AG Stuttgart
(BLZ 600 800 00) Kto.-Nr. 9 010 051 00
IBAN: DE84 6008 0000 0901 00 51 00
Landesbank Baden-Württemberg
(BLZ 600 501 01) Kto.-Nr. 2 019 525

Vorsitzender des Aufsichtsrates:
Dipl. - Kfm. Klaus Schmidt
Geschäftsführer:
Dipl.- Ing. Clemens Klinke
Dipl.- Ing. Werner von Hebel
Dipl.- Kfm. Wolfgang Linsemaier
Dr.- Ing. Gerd Neumann

VARIOMASTER



ZERTIFIKAT

AG70/11068/2008-18574-2

**HESTAL F. Hesterberg&Söhne
D-58256 Ennepetal**

HESTAL-Vario Master-Schieberungen vom Typ 901 und 904 Code XL bis zu 3.000 mm, erfüllen die derzeit geltenden Anforderungen und Regeln der Technik zur Nutzfahrzeugaufbaustabilität und zur Ladungssicherung, gemäß dem DEKRA-Rungenanforderungsprofil®, den Richtlinien VDI 2700 und 2700 Blatt 3, den Normen DIN-EN 12195-1, DIN EN 12642 Code L und Code XL Anhang A und B, sowie der DAIMLER Richtlinie DE-RL. 9.5

D-01998 Klettwitz, 25. Januar 2008



Dipl.- Ing. Matthias STENAU
DEKRA Automobil GmbH
Technology-Center
Senftenberger Strasse 30
D-01998 Klettwitz

DEKRA Automobil GmbH
Handwerkstraße 15
D-70565 Stuttgart
Telefon 00 49 / 7 11 / 78 61-0
Telefax 00 49 / 7 11 / 78 61-22 40
www.dekra.com

Sitz Stuttgart, Amtsgericht Stuttgart,
HRB-Nr. 21039
Ust.-ID-Nr. DE 811 297 970
Steuer-Nr. 99015/01322
Bankverbindung:
Dresdner Bank AG Stuttgart
(BLZ 600 800 00) Kto.-Nr. 9 010 051 00
IBAN: DE84 6008 0000 0901 00 51 00
Landesbank Baden-Württemberg
(BLZ 600 501 01) Kto.-Nr. 2 019 525

Vorsitzender des Aufsichtsrates:
Dipl.- Kfm. Klaus Schmidt
Geschäftsführer:
Dipl.- Ing. Clemens Klinke
Dipl.- Ing. Werner von Hebel
Dipl.- Kfm. Wolfgang Linsemaier
Dr.- Ing. Gerd Neumann

LASHING RINGS

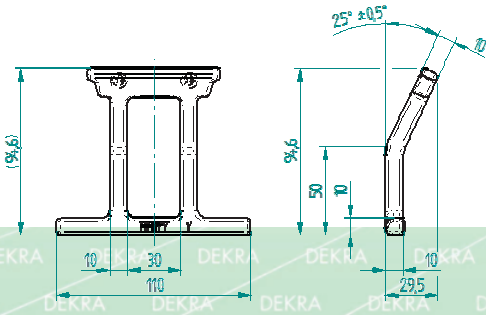

	
DEKRA Automobil GmbH 1 von 2	
Niederlassung Bielefeld, FB: Fahrzeugtechnik / Verkehrsunfallanalyse / Ladegutsicherung Otto-Brenner-Str. 168, D-33604 Bielefeld, Tel.: 00 49 / 521 / 2 99 05 – 28, Fax: - 70 E-Mail: thorsten.ludwig@dekra.com	
DEKRA Automobil GmbH Otto-Brenner-Str. 168 D-33604 Bielefeld DEKRA Automobil GmbH Otto-Brenner-Str. 168 D-33604 Bielefeld	
F. HESTERBERG & SÖHNE GMBH & CO. KG Heilenbecker Straße 50-60 D-58256 Ennepetal	Tel.: 02333 / 794 – 191 Fax: 02333 / 794 – 112 www.hestal.de
Von: Thorsten Ludwig 00 49 / 178 / 8 63 89 39	Bielefeld, 07.05.2014
DEKRA Zertifikat 313/14162/702073/1815325242-1 F. HESTERBERG & SÖHNE GMBH & CO. KG Zurrpunkt Typ 6.620.001.20	
DEKRA Zertifikat 313/14162/702073/1815325242-1 für die Übereinstimmung des Zurrbügels Typ 6.620.001.20 Stand 27.09.2013 nach DEKRA Dokumentationsstand vom 03.02.2014 in Verbindung mit Bodengruppe nach F. HESTERBERG & SÖHNE GMBH & CO. KG Zeichnungsnummer 6.630.001.00 Stand 14.04.2014 als zusätzliches Ladegutsicherungsmittel nach den anerkannten Richtlinien und Regeln der Technik zur Ladegutsicherung. Hiermit bestätigen wir der F. HESTERBERG & SÖHNE GMBH & CO. KG, dass in den DEKRA Versuchsreihen BI13/11/27-4 vom 27.11.2013 und BI14/02/03-2 vom 03.02.2014 getestete Kombination von Zurrbügel in Verbindung mit Bodenrahmen den Anforderungen der DIN EN 12640 sowie den derzeit gültigen Anforderungen und Regeln der Technik zur Ladegutsicherung als zusätzliches Ladegutsicherungsmittel nach DIN EN 12195 und Zurrpunkt nach DIN EN 12640 entspricht und diese erfüllt.	
Normen und Richtlinien:	
→ DIN EN 12640:	Zurr- und Anschlagpunkte auf Nutzfahrzeuge
F. HESTERBERG & SÖHNE GMBH & CO. KG Zurrpunkt Spezifikation vom 03.02.2014:	
Ausführung:	F. HESTERBERG & SÖHNE GMBH & CO. KG Bodenrahmenprofil mit Zurrpunkt
Zurrbügel:	Zurrbügel nach DEKRA Dokumentationsstand vom 03.02.2014 und F. HESTERBERG & SÖHNE GMBH & CO. KG Zeichnungsnummer 6.620.001.20 Stand 27.09.2013 in Kombination mit Halterung nach Zeichnungsnummer 6.620.001.21a Stand 27.09.2013.
	
-2-	

LASHING RINGS

Seite 2 von 2

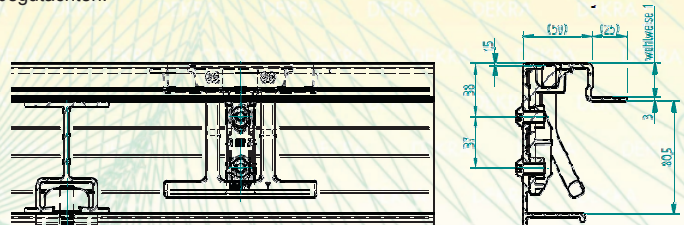

DEKRA Zertifikat 313/14162/702073/1815325242-1
F. HESTERBERG & SÖHNE GMBH & CO. KG
 Zurrpunkt Typ 6.620.001.20

Bodenrahmenprofil und Zurrpunktanbindung:	<p>Das Bodenrahmenprofil nach Zeichnungsnummer 6.620.001.09 oder 6.620.001.10 muss nach F. HESTERBERG & SÖHNE GMBH & CO. KG Vorgaben mit den Querträgern verbunden werden. Die Querträger sowie die Bodenrahmenprofilanbindung müssen den Stabilitätskriterien der DEKRA Versuche vom 27.11.2013 und 03.02.2014 entsprechen. Die Bodengruppe ist nach F. HESTERBERG & SÖHNE GMBH & CO. KG Zeichnungsnummer 6.630.001.00 Stand 14.04.2014 auszulegen. Alternativ können Bodengruppen und Bodenrahmenprofile mit identischem Stabilitätsnachweis eingesetzt werden. Diese sind auf Grundlage der DIN EN 12640 gesondert zu begutachten.</p>
	
Prüfkraft:	Soll: $1,25 \times LC \text{ [daN]} = 1,25 \times 1.962 \text{ [daN]} = 2.453,5 \text{ [daN]}$. Dies entspricht einer nutzbaren Zurrpunktbelastbarkeit nach DIN EN 12640 von 2.000 [kg]. Leichte plastische Verformung ohne Beeinträchtigung der Funktionalität.
Prüfung:	Zugprüfung in Y-Richtung, nach DIN-EN 12640, in Winkelstellungen 0°- 60° aus der Vertikalen mit einem geeigneten Sicherungsmittel gemäß DIN EN 12195-1 und DIN EN 12640.
Einsatzgebiet:	Als Zurrpunkt im Bodenrahmenprofil nach DIN EN 12640.
Hinweise/Auflagen:	Wir weisen ausdrücklich darauf hin, dass dieses Zertifikat nur für die vorgestellte und zertifizierte Bauform und Ausführung gilt. Sie erlischt nach Inkrafttreten neuer gesetzlicher Bestimmungen oder Änderungen wesentlicher Bestandteile der Zurrpunktconfiguration. Die zertifizierte Zurrpunktconfiguration ist analog zur Richtlinie VDI 2700 Blatt 3.1 in regelmäßigen Abständen spätestens jedoch jährlich, beispielsweise durch DEKRA Automobil GmbH, zum Zeitpunkt der Fahrzeughauptuntersuchung gemäß § 29 StVZO, einer Überprüfung durch den Hersteller oder durch ihn autorisierte Personen zu unterziehen. Instandsetzungen und Veränderungen sind nur durch den Hersteller oder durch ihn autorisierte Betriebe zulässig;
<p>Die Firma F. HESTERBERG & SÖHNE GMBH & CO. KG bestätigt mit ihrer Unterschrift, dass die Zurrpunktconfiguration dem DEKRA Dokumentationsstand vom 27.04.2013 sowie 03.02.2014 entspricht und die gleiche Stabilität nach DIN EN 12640 aufweist wie die in den Versuchsreihen B13/11/27-4 vom 27.11.2013 und B114/02/03-2 vom 03.02.2014 getesteten Zurrpunktconfiguration.</p>	
<p>DEKRA Sachverständiger:</p> <div style="text-align: center;">  Dipl.-Ing. (FH) Thorsten Ludwig </div>	<p>Komponentennummer:.....</p> <p>F. HESTERBERG & SÖHNE GMBH & CO. KG D-58256 Ennepetal</p>

ORDER NO.	PAGE	ORDER NO.	PAGE	ORDER NO.	PAGE	ORDER NO.	PAGE
6.011.059.99	160	6.020.752.00	108	6.021.634.00	117	6.040.031.00	120
6.020.047.00	163	6.020.753.00	108	6.021.635.00	117	6.040.032.00	120
6.020.048.00	163	6.020.780.00	108	6.021.636.00	119	6.040.079.00	159
6.020.120.00	163	6.020.781.00	108	6.021.637.00	119	6.040.080.00	159
6.020.124.00	168	6.020.799.95	110	6.021.668.00	108	6.060.013.00	121
6.020.127.00	168	6.020.800.95	110	6.021.669.00	108	6.060.233.00	126
6.020.128.00	168	6.020.803.95	110	6.021.672.00	113	6.060.250.00	123
6.020.142.00	160	6.020.804.95	110	6.021.673.00	113	6.060.258.00	126
6.020.143.00	160	6.020.807.95	110	6.021.674.00	113	6.060.261.00	123
6.020.167.00	161	6.020.808.95	110	6.021.675.00	113	6.060.320.00	123
6.020.168.00	161	6.020.811.95	110	6.021.676.00	113	6.070.025.01	150
6.020.265.00	168	6.020.812.95	110	6.021.677.00	113	6.070.027.01	148
6.020.285.00	168	6.020.815.00	108	6.021.679.00	116	6.071.129.00	126
6.020.286.00	168	6.020.816.00	108	6.021.680.00	116	6.071.137.00	126
6.020.299.00	166	6.020.853.00	108	6.021.685.00	116	6.071.137.99	123
6.020.300.00	166	6.020.854.00	108	6.021.686.00	116	6.071.146.99	108
6.020.302.00	166	6.020.858.00	111	6.021.691.00	116	6.071.147.99	108
6.020.303.00	166	6.020.859.00	111	6.021.692.00	116	6.071.156.10	89
6.020.304.00	166	6.020.862.00	111	6.021.697.00	116	6.071.156.10	95
6.020.305.00	166	6.020.863.00	111	6.021.698.00	116	6.071.156.99	88
6.020.306.00	166	6.020.882.00	108	6.021.703.00	116	6.071.156.99	95
6.020.307.00	166	6.020.883.00	108	6.021.704.00	116	6.071.157.00	89
6.020.308.00	166	6.020.920.00	113	6.021.709.00	117	6.071.157.00	95
6.020.309.00	166	6.020.921.00	113	6.021.710.00	116	6.071.158.00	88
6.020.310.00	166	6.020.922.00	113	6.021.716.00	117	6.071.159.10	88
6.020.311.00	166	6.020.923.00	113	6.021.721.00	117	6.071.159.99	86
6.020.312.00	166	6.020.924.00	113	6.021.722.00	117	6.071.160.99	86
6.020.313.00	166	6.020.925.00	113	6.021.727.00	117	6.071.164.99	88
6.020.314.00	166	6.021.577.00	108	6.021.728.00	117	6.071.165.99	86
6.020.315.00	166	6.021.578.00	108	6.030.052.00	164	6.071.166.00	87
6.020.383.00	163	6.021.579.00	108	6.030.075.99	163	6.071.167.99	85
6.020.384.00	163	6.021.580.00	108	6.030.077.99	163	6.080.460.00	70
6.020.390.00	163	6.021.581.00	108	6.030.077.99	163	6.080.461.00	76
6.020.706.00	164	6.021.582.00	108	6.030.018.00	163	6.080.462.00	72
6.020.709.00	164	6.021.583.00	108	6.030.089.99	163	6.080.463.00	78
6.020.710.00	164	6.021.584.00	108	6.030.090.99	161	6.080.464.00	70
6.020.740.00	108	6.021.600.00	108	6.030.097.01	166	6.080.465.00	76
6.020.741.00	108	6.021.601.00	108	6.031.078.00	168	6.080.466.00	72
6.020.748.00	108	6.021.630.00	116	6.031.123.99	168	6.080.467.00	78
6.020.749.00	108	6.021.631.00	116	6.031.124.99	168	6.080.468.00	70
6.020.750.00	108	6.021.632.00	117	6.031.132.99	166	6.080.469.00	76
6.020.751.00	108	6.021.633.00	117	6.031.132.99	168	6.080.470.00	72

ORDER NO.	SEITE	ORDER NO.	SEITE	ORDER NO.	SEITE	ORDER NO.	SEITE
6.080.471.00	78	6.080.529.00	93	6.090.116.68	30	6.090.284.51	35
6.080.472.00	70	6.080.530.00	93	6.090.121.00	30	6.100.198.01	149
6.080.473.00	76	6.080.531.00	93	6.090.122.07	67	6.100.212.00	141
6.080.474.00	72	6.080.532.00	93	6.090.151.98	29	6.100.212.10	149
6.080.475.00	78	6.080.533.00	93	6.090.151.99	29	6.100.212.11	149
6.080.484.00	74	6.080.534.00	93	6.090.153.00	28	6.100.212.15	147
6.080.485.00	74	6.080.535.00	93	6.090.154.00	27	6.100.212.16	147
6.080.486.00	80	6.080.538.00	70	6.090.155.00	32	6.100.212.20	147
6.080.487.00	80	6.080.539.00	76	6.090.155.25	38	6.100.212.55	152
6.080.490.00	82	6.080.550.00	74	6.090.156.00	33	6.100.213.55	152
6.080.491.00	82	6.080.551.00	74	6.090.157.00	28	6.100.214.55	153
6.080.492.00	74	6.080.552.00	80	6.090.158.00	29	6.100.215.00	141
6.080.493.00	74	6.080.553.00	80	6.090.177.00	33	6.100.216.55	152
6.080.494.00	80	6.080.574.00	90	6.090.182.01	85	6.100.226.55	152
6.080.495.00	80	6.080.575.00	90	6.090.201.99	38	6.100.236.55	153
6.080.498.00	82	6.080.588.00	98	6.090.201.99	86	6.140.828.00	145
6.080.499.00	82	6.080.589.00	98	6.090.203.50	84	6.140.828.00	155
6.080.500.00	74	6.080.590.00	98	6.090.203.99	84	6.141.094.01	145
6.080.501.00	74	6.080.591.00	98	6.090.204.99	84	6.141.094.01	151
6.080.502.00	80	6.080.592.00	98	6.090.211.01	96	6.141.094.02	145
6.080.503.00	80	6.080.593.00	102	6.090.211.02	96	6.141.094.02	151
6.080.506.00	82	6.080.594.00	102	6.090.219.10	85	6.141.121.27	45
6.080.507.00	82	6.080.595.00	102	6.090.219.20	85	6.141.121.27	61
6.080.508.00	74	6.080.596.00	102	6.090.219.30	85	6.141.123.97	43
6.080.509.00	74	6.080.597.00	102	6.090.219.40	85	6.141.200.99	18
6.080.510.00	80	6.080.598.00	102	6.90.220.98	29	6.141.201.97	18
6.080.511.00	80	6.080.599.00	102	6.090.220.99	29	6.141.201.98	18
6.080.514.00	82	6.080.600.00	102	6.090.226.00	35	6.141.202.98	18
6.080.515.00	82	6.080.601.00	102	6.090.227.00	86	6.141.203.98	18
6.080.516.00	90	6.080.602.00	102	6.090.227.99	38	6.141.204.98	18
6.080.517.00	90	6.080.603.00	100	6.090.237.00	38	6.141.220.98	43
6.080.518.00	90	6.080.604.00	100	6.090.237.55	40	6.141.220.99	44
6.080.519.00	90	6.080.605.00	100	6.090.238.00	39	6.141.230.40	61
6.080.520.00	90	6.080.606.00	100	6.090.239.00	40	6.141.230.51	61
6.080.521.00	90	6.080.607.00	104	6.090.240.00	39	6.141.230.52	61
6.080.522.00	90	6.080.608.00	104	6.090.240.55	41	6.141.230.53	61
6.080.523.00	90	6.080.609.00	104	6.090.244.00	39	6.141.230.54	61
6.080.524.00	90	6.080.610.00	104	6.090.245.00	38	6.141.230.55	61
6.080.525.00	90	6.080.611.00	104	6.090.245.55	40	6.141.230.56	61
6.080.526.00	93	6.080.612.00	104	6.090.246.00	39	6.141.230.57	61
6.080.527.00	93	6.080.613.00	104	6.090.247.00	40	6.141.230.58	61
6.080.528.00	93	6.080.614.00	104	6.090.248.00	35	6.141.230.59	61

ORDER NO.	PAGE	ORDER NO.	PAGE	ORDER NO.	PAGE	ORDER NO.	PAGE
6.141.230.60	61	6.141.703.15	149	6.500.011.26	66	6.600.001.06	133
6.141.234.50	66	6.141.703.16	143	6.500.011.60	65	6.600.001.08	133
6.141.234.52	66	6.141.703.16	149	6.500.011.61	65	6.600.001.09	134
6.141.234.55	66	6.141.703.17	143	6.500.011.62	65	6.600.001.10	134
6.141.234.57	66	6.141.703.17	147	6.500.011.63	65	6.600.001.11	133
6.141.672.99	45	6.141.704.10	144	6.500.011.64	65	6.600.001.12	133
6.141.673.99	45	6.141.704.11	144	6.500.011.65	65	6.600.001.13	132
6.141.680.00	62	6.141.704.12	144	6.500.011.66	65	6.600.001.14	132
6.141.687.99	45	6.141.704.19	148	6.500.011.67	65	6.600.001.15	132
6.141.695.98	44	6.141.704.20	148	6.500.050.02	63	6.600.001.16	132
6.141.695.99	45	6.141.704.60	144	6.500.050.03	63	6.600.001.17	136
6.141.702.00	141	6.141.704.60	148	6.500.060.01	63	6.600.001.18	136
6.141.702.10	145	6.141.704.61	144	6.500.060.02	63	6.600.001.19	136
6.141.702.10	155	6.141.704.61	148	6.500.060.03	63	6.600.001.20	137
6.141.702.11	145	6.141.705.50/98	44	6.500.060.16	63	6.600.001.22	137
6.141.702.11	155	6.141.719.00	43	6.500.070.01	62	6.600.001.24	133
6.141.702.12	145	6.141.719.00	61	6.500.080.00	66	6.600.001.27	135
6.141.702.13	145	6.141.725.00	141	6.500.107.00	59	6.600.001.28	138
6.141.702.13	155	6.141.725.00	154	6.500.108.00	59	6.600.001.30	138
6.141.702.14	145	6.141.725.55	155	6.500.109.00	59	6.600.001.31	138
6.141.702.14	146	6.141.726.00	141	6.510.354.99	129	6.600.001.35	135
6.141.702.14	155	6.141.726.00	141	6.510.363.00	129	6.600.001.36	132
6.141.702.15	145	6.141.726.00	154	6.510.409.99	128	6.600.001.37	135
6.141.702.15	155	6.141.726.55	155	6.510.410.99	128	6.600.001.38	133
6.141.702.17	145	6.141.735...744.55	155	6.510.418.99	128	6.600.001.39	133
6.141.702.17	155	6.500.001.26	63	6.510.419.99	128	6.600.001.40	132
6.141.702.18 (M10)	145	6.500.001.28	64	6.510.430.99	129	6.600.001.41	137
6.141.702.19 (M10)	145	6.500.001.29	64	6.510.469.98	130	6.600.001.45	138
6.141.702.55	155	6.500.001.38	62	6.510.469.99	130	6.660.001.10	16
6.141.702.56	155	6.500.001.39	62	6.510.470.99	130	6.800.174.00	20
6.141.702.60	145	6.500.007.00	64	6.510.481.98	130	6.800.174.09	26
6.141.702.60	155	6.500.008.00	64	6.510.481.99	130	6.800.174.09	37
6.141.702.61	145	6.500.008.21	64	6.510.533.99	130	6.800.174.10	26
6.141.702.61	155	6.500.008.22	64	6.510.595.97	130	6.800.174.10	37
6.141.702.62	145	6.500.008.23	64	6.510.595.98	130	6.800.174.12	30
6.141.702.63	145	6.500.009.50	65	6.510.598.97	130	6.800.175.00	20
6.141.703.00	141	6.500.009.51	65	6.510.598.99	130	6.800.182.00	24
6.141.703.01	143	6.500.011.21	66	6.510.610.00	141	6.800.182.09	27
6.141.703.02	143	6.500.011.22	66	6.511.355.99	129	6.800.182.09	37
6.141.703.13	143	6.500.011.23	65	6.511.356.99	129	6.800.183.00	24
6.141.703.14	143	6.500.011.24	65	6.600.001.03	135	6.800.184.00	24
6.141.703.15	143	6.500.011.25	66	6.600.001.05	135	6.800.185.00	24

ORDER NO.	PAGE	ORDER NO.	PAGE
6.800.197.00	20	6.850.042.03	50
6.800.198.00	20	6.850.042.03	170
6.800.206.00	20	6.850.042.04	50
6.800.211.00	20	6.850.042.04	170
6.800.212.00	20	6.850.042.05	50
6.800.215.00	20	6.850.042.05	170
6.800.215.01	34	6.850.047.00	172
6.800.216.00	20	6.850.048.00	172
6.800.216.01	34	6.850.049.00	172
6.800.218.02	32	6.850.050.00	172
6.800.258.01	31	6.850.051.00	172
6.800.258.02	31	6.850.052.00	18
6.800.258.50	31	6.850.052.00	171
6.800.258.51	31	6.850.053.00	18
6.800.353.00	20	6.850.053.00	171
6.800.409.13	37	6.850.054.00	96
6.810.060.53	48	6.850.054.00	172
6.810.078.59	49	6.850.055.00	172
6.810.078.59	52	6.850.057.00	50
6.810.078.99	49	6.850.057.00	171
6.810.085.81	53	6.850.058.00	50
6.810.088.03	52	6.850.058.00	171
6.810.088.04	53		
6.810.088.20	52		
6.810.088.53	52		
6.810.090.00	51		
6.810.091.00	51		
6.810.092.00	51		
6.810.168.00	47		
6.810.168.00	47		
6.810.169.00	47		
6.810.169.00	47		
6.810.179.00	47		
6.810.179.00	47		
6.810.200.00	53		
6.850.035.00	169		
6.850.036.00	169		
6.850.038.00	169		
6.850.039.01	170		
6.850.039.02	170		
6.850.040.00	170		
6.850.041.00	169		

The brands of the BPW Group:



ERMAX®



HESTAL®



HESTAL – THE BRAND OF THE F. HESTERBERG & SÖHN GMBH & CO. KG

Heilenbecker Straße 50-60 • D-58256 Ennepetal • Tel. +49 (0)2333 794-0 • Fax +49 (0)2333 794-162
www.hestal.de • info@hestal.de

HESTAL 
LOCKS YOUR LOAD BEST

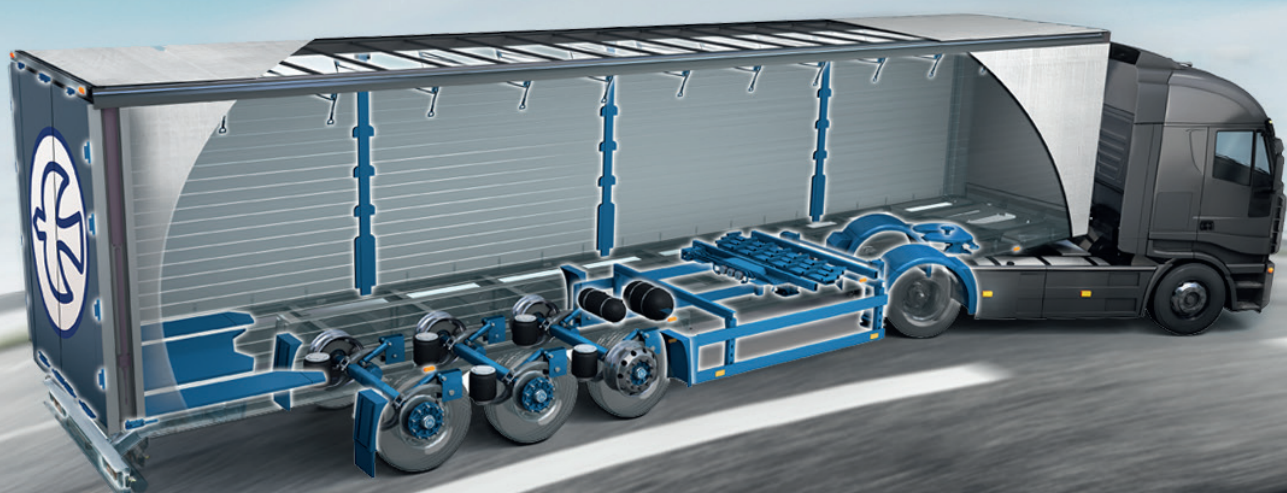

Truck and Trailer Kits

CONTENTS

BOX VAN SUBSTRUCTURE		
	Overview	195
	Individual components	196
FLATBED PLATEAU		
	Overview	199
	Individual components	201
ALUMINIUM DROP-SIDE		
	Overview	207
	Drop-side hinges 654N, 655N, 656N, 657	208
	Hestal Snap 25 profiles	211
	Hestal Snap 25 accessories	218
FLATBED SUPERSTRUCTURE		219
CURTAINSIDER SUPERSTRUCTURE		
	Overview	221
	Individual components	224
CONFIGURATION TEMPLATES		227
INDEX		231

OVERVIEW

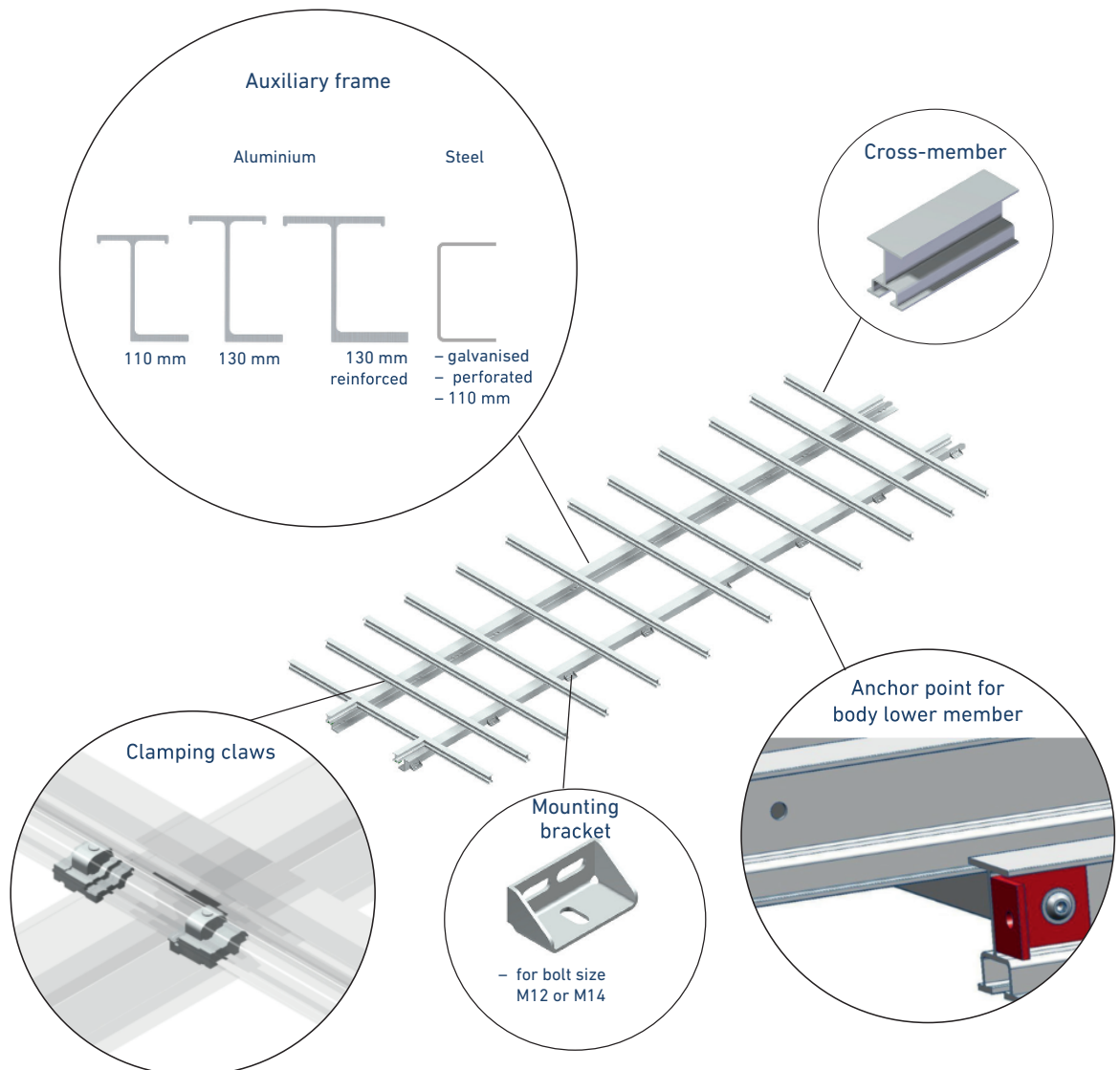

Field of application

Vehicle chassis for commercial vehicles up to 15 t gross vehicle weight.

Technology

- Weight saving thanks to aluminium body
 - Low body weight results in higher payload and reduced fuel consumption
- Ease of installation
 - Quick installation with clamps, bolted variant and preassembly
- Product variety / high degree of flexibility
 - Length up to 7200 mm and maximum overall width up to 2550 mm
 - Variable number of cross-members

INDIVIDUAL COMPONENTS

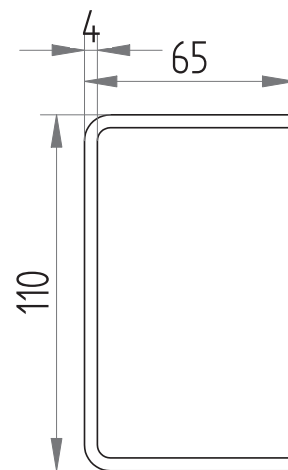
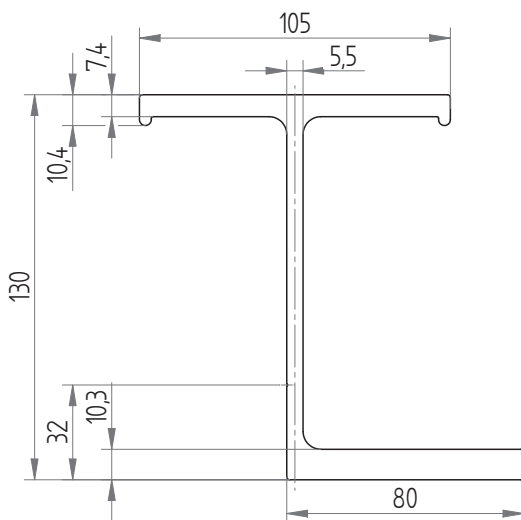
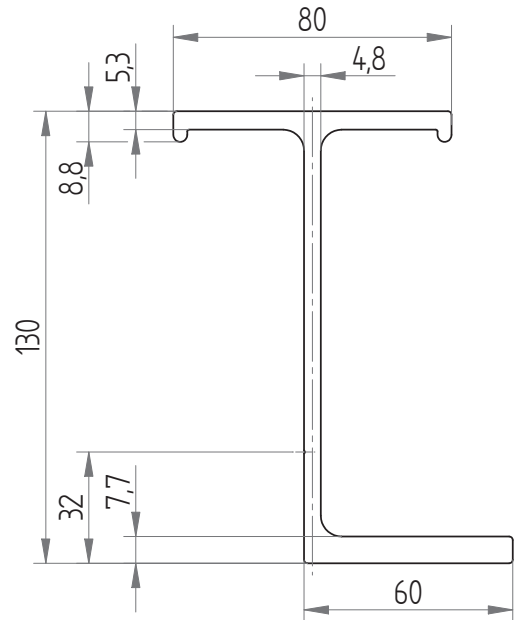
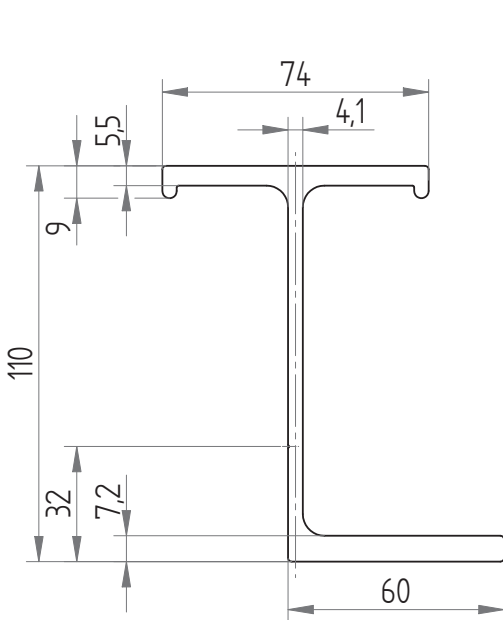

Description	Profile height	Weight	Order no.
Aluminium auxiliary frame profiles	110 mm	3.658 kg/m	6.620.001.00
Aluminium auxiliary frame profiles	130 mm	4.256 kg/m	6.620.001.01
Aluminium auxiliary frame profiles	130 mm reinforced	6.440 kg/m	6.620.001.02
Steel auxiliary frame profiles	110 mm	7.033 kg/m	6.620.001.03

*Subject to change | Date: July 2016

INDIVIDUAL COMPONENTS

Figure	Description	Order no.
	<p>Box body mounting bracket</p> <p>Contains: Box body mounting bracket 50 x 50 x 5 – 45 long Washer B 10.5 DIN 125 Fillister head screw with flange M10 x 25 Lock nut M10</p>	<p>6.620.014.70</p>
	<p>Shear plate</p> <p>Contains: Shear plate Long counterplate Hexagon head bolt with flange M12 x 35 Locking nut with flange M12</p>	<p>6.620.014.20</p>
	<p>Flatbed body mounting bracket</p> <p>Contains: Flatbed body mounting bracket Fillister head screw with flange M10 x 25 Lock nut M10 Washer B 10.5 DIN 125</p>	<p>6.620.014.80</p>
	<p>Clamping claws</p> <p>Contains: Hexagon head bolt M10 x 1 x 40 Washer B 10.5 DIN 125 Lock washer B10 DIN 127 Clamping claw 18 x 44 x 50 Sliding stone 100 mm</p>	<p>6.620.014.40</p>

*Subject to change | Date: July 2016

INDIVIDUAL COMPONENTS

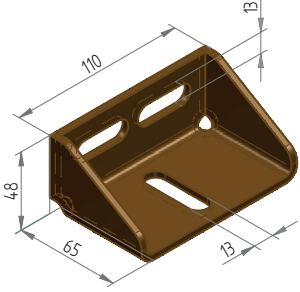
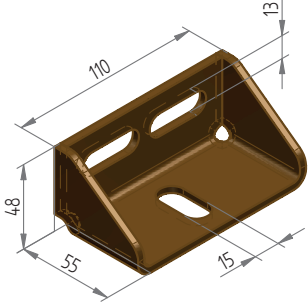
Figure	Description	Order no.
	<p>Mounting bracket size 1</p> <p>Contains: Counterplate Hexagon head bolt with flange M12 x 35 Locking nut M12</p>	<p>6.620.014.00</p>
	<p>Mounting bracket size 2</p> <p>Contains: Counterplate Hexagon head bolt with flange M12 x 35 Locking nut M12</p>	<p>6.620.014.10</p>

*Subject to change | Date: July 2016

OVERVIEW

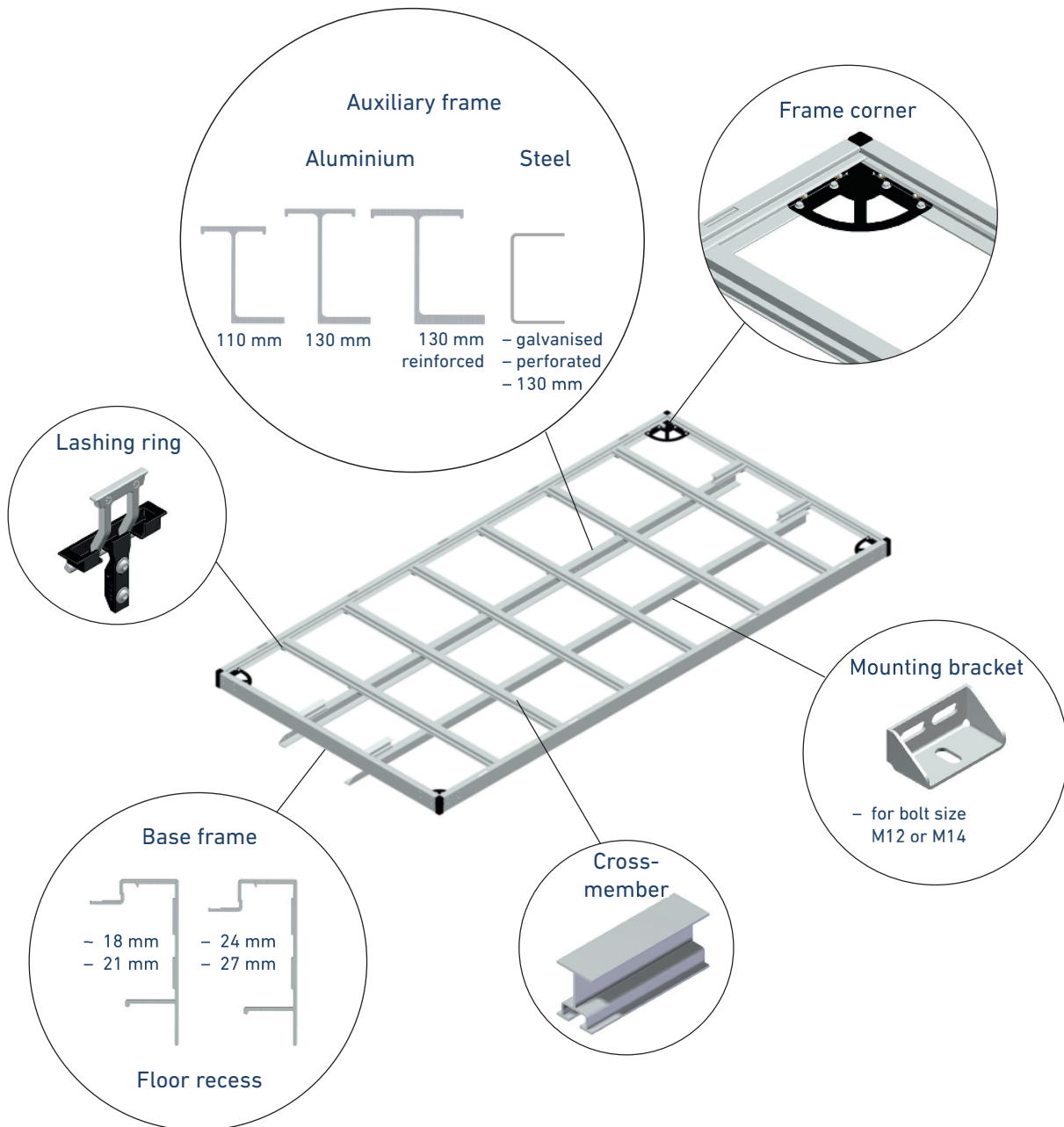

OVERVIEW

Field of application

For commercial vehicle up to 15 t gross vehicle weight.

Technology

- **Weight saving due to aluminium body**
 - Low body weight results in higher payload and reduced fuel consumption
- **Ease of installation**
 - Quick installation with clamps, bolted variant and preassembly
- **Product reliability**
 - Corrosion protection due to KTL coating of the steel parts
- **Product variety / high degree of flexibility**
 - Length up to 7200 mm and maximum overall width up to 2550 mm
 - Floor recess (18 mm, 21 mm, 24 mm, 27 mm)
 - Number of lashing points in accordance with DIN EN 12640
 - Variable number of cross-members
 - Crane superstructures possible

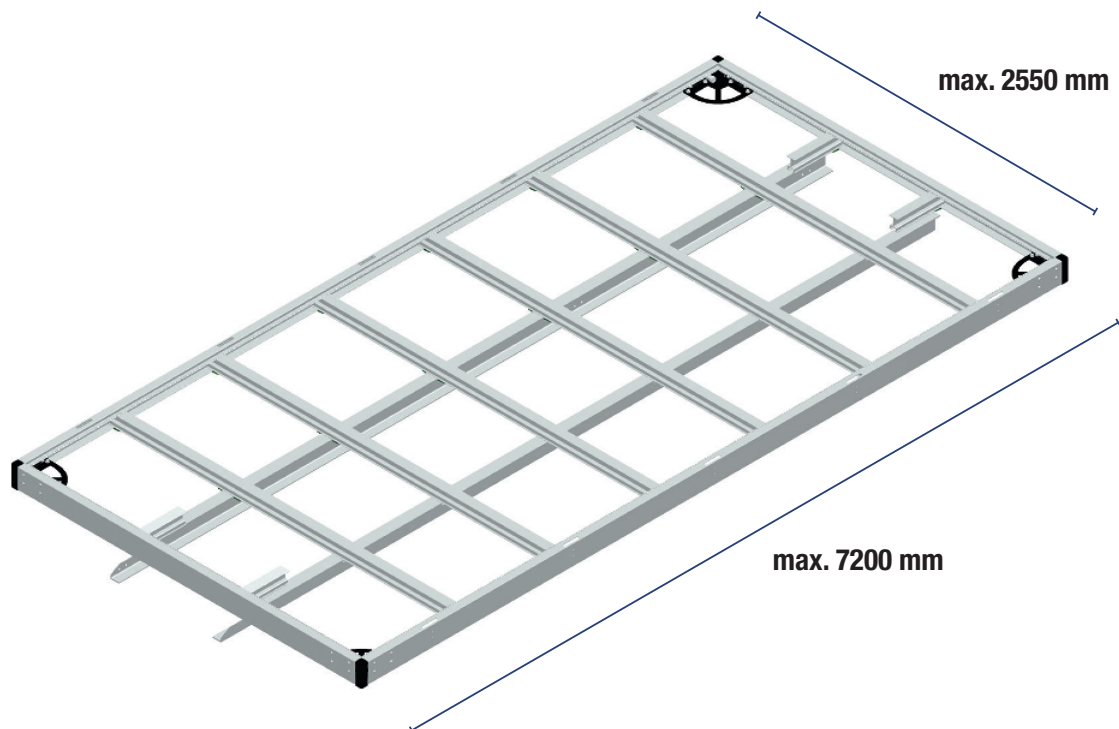

*Subject to change | Date: July 2016

INDIVIDUAL COMPONENTS

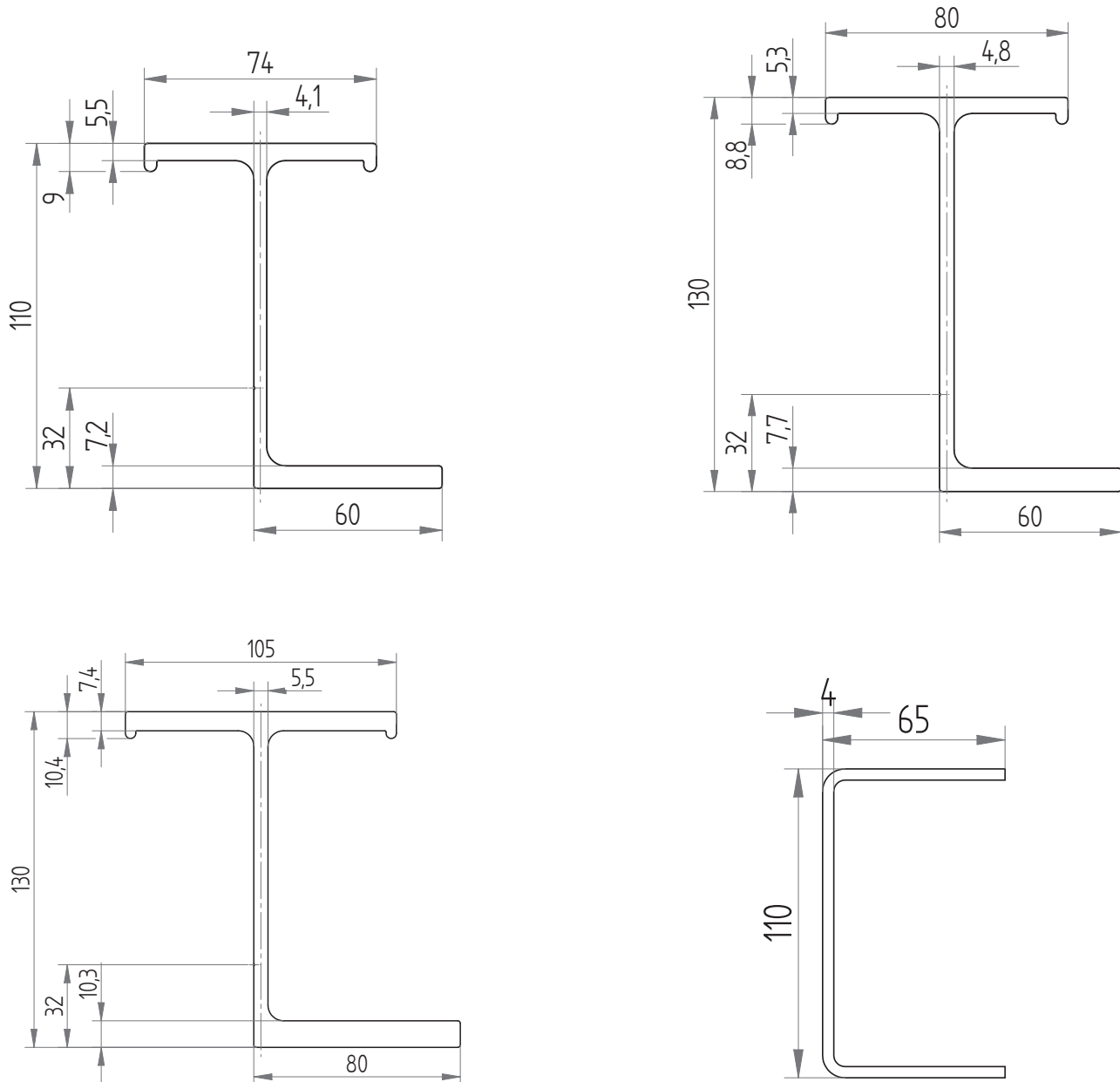

Description	Profile height	Weight	Order no.
Aluminium auxiliary frame profiles	110 mm	3.658 kg/m	6.620.001.00
Aluminium auxiliary frame profiles	130 mm	4.256 kg/m	6.620.001.01
Aluminium auxiliary frame profiles	130 mm reinforced	6,440 kg/m	6.620.001.02
Steel auxiliary frame profiles	110 mm	7.033 kg/m	6.620.001.03

*Subject to change | Date: July 2016

INDIVIDUAL COMPONENTS

Figure	Description	Order no.
	<p>Base frame connection</p> <p>Contains: Base frame connection Sliding stone 18 mm / 80 mm Hexagon head bolt M10 x 1 x 30 Washer B 10.5 DIN 125 Lock washer B10 DIN 127</p>	<p>6.620.014.30</p>
	<p>Cross-member clamping claw</p> <p>Contains: Hexagon head bolt M10 x 1 x 40 Washer B 10.5 DIN 125 Lock washer B10 DIN 127 Clamping claw Sliding stone 100 mm</p>	<p>6.620.014.40</p>

*Subject to change | Date: July 2016

INDIVIDUAL COMPONENTS

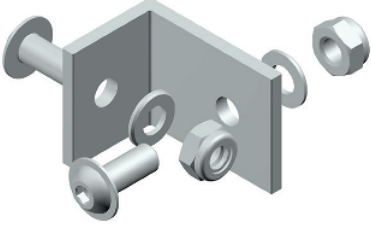
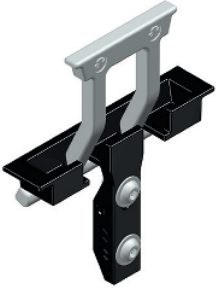
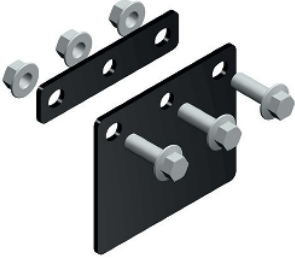
Figure	Description	Order no.
	<p>Flatbed body mounting bracket</p> <p>Contains: Flatbed body mounting bracket Fillister head screw with flange M10 Lock nut M10x25 Washer B 10.5 DIN 125</p>	<p>6.620.014.80</p>
	<p>Lashing ring</p> <p>Contains: Bracket for lashing ring Lashing ring Lock nut M8 Fillister head screw with flange M8x16 Tensile strength 2000 daN</p>	<p>6.620.014.90</p>
	<p>Shear plate</p> <p>Contains: Shear plate Long counterplate Hexagon head bolt with flange M12x35 Locking nut with flange M12</p>	<p>6.620.014.20</p>
	<p>Mounting bracket size 1</p> <p>Contains: Counterplate Hexagon head bolt with flange M12x35 Locking nut M12</p>	<p>6.620.014.00</p>

*Subject to change | Date: July 2016

INDIVIDUAL COMPONENTS

Figure	Description	Order no.
	<p>Mounting bracket size 2</p> <p>Contains: Counterplate Hexagon head bolt with flange M12 x 35 Locking nut M12</p>	<p>6.620.014.10</p>
	<p>Front frame corner for 802P</p> <p>Left Right</p>	<p>6.630.002.00 6.630.002.10</p>
	<p>Rear frame corner for SolidMaster rear pillars</p> <p>Left Right</p>	<p>6.630.002.20 6.630.002.30</p>
	<p>Frame corner for flatbed</p>	<p>6.620.012.00</p>

*Subject to change | Date: July 2016

INDIVIDUAL COMPONENTS

Figure	Description	Order no.
	<p>Cross-member profile</p>	<p>6.620.001.05</p>
	<p>Base frame profile 18/21 mm</p>	<p>6.620.001.09</p>
	<p>Base frame profile 24/27 mm</p>	<p>6.620.001.10</p>
	<p>Compensation profile</p>	<p>6.620.001.06</p>

*Subject to change | Date: July 2016

INDIVIDUAL COMPONENTS

Figure	Description	Order no.
	<p>Collision protection 40 mm</p>	<p>6.620.001.22</p>

*Subject to change | Date: July 2016

OVERVIEW

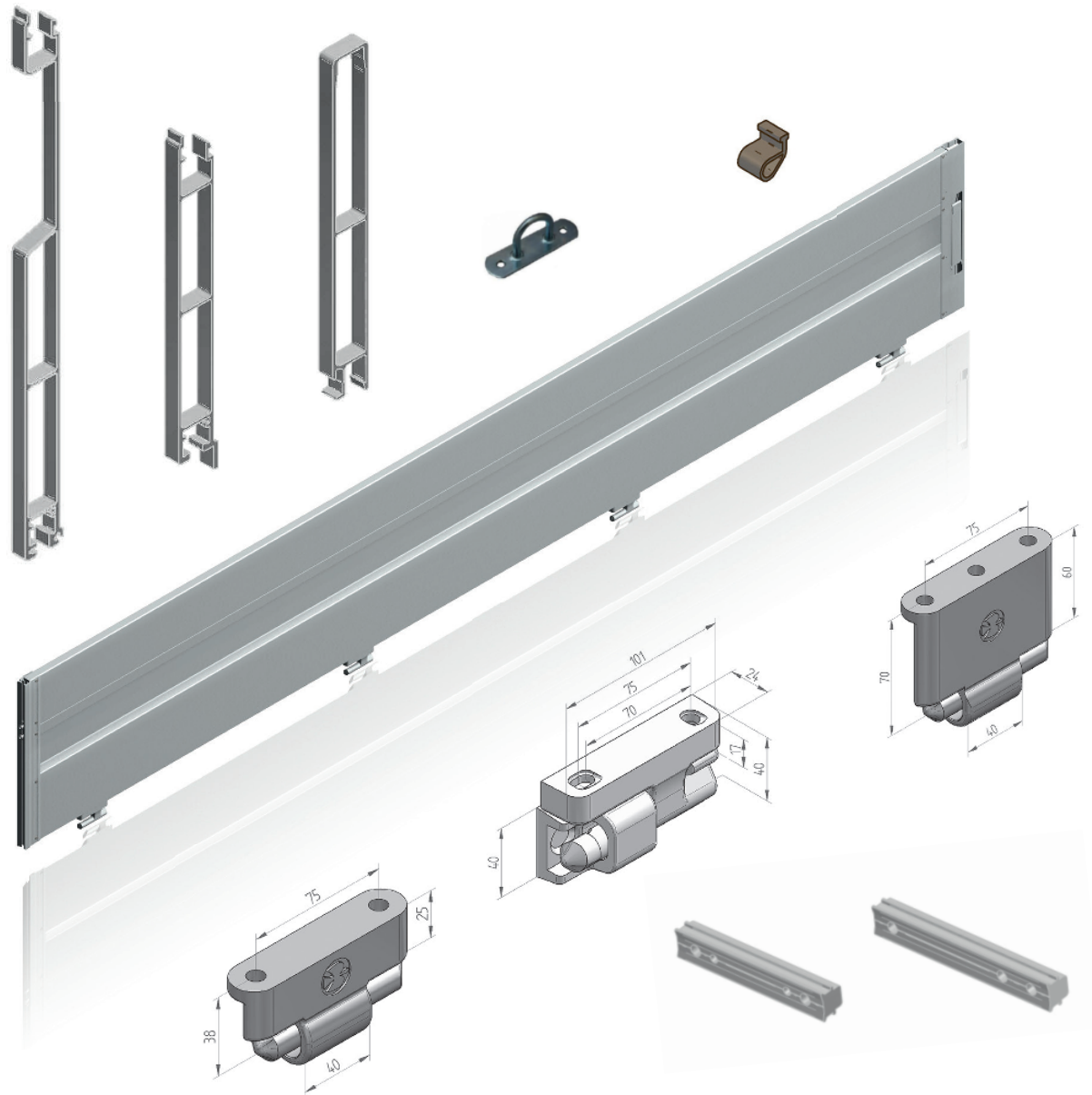

- Drop-side hinges 654N, 655N, 656N, 657
- HESTAL Snap 25 profiles
- HESTAL Snap 25 accessories

DROP-SIDE HINGE 654N

654N is a proven hinge for aluminium drop-sides (25 mm or 30 mm thick) satisfying customs requirements for medium-heavy and heavy flatbed superstructures.

Technology

- Positive-fit locking design principle prevents accidental opening of the drop-side
- The 654N hinge consists of bearing housing 6540N (which can be bolted or welded to the vehicle frame) and hinge bolt 6541N (is fastened to the drop-side)
- The hinge bolts can alternatively be ordered with M12 tie rod bore (which is special version available at additional charge)

Versions

Hinge bolt, electrogalvanised to FHS-TL 9.01

Bearing housing, raw or electrogalvanised to FHS-TL 9.01

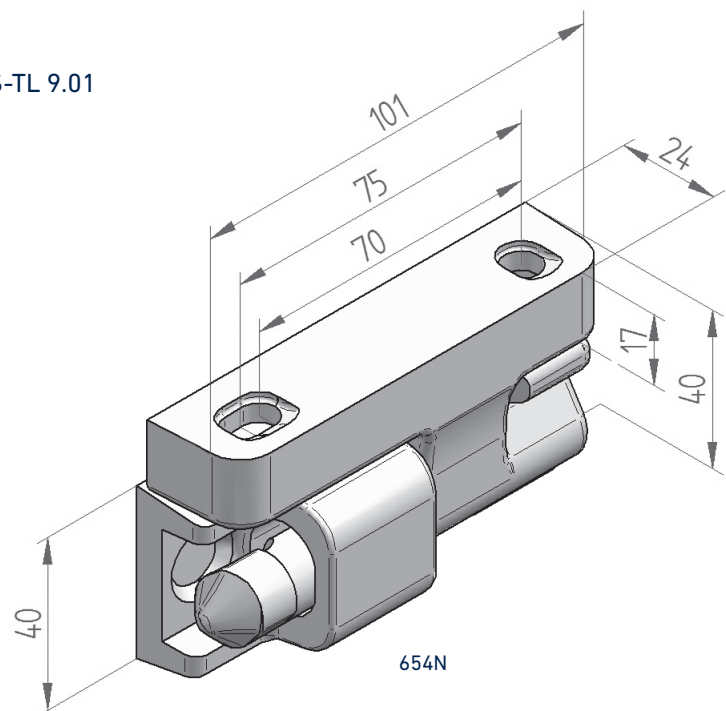

Type	Description	Weight	Order no.
6540N	Hinge bearing, raw, non-drilled	0.30 kg	6.510.409.99
65400N	Hinge bearing, galvanised	0.30 kg	6.510.418.99
6541N	Hinge bolt, galvanised	0.34 kg	6.510.410.99
6541N	Bolt with tie rod bore, galvanised	0.33 kg	6.510.419.99

*Subject to change | Date: July 2016

DROP-SIDE HINGE 655N, 656N

- 655N and 656N are proven hinges for aluminium drop-sides (25 mm thick) satisfying customs requirements for medium-heavy and heavy flatbed superstructures (hinge 656N and for swap bodies)
- The large pivot point distance of hinge 656N allows easy folding down of the drop-sides beyond the lateral extension protector

Technology

- Consists of non-galvanised welding bolt 6550N and galvanised pivot bearing 6552N
- The bolt is welded to the vehicle frame
- Pivot bearing is fastened to the drop-side
- Pivot bearing can alternatively be ordered with M12 tie rod bore (at additional charge)

Versions

Pivot bearing, electrogalvanised to FHS-TL 9.01

Welding bolt, raw or electrogalvanised to FHS-TL 9.01

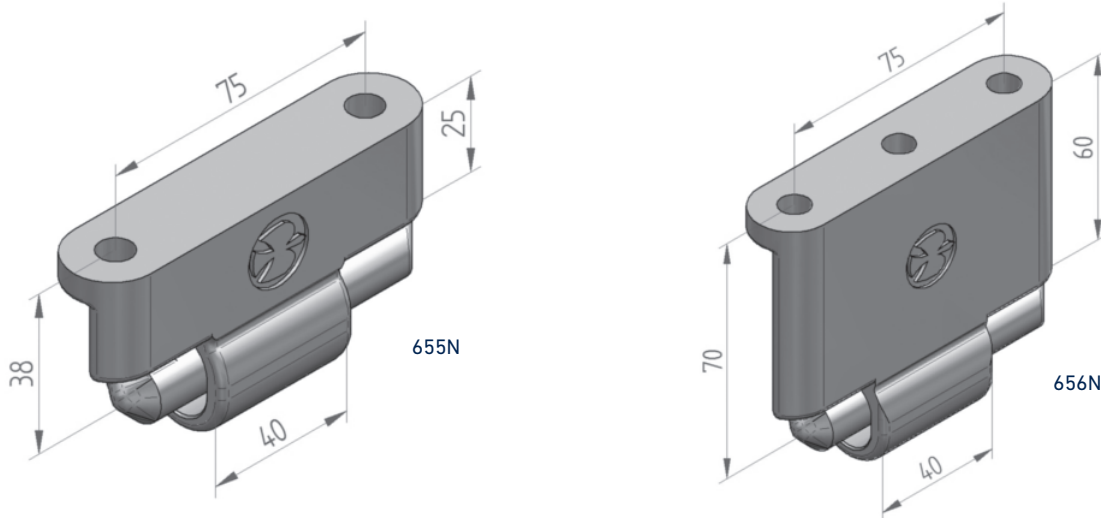

Type	Description	Weight	Order no.
6550N	Bolt right, raw	0.25 kg	6.511.355.99
6550N	Bolt left, raw	0.25 kg	6.511.356.99
6552N	Pivot bearing, galvanised	0.36 kg	6.510.354.99
6552N M12	Bearing with tie rod bore, galvanised	0.35 kg	6.510.363.00
6561N M12	Bearing with tie rod bore, galvanised	0.49 kg	6.510.430.99

*Subject to change | Date: July 2016

DROP-SIDE HINGE 657

- The drop-side hinge satisfying customs requirements is suitable for light flatbed superstructures and car trailers of all kinds
- For 25 mm drop-sides of steel and aluminium
- For outboard and inboard drop-sides
- Thanks to the compact design, the hinge 657 can be used on narrow outer frames (bolt-on, weld-on)

Advantages/benefits

- Positive-fit locking design principle satisfies customs requirements and prevents accidental opening of the drop-side
- The individual components can be combined and allow a wide variety of mounting variations
- Drop-side hinge 657/2 has a pivot point distance from the drop-side profile of 32 mm, hinge 657/5 a pivot point distance of 38 mm

Versions

Hinge bolt and bearing housing, electrogalvanised to FHS-TL 9.01 (further surfaces, such as hot-dip galvanised to FHS-TL 9.22 available on special order)

Bearing housing 6576 additionally KTL black coated to FHS-TL 9.13

Type	Description	Weight	Order no.
6570	Bearing housing, raw	0.13 kg	6.510.470.99
6572	Hinge bolt, galvanised	0.18 kg	6.510.469.99
6575	Hinge bolt, hot-dip galvanised	0.20 kg	6.510.598.99
6576	Bearing housing, KTL coated	0.13 kg	6.510.595.97
6576	Bearing housing, galvanised	0.13 kg	6.510.595.98
65700	Bearing housing, galvanised	0.11 kg	6.510.481.99
6572	Hinge bolt, raw	0.18 kg	6.510.469.98
65700	Bearing house, drilled	0.11 kg	6.510.481.98
65700	Bearing housing, galvanised	0.12 kg	6.510.533.99
6575	Hinge bolt, KTL coated	0.2 kg	6.510.598.97

*Subject to change | Date: July 2016

HESTAL SNAP 25

Field of application

For commercial vehicles up to 15 t gross vehicle weight in combination with an aluminium flatbed superstructure.

Technology

- Product reliability
 - Dekra-certified up to a payload of 10,7 t
 - Aluminium flatbed body in conjunction with certified body to DIN EN 12642 Code XL Annex A
- Product variety / high degree of flexibility
 - Drop-side height (400 mm, 500 mm, 600 mm, 800 mm, 1000 mm)
- Pillar variants (801 and 802)
 - Fastener variants (681S10, 710, 715, 720 ,810)
 - Hinge variants (654N, 655N, 657)
 - Hasp profile
 - Folding step
 - Surface finish in raw, anodised, powder primed and powder coated

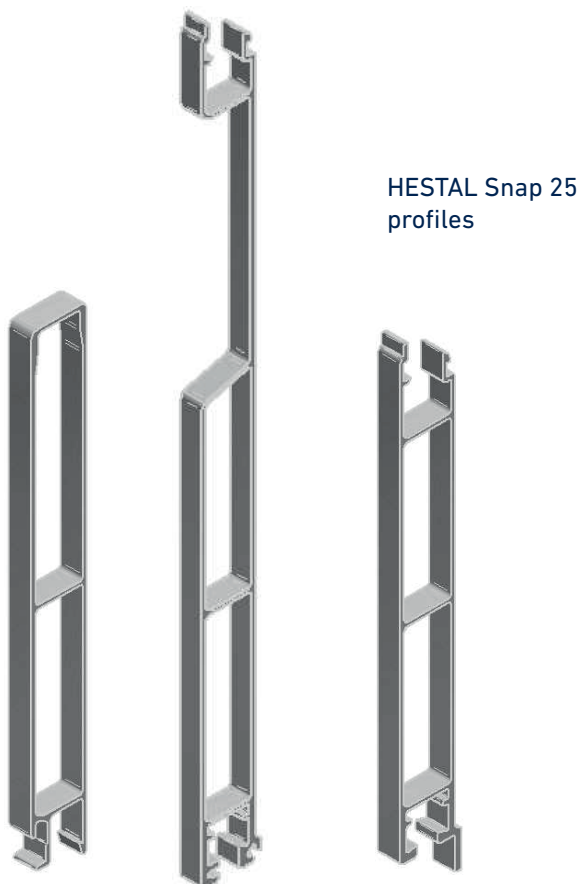

*Subject to change | Date: July 2016

HESTAL SNAP 25 – UPPER END PROFILES

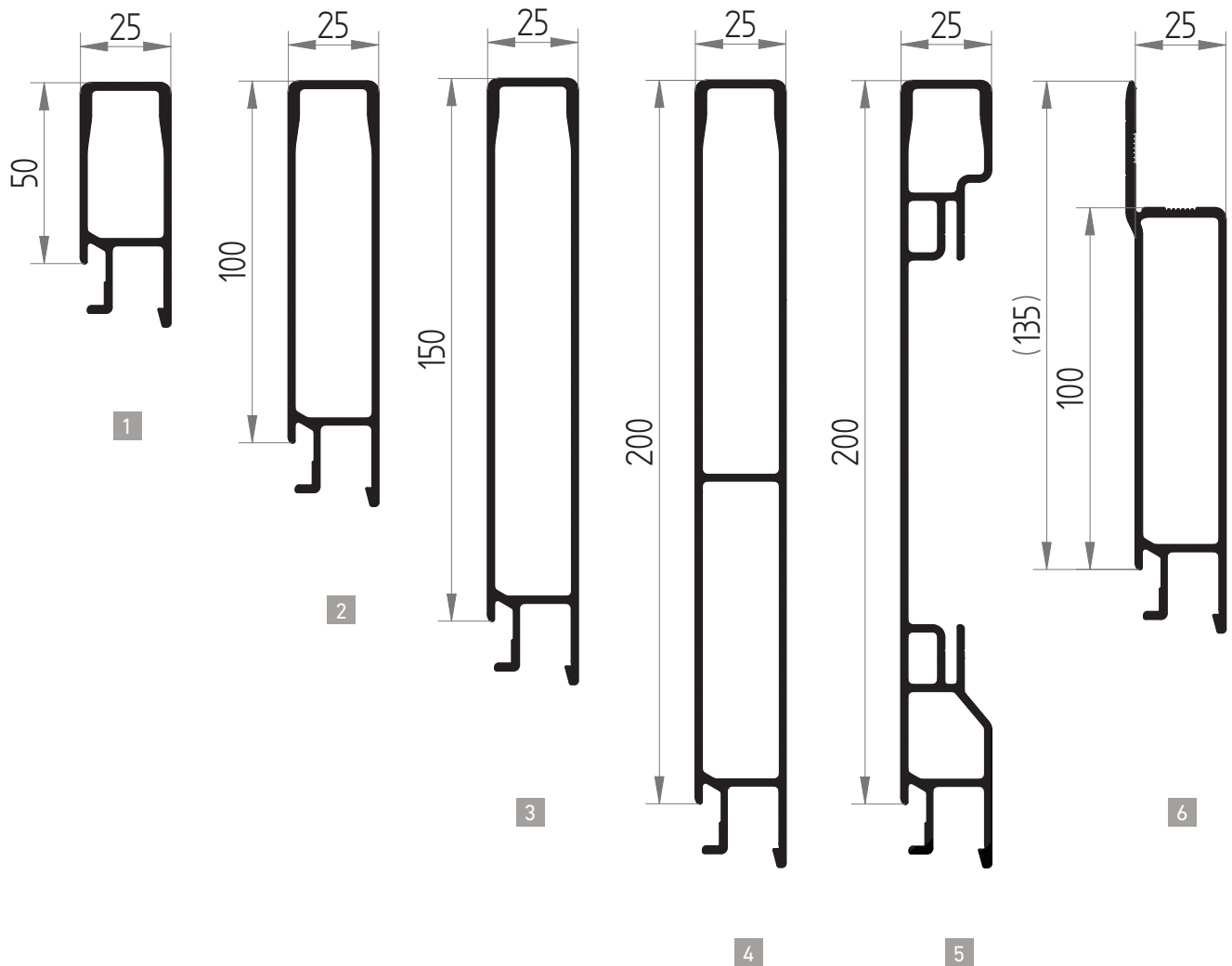

Pos.	Description	Weight	Order no.
1	Upper end profile 50 mm	1.050 kg/m	6.600.001.13
2	Upper end profile 100 mm	1.548 kg/m	6.600.001.14
3	Upper end profile 150 mm	2.046 kg/m	6.600.001.15
4	Upper end profile 200 mm	2.654 kg/m	6.600.001.16
5	Upper end profile 200 mm for lashing rail	2.519 kg/m	6.600.001.40
6	Adapter profile 100 mm for sandwich bulkhead	1.777 kg/m	6.600.001.36

*Subject to change | Date: July 2016

HESTAL SNAP 25 – MIDDLE PROFILES

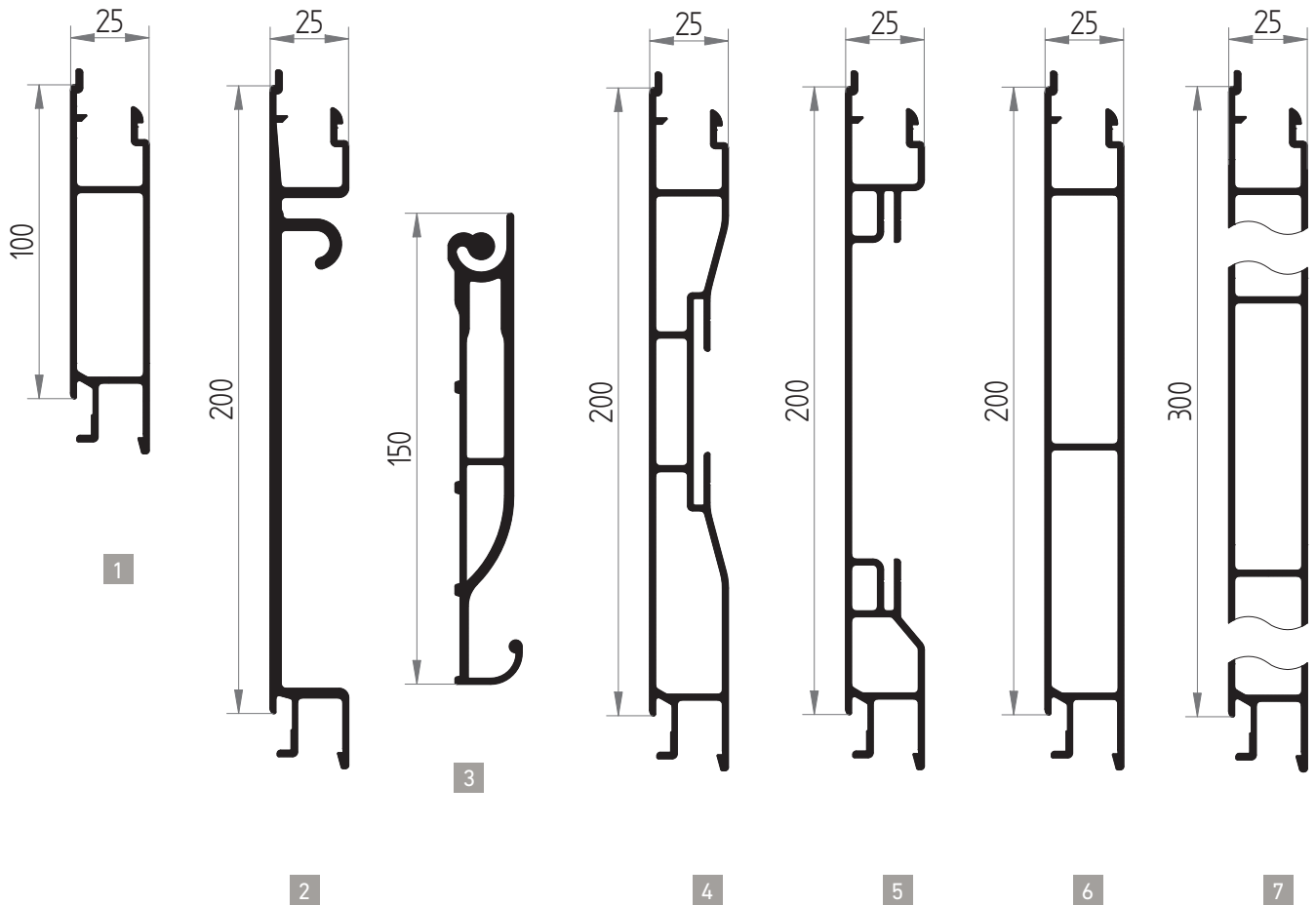

Pos.	Description	Weight	Order no.
1	Middle profile 100 mm	1.525 kg/m	6.600.001.06
2	Middle profile 200 mm, support profile for folding step	2.996 kg/m	6.600.001.11
3	Folding step	2.570 kg/m	6.600.001.12
4	Middle profile 200 mm, for Airline flange rail	2.878 kg/m	6.600.001.38
5	Middle profile 200 mm, for lashing rail	2.377 kg/m	6.600.001.39
6	Middle profile 200 mm	2.625 kg/m	6.600.001.08
7	Middle profile 300 mm	3.743 kg/m	6.600.001.24

*Subject to change | Date: July 2016

HESTAL SNAP 25 – MIDDLE PROFILES FOR CURTAIN CLAMPS

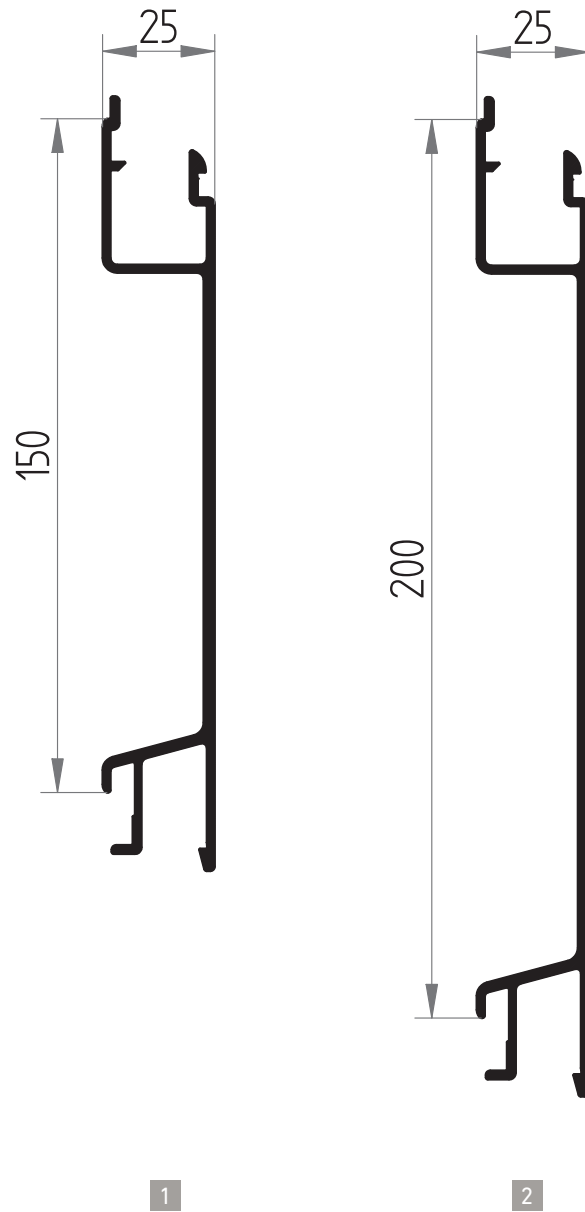

Pos.	Description	Weight	Order no.
1	Middle profile 150 mm, for curtain clamps	1.713 kg/m	6.600.001.09
2	Middle profile 200 mm, for curtain clamps	2.071 kg/m	6.600.001.10

*Subject to change | Date: July 2016

HESTAL SNAP 25 – LOWER END PROFILES

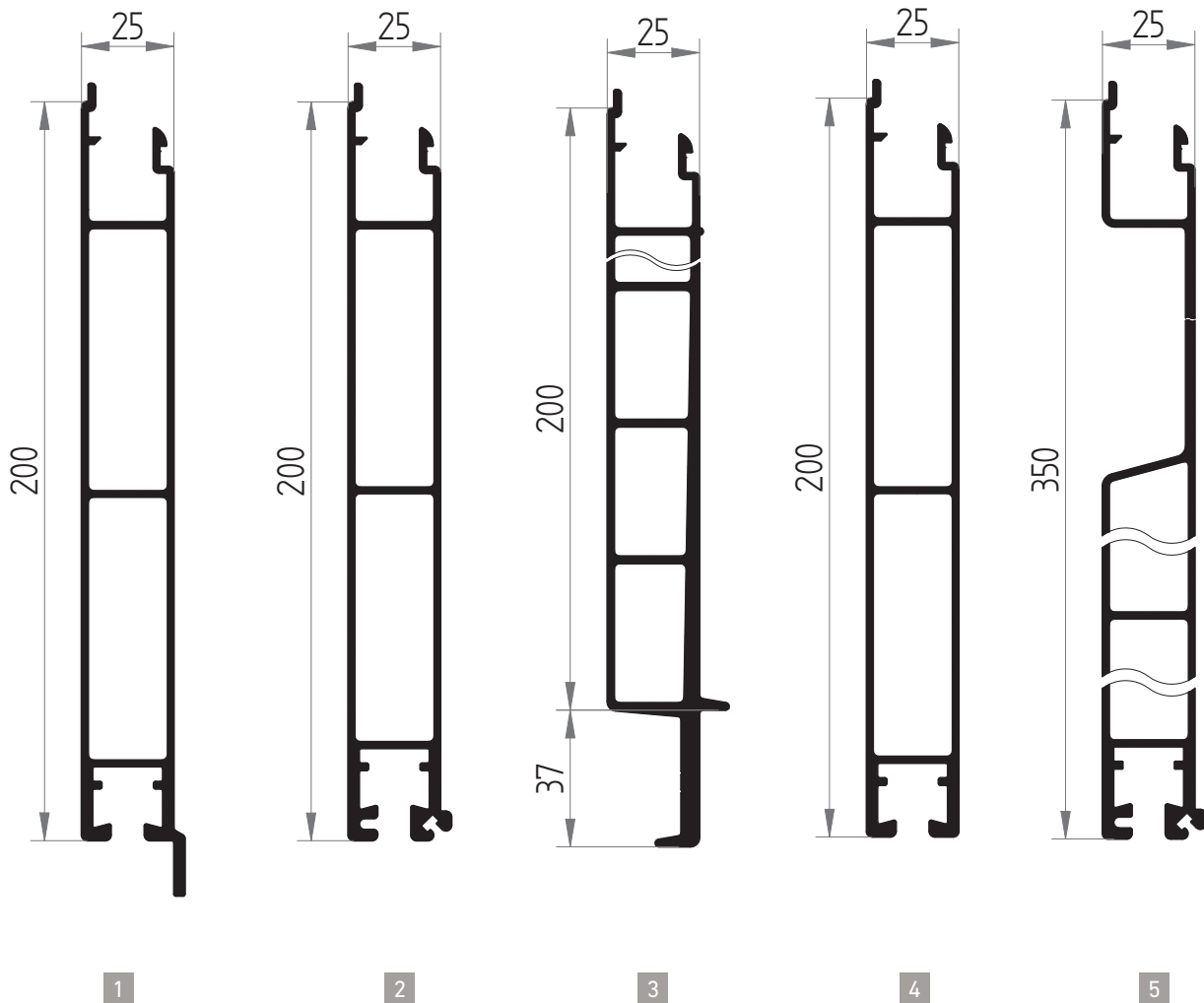

Pos.	Description	Weight	Order no.
1	Lower end profile 200 mm, with rain lug	2.816 kg/m	6.600.001.03
2	Lower end profile 200 mm, for seal	2.791 kg/m	6.600.001.05
3	Lower end profile 200 mm, for additional bulkhead	3.977 kg/m	6.600.001.35
4	Lower end profile 200 mm, smooth bottom	2.544 kg/m	6.600.001.37
5	Lower end profile 350 mm, for curtain clamps for seal	4.058 kg/m	6.600.001.27

*Subject to change | Date: July 2016

HESTAL SNAP 25 – BEZEL PROFILES

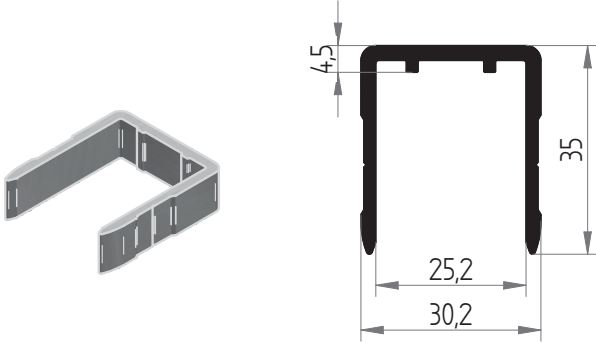
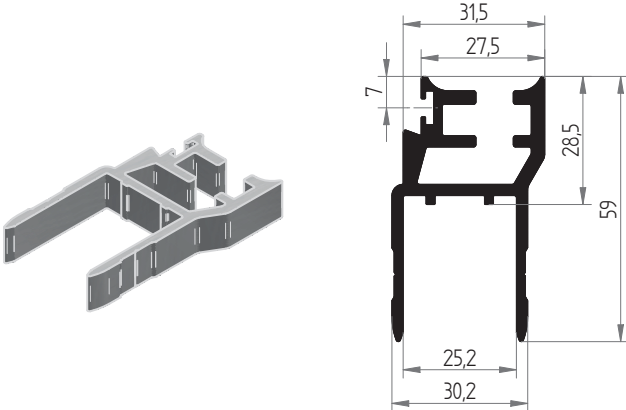
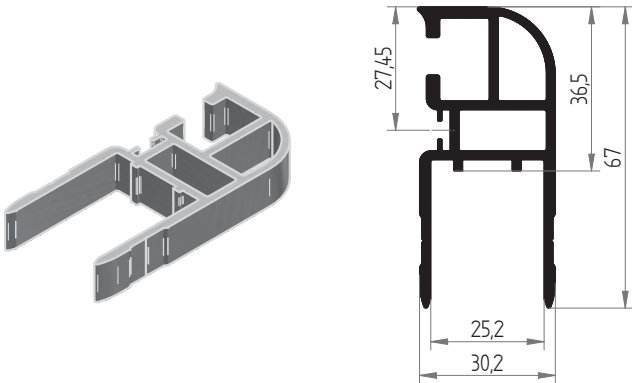
Figure	Weight	Order no.
	0.585 kg/m	6.600.001.17
	1.292 kg/m	6.600.001.18
	1.336 kg/m	6.600.001.19

*Subject to change | Date: July 2016

HESTAL SNAP 25 – BEZEL PROFILES

Figure	Weight	Order no.
	1.219 kg/m	6.600.001.20
	1.177 kg/m	6.600.001.22
	1.127 kg/m	6.600.001.41

*Subject to change | Date: July 2016

HESTAL SNAP 25 – ACCESSORIES

Figure	Description	Weight	Order no.
	<p>Sliding stone M6/M8 for installation of drop-side hinges</p>	0.051 kg/m	6.600.001.28
	<p>Sliding stone M8 for installation of drop-side hinges</p>	0.064 kg	6.600.001.30
	<p>Seal profile for lower end profiles</p>	0.064 kg	6.600.001.31
	<p>Seal profile for side enclosures and rear enclosures 6.600.001.18 + 19</p>	0.030 kg	6.600.001.45

*Subject to change | Date: July 2016

OVERVIEW

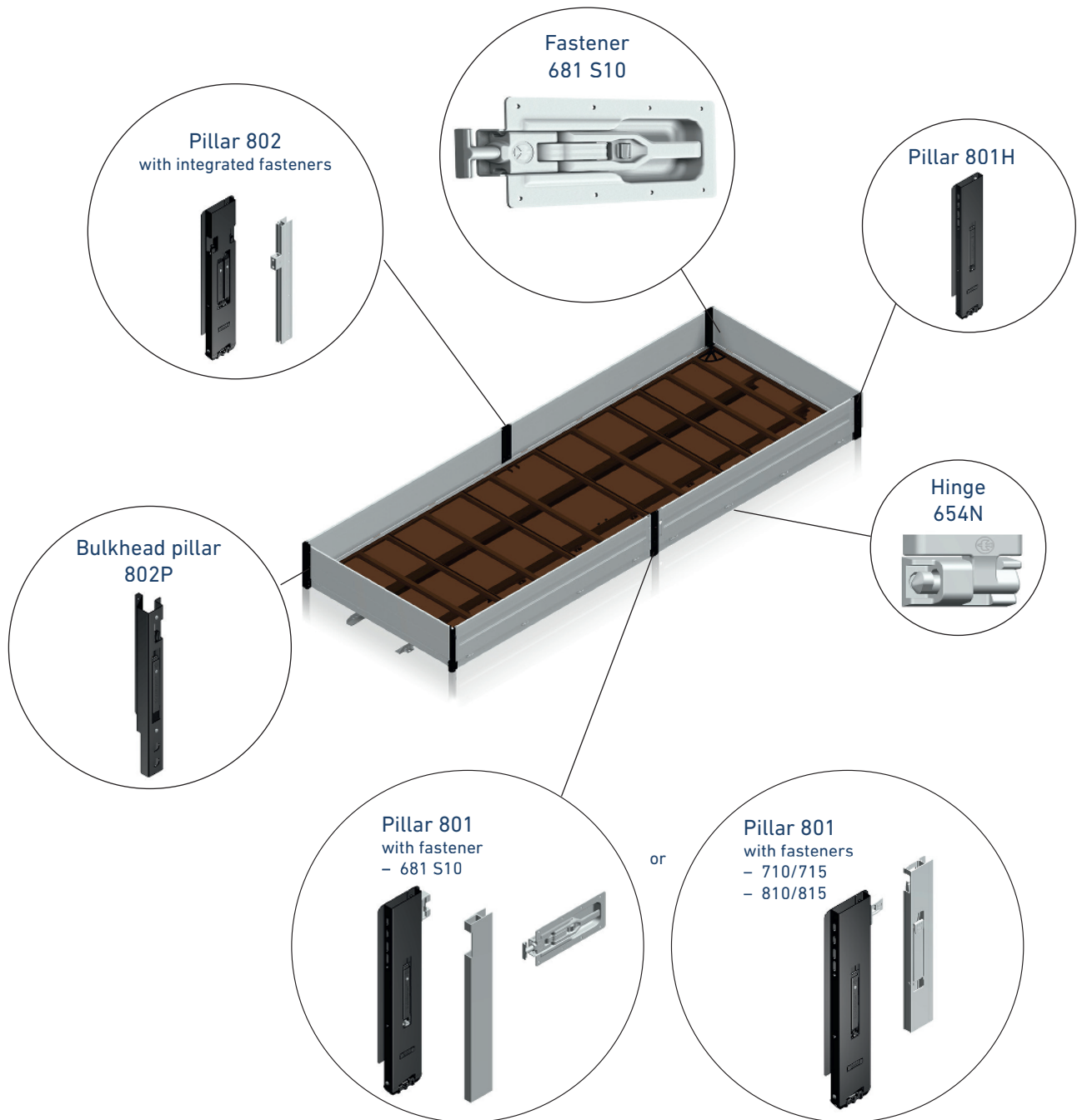

FLATBED SUPERSTRUCTURE

OVERVIEW

Field of application

For commercial vehicles up to 15 t gross vehicle weight

Technology

- Weight saving due to aluminium body
 - Low body weight results in higher payload and reduced fuel consumption
- Ease of installation
 - Quick installation with clamps, bolted variant and preassembly
- Product reliability
 - Dekra-certified up to a payload of 10.7 t Gross vehicle weight in accordance with DIN EN 12642 Code XL Annex A
 - Corrosion protection thanks to KTL coating of the steel parts
- Compatibility
 - Can be combined with tail lift or VarioSave Aluminium load securing system

Versions

- Product variety / high degree of flexibility
- Length up to 7200 mm and maximum overall width up to 2550 mm
- Floor recess (18 mm, 21 mm, 24 mm, 27 mm)
- Drop-side height (400 mm, 500 mm, 600 mm, 800 mm, 1000 mm)
- Bulkhead height up to max. 3160 mm
- Number of lashing points in accordance with DIN EN 12640
- Variable number of cross-members
- Pillar variants (801 and 802)
- Fastener variants (681 S10 and 710)
- Hinge variants (654N)
- Crane superstructures possible

OVERVIEW



CURTAINSIDER SUPERSTRUCTURE

OVERVIEW

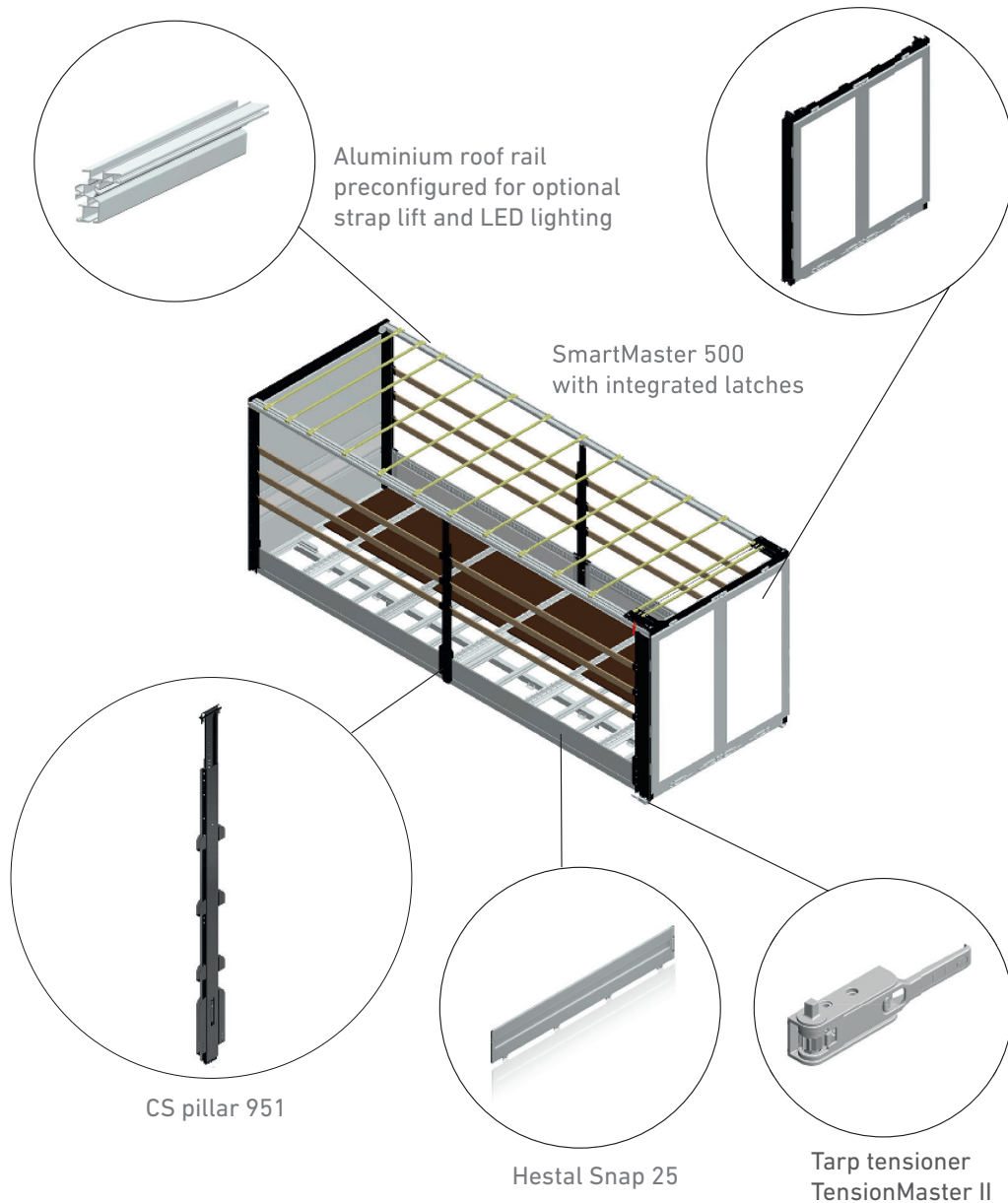

The HESTAL curtainsider superstructure is suitable for light to medium vehicle classes. It offers a weight-optimised solution in conjunction with the HestalBase aluminium substructure.

The aluminium VarioSAVE system can be integrated easily into the substructure and offers the possibility of positive-fit cargo securing. Therefore the loading process will be shortened which results in time saving.

The superstructure is available with SmartMaster rear doors either in aluminium or sandwich. The tarpaulin frame can be designed either as a fixed tarpaulin roof or as a sliding roof.

The corresponding aluminium roof rail can be equipped optionally with the 502 strap lift system that can be positioned all over the cargo area length. Installation of LED cargo space lighting system is also possible. The LiftMaster 770N roof rail system can be used as a special version and is positioned in an own channel in the corner pillars.

All HESTAL components supplied with the kit e.g. middle pillar 951 and TensionMaster are delivered with the well-known high quality and high standard of safety. The required aluminium tarp tensioning tubes and hook profiles are included in the kit.

CURTAINSIDER SUPERSTRUCTURE

OVERVIEW

The HESTAL Curtainsider kit is suitable for light to medium vehicle classes.

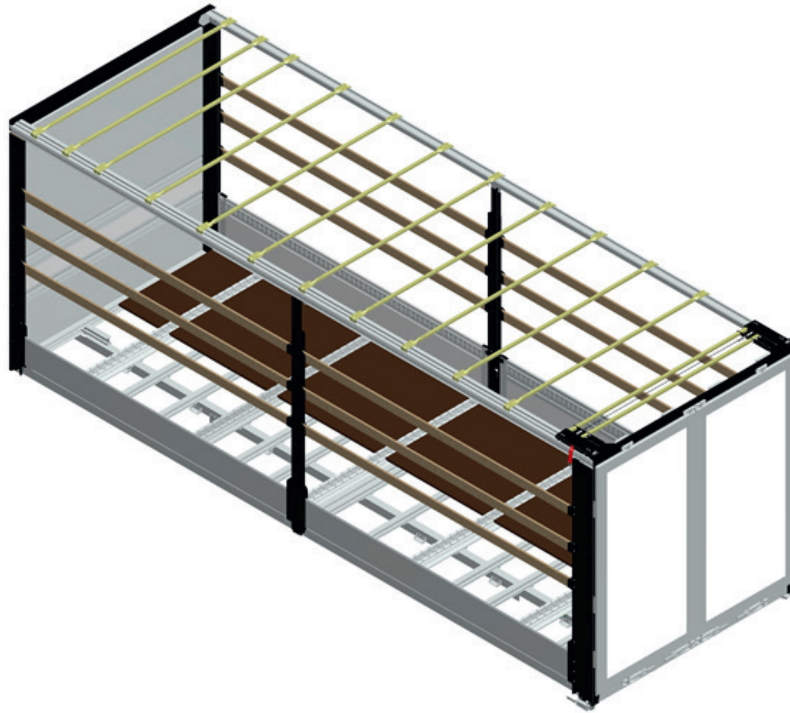

Technology

- High-quality hot-dip galvanising of the front and rear portals and attachments
- Side loading height variable up to 2850 mm (depending on roof rail)
- Customised special solutions possible (e.g. tail lift, rear doors or rear drop-side)
- Rear portal to hold a tail lift with lateral deflectors incl. scuff protection rails
- Drop-sides available with various surface coatings (raw, anodised, powder-coated)
- Aluminium substructure available with different substructure heights (190 mm and 210 mm)
- No cutting or welding necessary
- Various floor thicknesses possible (18/21 mm and 24/27 mm)
- Time saving during installation due to pre-assembled modules
- High corrosion protection: Steel parts KTL coated or hot-dip galvanised
- Customer-friendly delivery due to optimised loading frames

*Subject to change | Date: July 2016

INDIVIDUAL COMPONENTS

CS superstructure



- Structural length up to i.l. 7500 mm
- Structural width up to: 2550 mm
- Special dimensions on request
- Various side loading heights possible
- Payload up to 10.7 tn

HestalBase aluminium substructure



- Low structural weight results in higher payload and reduced fuel consumption
- Quick installation with clamps, bolted version and preassembly
- Corrosion protection due to KTL coating of the steel parts
- Length up to 7500 mm i.l. and max. overall width up to 2550 mm
- Floor thickness (18 mm, 21 mm, 24 mm, 27 mm)
- Number of lashing points in accordance with DIN EN 12640
- Quick installation due to modular system and clamped construction

Hestal Snap aluminium drop-side



- DEKRA certified up to a payload of 10.7 t
- Drop-sides available in heights of 400 mm, 500 mm, 600 mm, 800mm and 1000 mm
- Surface finish in raw, anodised, powder primed and powder coated
- Various lock versions and lashing rails possible

SmartMaster rear door



- High degree of flexibility
- Certified according to DIN EN 12642 XL
- In pure aluminium (500A) or sandwich version (500S)
- Sandwich panel either painted in white or foiled in blue, red or yellow as a 5-years foil
- Other special versions possible
- Advertising foil available ex works

*Subject to change | Date: July 2016

INDIVIDUAL COMPONENTS

CS 951 curtainsider pillars



- High degree of flexibility
- XL certified according to DEKRA requirements profile and in accordance with DIN EN 12642, Annex A
- Roof connection can be adapted individually (in 10 mm grid)
- Pocket position can be adapted individually (in 5 mm grid)
- Slat stowage in 2 different positions
- Pillar bearing identical with SolidMaster connection
- Aluminium plug-in slats incl. end caps 100 x 25 mm

Tarpaulin system



- Branded sliding roof incl. side tarpaulin roller
- Fixed roof version (optionally)
- Lateral PVC seal
- End lift with gas pressure springs (automatic positioning)
- Roof and side tarpaulins on request

VarioSave aluminium cargo securing system



- Quick installation due to modular system and clamped construction
- Time saving during load securing (no lashing)
- Increased safety due to positive-fit locking
- Easy to operate
- No wear parts
- Less cargo damage

*Subject to change | Date: July 2016

INDIVIDUAL COMPONENTS

Roof rail with integrated LED lighting



- Integration of LED light strips for cargo space lighting and increased safety during loading and unloading
- High degree of flexibility due to free positioning of the strap lift system in longitudinal direction

Strap lift 502 cargo securing device



- Easy installation on the roof construction
- For the use of 50 mm wide straps
- Strap lift system infinitely variable in longitudinal direction from one side of the vehicle
- Very narrow top trolleys, enable the individual strap lift systems to be pushed very close together during loading from the side or from above

TensionMaster II tarpaulin tensioner



- Quick and easy bolted mounting
- Available with slotted shaft or squared shaft
- Simple tensioning and untightening of the tarpaulin (single-handed operation)
- Use of high-strength materials

Lashing rings



- Tensile strength 2000 daN
- Number of lashing rings on request

*Subject to change | Date: July 2016

CONFIGURATION TEMPLATES

CURTAINSIDER SUPERSTRUCTURE KIT – TRUCK – Technical questionnaire for customers

Enquiry

Order

Gross vehicle weight

up to 15 t

up to _____ t

Desired body dimensions

Inside body length: _____ mm Overall body length: _____ mm

Inside body width: _____ mm Overall body width: _____ mm

Inside lateral loading height: _____ mm _____ mm

Configuration of kit

Certificate

Code L

Code XL

HestalBase aluminium flatbed body

yes, for further details see additional questionnaire no

Front bulkhead (volume, filling 25 mm aluminium)

with bulkhead support

Bulkhead height: _____ mm installed

raw

anodised
at additional charge

primed
at additional charge

powder-coated, RAL
at additional charge

VarioMaster middle pillars

900/901

902

903

904

905

951

Number _____

Slat stowage
short

Slat stowage
long

Pockets

Number _____

Aluminium slats Number _____ Height _____

Aluminium V slats

Number _____ Height _____

Rear portal

Corner pillars are always hot-dip galvanised!

SmartMaster rear door

yes

no

500A Aluminium

500S Sandwich

raw

anodised
at additional charge

primed
at additional charge

powder-coated, RAL
at additional charge

with advertising

Tarp

Versus

Sesam

Strap Lift 502

Lighting

Camera

Tarp connection

Lifting roof

770N

855N

TensionMaster II tarp tensioner

Squared shaft

Slotted shaft

Tarp tensioning
tubes

Tarp tensioning hooks

Tarpaulins

Roof
tarpaulins

Side
tarpaulins

Drop-sides

Drop-side height: _____ mm

Rear drop-side yes no

Fastener 681 S10

Fastener 710/715

Fastener 810/815

Please contact us by telephone for enquiries and special variants

Date

Agent

(F. Hesterberg)

Client

(please enter in block letters)

Date / Company stamp / Signature

CONFIGURATION TEMPLATES

CURTAINSIDER SUPERSTRUCTURE KIT - TRAILER – Technical questionnaire for customers

Enquiry Order

Gross vehicle weight up to 15 t up to 18 t up to 20 t up to _____ t

Desired body dimensions

Inside body length: _____ mm Overall body length: _____ mm
 Inside body width: _____ mm Overall body width: _____ mm
 Inside lateral loading height: _____ mm

Configuration of kit

Front bulkhead (volume, filling 25 mm aluminium)

Standard with bulkhead support
 Volume

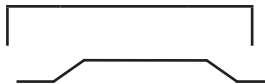

Bulkhead height: _____ mm installed

raw anodised at additional charge primed at additional charge powder-coated, RAL at additional charge

VarioMaster middle pillars

<input type="checkbox"/> 900/901	<input type="checkbox"/> 902	<input type="checkbox"/> 903	<input type="checkbox"/> 904	<input type="checkbox"/> 905	<input type="checkbox"/> 951	Number	_____
<input type="checkbox"/> Slat stowage short	<input type="checkbox"/> Slat stowage long			<input type="checkbox"/> Pockets		Number	_____
<input type="checkbox"/> Aluminium slats	Number	_____	Height	_____	<input type="checkbox"/> Aluminium V slats	Number	_____
						Height	_____

Rear portal

Corner pillars are always hot-dip galvanised!

SmartMaster rear door

yes no

500A Aluminium 500S Sandwich

raw anodised at additional charge primed at additional charge powder-coated, RAL at additional charge with advertising

Tarp Versus Sesam Strap Lift 502 Lighting Camera

Tarp connection

Lifting roof 770N 855N

TensionMaster II tarp tensioner

Squared shaft Slotted shaft
 Tarp tensioning tubes Tarp tensioning hooks

Tarpaulins Roof tarpaulins Side tarpaulins

Drop-sides

Drop-side height: _____ mm Rear drop-side yes no

Fastener 681 S10 Fastener 710/715 Fastener 810/815

Please contact us by telephone for enquiries and special variants

Date _____
 Agent _____
 Client _____
 (F. Hesterberg)

Date / Company stamp / Signature

(please enter in block letters)

CONFIGURATION TEMPLATES

HESTALBASE ALUMINIUM FLATBED KIT – TECHNICAL QUESTIONNAIRE

Enquiry Order

Please note that the HestalBase aluminium flatbed body kit is only suitable for chassis up to 15 t gross vehicle weight

Flatbed trailer Flatbed Box body chassis

Gross vehicle weight up to 7.5 t 7.5 to 15 t

Desired body dimensions

Inside body length: _____ mm Overall body length: _____ mm
 Inside body width: _____ mm Overall body width: _____ mm

Chassis height

190 mm 210 mm Steel 190 mm without auxiliary frame (crane superstructure)

Floor thickness

18 mm 21 mm 24 mm 27 mm

Design of the flatbed body

raw anodised at additional charge primed at additional charge powder-coated, RAL at additional charge

Additional cross-members _____ Qty.
 Number according to accident prevention regulation standard!

Lashing rings _____ Qty.
 with body brackets
 with collision protection profile

VarioSave longitudinal _____ Qty.
 VarioSave transverse _____ Qty.
 VarioSave Sticks _____ Qty.

bare metal or anodised
 Length _____
 Length _____

Drop-side heights

Bulkhead: _____ mm Lashing rail

Rear panel: _____ mm Lashing rail Hasp profile Fixed rear panel

Side wall: _____ mm Lashing rail Hasp profile

Folding step Position: _____

Design of the drop-sides

raw anodised at additional charge primed at additional charge powder-coated, RAL at additional charge

Floor assembly

Please note that the HestalBase aluminium flatbed body kit is always supplied without floor

Front bulkhead pillars, fixed, for tarp frame, ladder frame, etc.
 Middle pillar, folding Roof bow attachment for roof
 Rear corner pillar, folding
 Rear corner pillar fixed, for tail lift, with reinforced auxiliary frame

Fastener system 720 is used in kits without pillars (max. drop-side height 500 mm)

Please contact us by telephone for enquiries and special variants

Date _____
 Agent _____
 Client _____

Date / Company stamp / Signature

ORDER NO.	PAGE	ORDER NO.	PAGE
6.510.354.99	209	6.600.001.36	212
6.510.363.00	209	6.600.001.37	215
6.510.409.99	208	6.600.001.38	213
6.510.410.99	208	6.600.001.39	213
6.510.418.99	208	6.600.001.40	212
6.510.419.99	208	6.600.001.41	217
6.510.430.99	209	6.600.001.45	218
6.510.469.98	210	6.620.001.00	196
6.510.469.99	210	6.620.001.00	201
6.510.470.99	210	6.620.001.01	196
6.510.481.98	210	6.620.001.01	201
6.510.481.99	210	6.620.001.02	196
6.510.533.99	210	6.620.001.02	201
6.510.595.97	210	6.620.001.03	196
6.510.595.98	210	6.620.001.03	201
6.510.598.97	210	6.620.001.05	205
6.510.598.99	210	6.620.001.06	205
6.511.355.99	209	6.620.001.09	205
6.511.356.99	209	6.620.001.10	205
6.600.001.03	215	6.620.001.22	206
6.600.001.05	215	6.620.012.00	204
6.600.001.06	213	6.620.014.00	198
6.600.001.08	213	6.620.014.00	203
6.600.001.09	214	6.620.014.10	198
6.600.001.10	214	6.620.014.10	204
6.600.001.11	213	6.620.014.20	197
6.600.001.12	213	6.620.014.20	203
6.600.001.13	212	6.620.014.30	202
6.600.001.14	212	6.620.014.40	197
6.600.001.15	212	6.620.014.40	202
6.600.001.16	212	6.620.014.70	197
6.600.001.17	216	6.620.014.80	197
6.600.001.18	216	6.620.014.80	203
6.600.001.19	216	6.620.014.90	203
6.600.001.20	217	6.630.002.00	204
6.600.001.22	217	6.630.002.10	204
6.600.001.24	213	6.630.002.20	204
6.600.001.27	215	6.630.002.30	204
6.600.001.28	218		
6.600.001.30	218		
6.600.001.31	218		
6.600.001.35	215		

The brands of the BPW Group:



ERMAX®



HESTAL®



HESTAL – THE BRAND OF THE F. HESTERBERG & SÖHN GMBH & CO. KG

Heilenbecker Straße 50-60 • D-58256 Ennepetal • Tel. +49 (0)2333 794-0 • Fax +49 (0)2333 794-162
www.hestal.de • info@hestal.de

HESTAL 
LOCKS YOUR LOAD BEST



Transport solutions

CONTENTS

PRODUCTS WITH SENSORS

Electro-mechanical door lock	236
Integrated LED lighting in the roof rail	240
Roof height monitoring – LiftMaster with sensors	241

LOAD SECURING

VarioSave Aluminium	242
Integrated Strap Lift 501 and 502	244
Tarp-integrated pillars	247

INDEX	249
-------	-----

ELECTRO-MECHANICAL DOOR LOCK

The system

The DoorLock locking system from F. Hesterberg & Söhne GmbH & Co. KG is an additional locking system that is integrated into the HESTAL box van and refrigerated box doors. The basis of the locking unit is the "ELB-Lock" motor from Trans-Safety LOCKS. This motor drives moving locking bolts which engage in the openings provided in the rear portal (top and bottom) (Fig. 1). The whole system is installed in addition to the espagnolette locks mounted on the outside, and is not visible from either the inside or the outside. The opening and closing operations can be controlled remotely via the telematics solution from idem telematics.

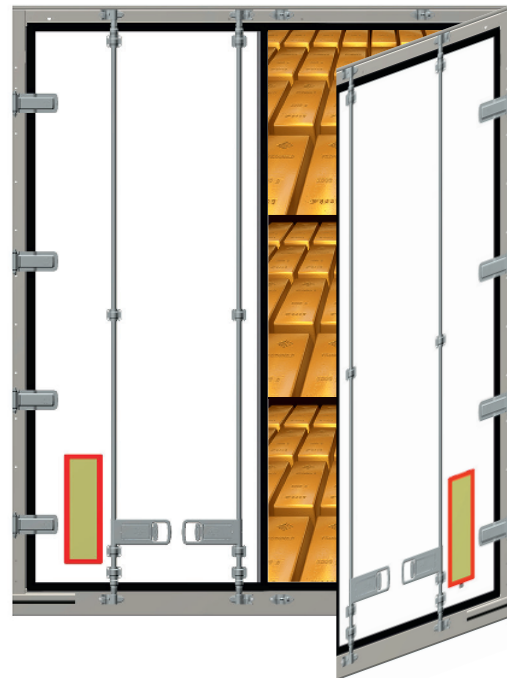

The basic functions

DoorLock locks the doors automatically when they are closed with the espagnolette locks on the outside of the door. Opening is now possible only by entering a user code via the attached keypad (Fig. 2) or via the transmission of a telematics command. At this point the system is generally in a condition in which the driver knows the opening code or user code. If access is to be further limited, e.g. blocking of the user code to prevent the driver from opening the doors, this can also be controlled via the telematics or via the keypad. Subsequent release of the doors for the driver is only possible by transmitting a specific telematics command or by the generation of an individual opening code by the transport company. The opening code must then be sent to the driver, e.g. via telephone or text message, and also be entered via the keypad. The LEDs in the keypad indicate the momentary system state.

Your benefits

- Overview of all door activities
- Protection against theft, burglary and exchange of goods
- Supply of ready-to-install, individually manufactured refrigerated box doors, equipment kit for dry box doors in preparation
- Function with and without telematics link possible
- Suitable for certification of TAPA TSR-1 and GDP (Good Distribution Practice for Pharmaceuticals Transport) and Food Defence (standard for food safety)

*Subject to change | Date: July 2016

ELECTRO-MECHANICAL DOOR LOCK

The refrigerated box door

The Hesterberg refrigerated box doors are flush-fitting doors designed for installation on smooth, plane rear frames.

The sandwich panels of the refrigerated box door have a thickness of 85 mm. They are filled with foam and have a rubber seal on all sides. The inside of the sandwich panel and the outside of the sandwich panel are equipped with an aluminium top layer which standard painting is RAL 9016 white. More top coatings and colours on request. Our corrosion-resistant, high-gloss HESTAL espagnolette locks 890.27 and the hinges of the 895.10 Series are mounted on the outside of the refrigerated box door. The panels have a heat transition coefficient of $<0,4W/m^2k$. The overall heat transition coefficient of the trailer is only insignificantly impacted by the recesses in the door for the installation of the locking unit. A further reason for deciding in favour of the HESTAL refrigerated box door is its Code XL certification in accordance with DIN EN 12642, Annex A.

The dry box door

The HESTAL dry box door also contains a locking unit that is not visible from the outside. As with the refrigerated box door, this door is also designed as a flush-fitting door for plane rear portal frames. The door thickness is 60 mm. The panels are also filled with foam and have a rubber seal on all sides. Their heat transition coefficient is $0.4 W/m^2k$. The hinges and lock fittings and the demands on strength correspond to those of the refrigerated box doors.

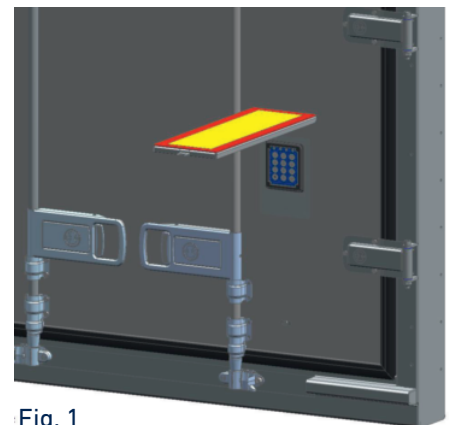

Fig. 1

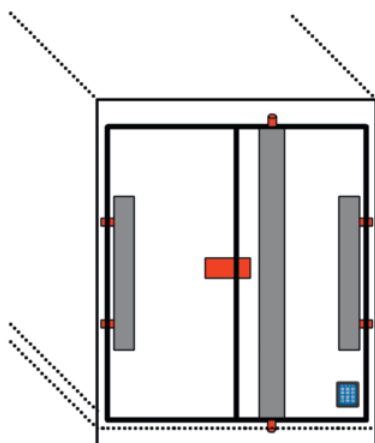

Fig. 2

The locking unit

All mechanical components of the drive installed in the rear door are made of stainless steel (HACCP-compliant). The doors are locked by means of six locking bolts which engage in the rear portal frame (see Fig. 1). The locking unit can be operated both via a concealed keypad installed in the door and via a telematics link in combination with an online telematics portal. An emergency opening tool is available as an option in order to be able to open the doors in the event of an interruption in the power supply.

ELECTRO-MECHANICAL DOOR LOCK



Technical information on the locking motor

- Variable bolt stroke
- Compressive / tensile force 1200 N
- Bolt diameter 25 mm
- Shear force approx. 4000 kg
- Operating voltage 12 or 24 V, connection to the battery of the tractor unit or the battery of the cooling unit; alternatively, operation with a separate rechargeable battery is also possible
- Working range of the electronics from -35 °C to $+70\text{ °C}$
- Protection class IP 66 dynamic



Technical information on the keypad unit ICM

- Programmable interface for telematics, i.a. RS232
- Real-time clock with event memory
- Low standby current consumption $<15\text{ mA}$
- Working range of the electronics from -35 °C to $+70\text{ °C}$
- Protection class IP 65



The Telematik T – Control from idem telematics

- Two-way communication between lock and telematics system
- Recording of the movement profile, the EBS and temperature data possible
- Tracking and tracing function and geofencing function available
- Can be used as a certified temperature plotter (depending on model)
- Data transmission via GPRS
- Position determination via NAVSTAR / GLONASS (satellite systems)
- All telematics applications in combination with the idem portal

ELECTRO-MECHANICAL DOOR LOCK

The retrofit system

The DoorLock locking system is also available as a retrofit solution for rear doors of different manufacturers. In this variant a frame of approx. 65 mm thickness is fitted to the inside of the door, so that on the one hand no system integration into the door is necessary, and on the other hand doors above a material thickness of ≥ 30 mm can also be retrofitted. There is therefore no need to buy new doors. For installation we recommend that the door is laid flat. All functions are identical with those of the integrated systems. The retrofit solution is delivered as a ready assembled unit and merely has to be installed on the inside of the door (Fig. 3).

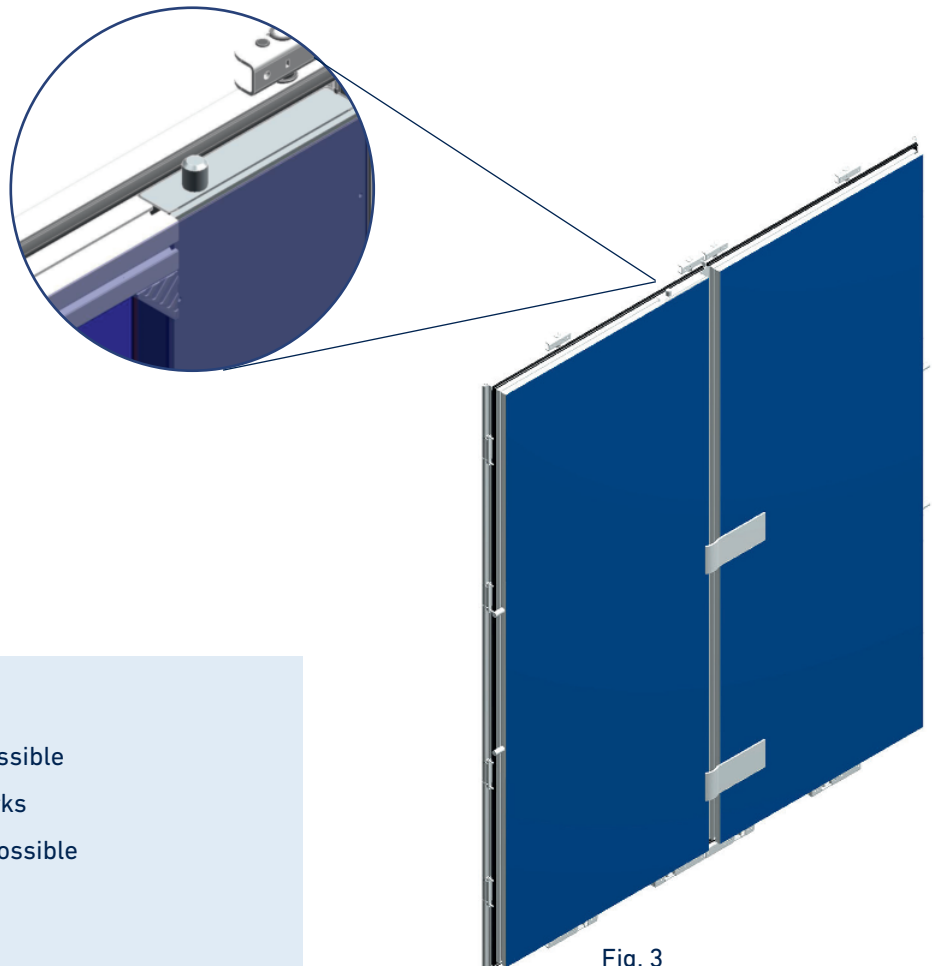

Fig. 3

Your benefits

- Retrofitting on existing doors possible
- Prefabrication of a frame ex works
- Installation on customer's site possible
- Short installation times

INTEGRATED LED LIGHTING IN THE ROOF RAIL

Our integrated LED lighting system offers the optimum solution when the local conditions cannot sufficiently illuminate the cargo area.

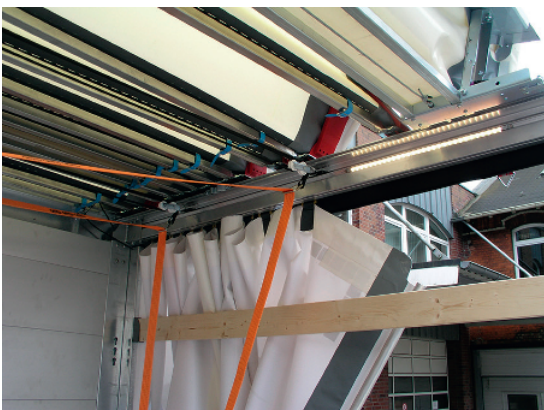

Your benefits

- LED strips of different lengths
- Positioning according to customer demands
- Exit side of the cables and cable lengths individually variable
- Operating current < 500 mA per strip
- Power consumption < 5 W per strip
- Attention: For operation with 24 Volt on-board voltage, a voltage transformer from 24 V to 12 V is required

*Subject to change | Date: July 2016

PRODUCTS WITH SENSORS

ROOF HEIGHT MONITORING – LIFTMASTER WITH SENSORS

The problem

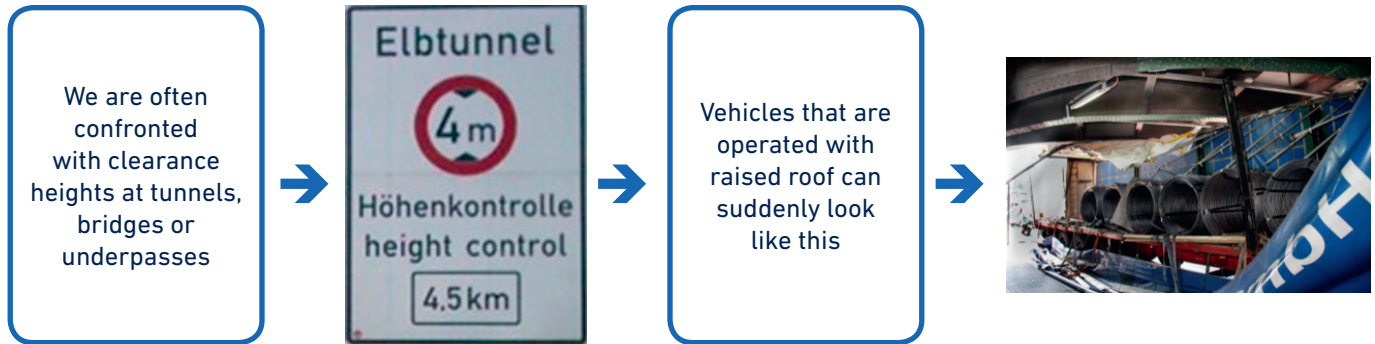

The system

- Sensors for the proven HESTAL LiftMaster system with sturdy sensor technology
- Simple and quick operation, as no additional work steps are necessary
- Integration into idem telematik possible



Your benefits

- Increased safety
- Avoidance of damage caused by bridges and underpasses
- Transparency for the loading operation
- Fuel saving
- Information in real-time for driver and shipping company

*Subject to change | Date: July 2016

VARIOSAVE ALUMINIUM

In conjunction with our aluminium HESTAL BASE flatbed trailer kit, the VarioSAVE system is the positive-fit cargo securing for piece goods and long material in the field of steel and long load transports.

VarioSAVE can be positioned variably and used in longitudinal and transverse direction within the cargo area. Various methods of securing e.g. mobile bulkhead versions and variable lashing possibilities of the VarioSAVE sticks allow individual loading. This depends on the goods being transported.

The aluminium VarioSAVE system can also be used as a lashing point (Fig. 1). This enables the load securing system to be optimised according to the goods being transported. As a result the loading time will be shortened significantly.

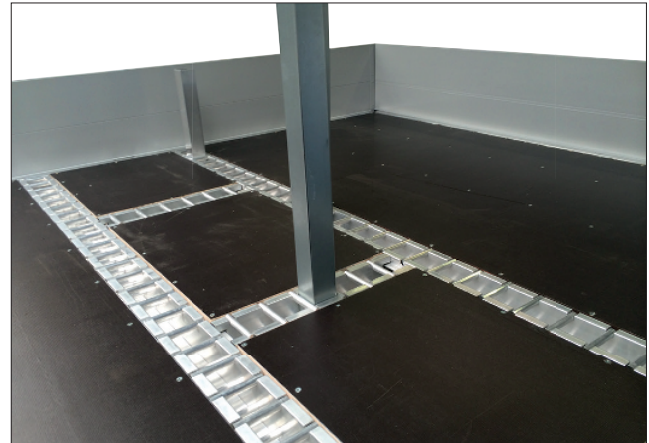

VarioSAVE[®]
Die Ladungssicherung

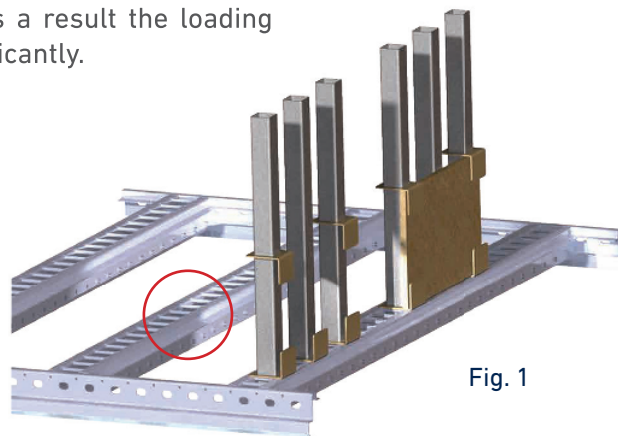

Fig. 1

Users say: "...never again without..."

"We save approx. 30 minutes loading time per vehicle during loading of our delivery vehicles on the eve, we can load with positive-fit locking in several levels and randomly need additional lashing aids...", says plant manager Mr Heimann at G. Elsinghorst Stahl und Technik GmbH in Bocholt who, with 7 vehicles, was one of the first VarioSAVE customers in Germany.

"VarioSAVE can be used very efficiently for mixed loads in regional delivery transports. 10 minutes load securing time can be easily saved at each place of unloading on the customer's premises. With four to six unloading points a day, that means up to 5 hours load securing time saved per week and vehicle."

Background: G. Elsinghorst Stahl und Technik GmbH

G. Elsinghorst is a strong partner for industry, trade and the building sector. On a total area of 43,100 m² for retail market, stores and offices, Elsinghorst with its stock of 12,000 tonnes of sectional steel, bar steel, plates, tubes, stainless steel and NF metals ensures an optimum supply to the steel trade and structural steel industry in North-Rhine Westphalia and the Netherlands at any time.

The complete article can be read at www.variosave.de.

*Subject to change | Date: July 2016

LOAD SECURING

VARIOSAVE ALUMINIUM

Technology

- High-strength aluminium alloy
- Max. load on one cross-member in longitudinal direction: 1500 daN
- Max. load on one cross-member in transverse direction: 1000 daN
- Sticks available in 600 mm and 1200 mm height
- Floor thickness 27 mm
- Bolted version
- Round bolts as lashing point in accordance with DIN EN 12640 up to 1500 daN loading capacity



VarioSAVE Aluminium

Your benefits

- Time saving during cargo securing (due to elimination of lashing)
- Time saving during loading and unloading
- Easy to operate
- Significant reduction of cargo damages
- Maximum flexibility for cargo securing
- Increased transport safety due to positive-fit locking
- Considerable reduction of damages in transit



Advantages

- Weight saving:
 - Up to 40% lighter compared with the steel version
 - Hence lower fuel consumption and
 - Increased payload
- Ease of installation:
 - Quick installation due to modular system and clamped construction
- Product reliability:
 - TÜV certification

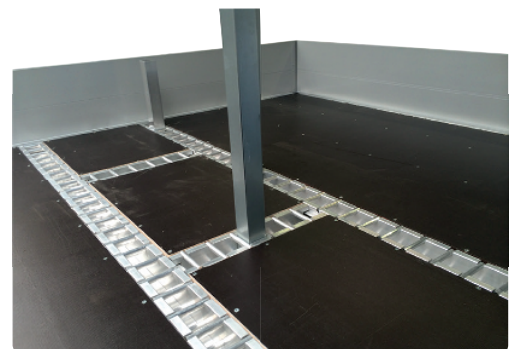

*Subject to change | Date: July 2016

STRAP LIFT SYSTEM 501 – LOAD SECURING DEVICE

Field of application

- The strap lift system is a special load securing device with which eliminates the painful throwing of the lashing straps over the loaded goods
- Wide range of applications in the commercial vehicle sector
- Easy positioning of the lashing straps for load securing
- Quick, effective loading operation
- The operator secures the load without having to climb onto the cargo area

Technology

- Easy installation on the roof construction
- For the use of 50 mm wide tensioner belts

Versions

Hot-dip galvanised to FHS-TL 9.01

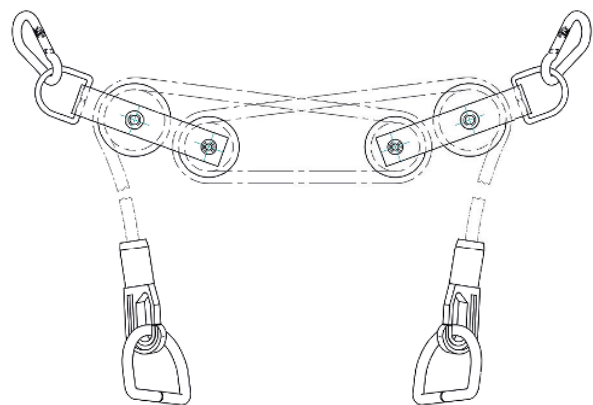

Type	Description	Weight	Order no.
501	Strap Lift set 6 pcs. for sliding roof frame	6.0 kg	1.000.303.00
501	Strap Lift set 6 pcs. for Hamburg roof	6.0 kg	1.000.304.00
501	Strap Lift set 12 pcs. for sliding roof frame	12.0 kg	1.000.305.00
501	Strap Lift set 12 pcs. for Hamburg roof	12.0 kg	1.000.306.00

*Subject to change | Date: July 2016

STRAP LIFT SYSTEM 502 – LOAD SECURING DEVICE

Field of application

The strap lift system is a special load securing device with which throwing of the lashing straps over the loaded goods is eliminated.

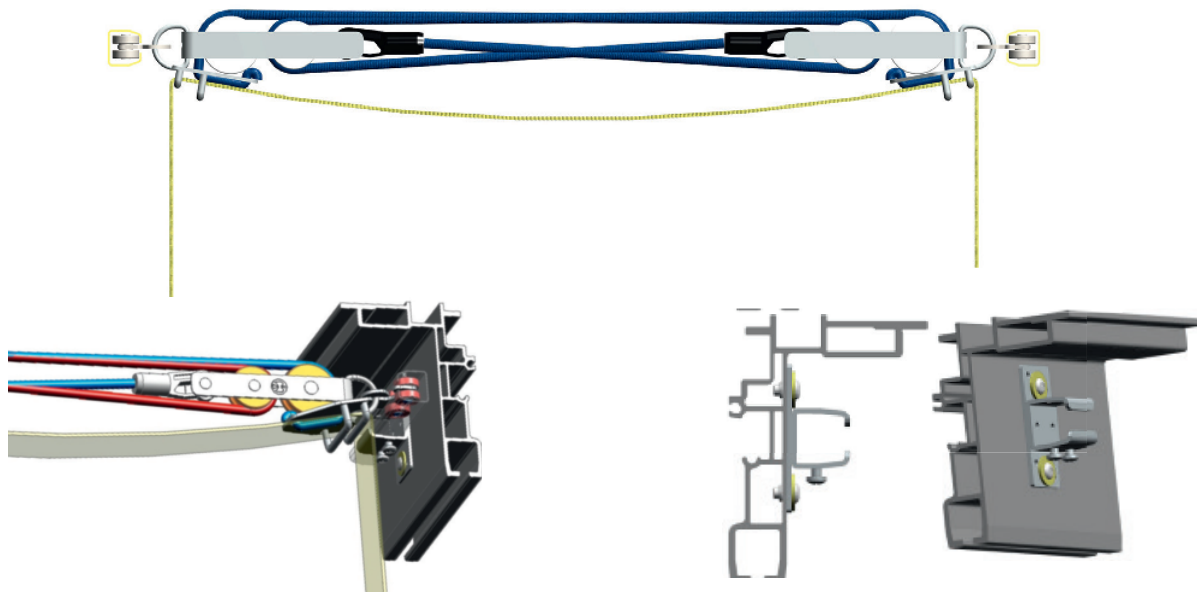

Technology

- Easy installation on the roof construction
- For the use of 50 mm wide tensioner belts
- Riveting of the rail system to the roof rail with corresponding brackets
- Top trolley prevented from slipping out by stoppers
- Strap lift system steplessly adjustable in longitudinal direction from one side of the vehicle
- Very narrow top trolley, allowing the individual strap lift systems to be pushed very close together during loading from above

Components of strap lift system 502

- 2 expander ropes with strap holder and securing hook
- 2 guide pulley sets
- 2 top trolleys with ball bearings

Components of rail system 502

- 6 m rail
- Rail holder
- Connectors
- Stoppers

Type	Description	Weight	Order no.
502	Strap lift system	1,1 kg	1.000.310.00

*Subject to change | Date: July 2016

STRAP LIFT SYSTEM 502 – LOAD SECURING DEVICE

Advantages/benefits

- Time saving of up to 55% achieved through:
 - No need to climb onto the cargo area
 - Positioning of the straps from just one side of the trailer
 - Optimum positioning of the straps thanks to stepless securing positions
 - Easy operation thanks to guided top trolleys
- Less loss of capacity thanks to pulling the strap up to just below the roof of the trailer, depending on the position of the top trolley rails
- Safety improvement due to:
 - Easy and secure strapping of the cargo
 - Better secured cargo reduces risks of accidents

Type	Description	Weight	Order no.
502	Straplift	1,10 kg	1.000.310.00
502	Rail 6 m		1.000.310.20
502	Railholder with 1 fastening tab	0,16 kg	1.000.310.16
502	Railholder with 2 fastening tabs	0,19 kg	1.000.310.17
502	Connector	0,32 kg	1.000.310.18
502	Stopper	0,05 kg	1.000.310.19
502	Edge protection	0,04 kg	1.000.310.28



*Subject to change | Date: July 2016

CS PILLAR INTEGRATED INTO TARPAULIN

Field of application

The tarp-integrated pillar is used particularly on distribution vehicles with sliding side tarpaulins.

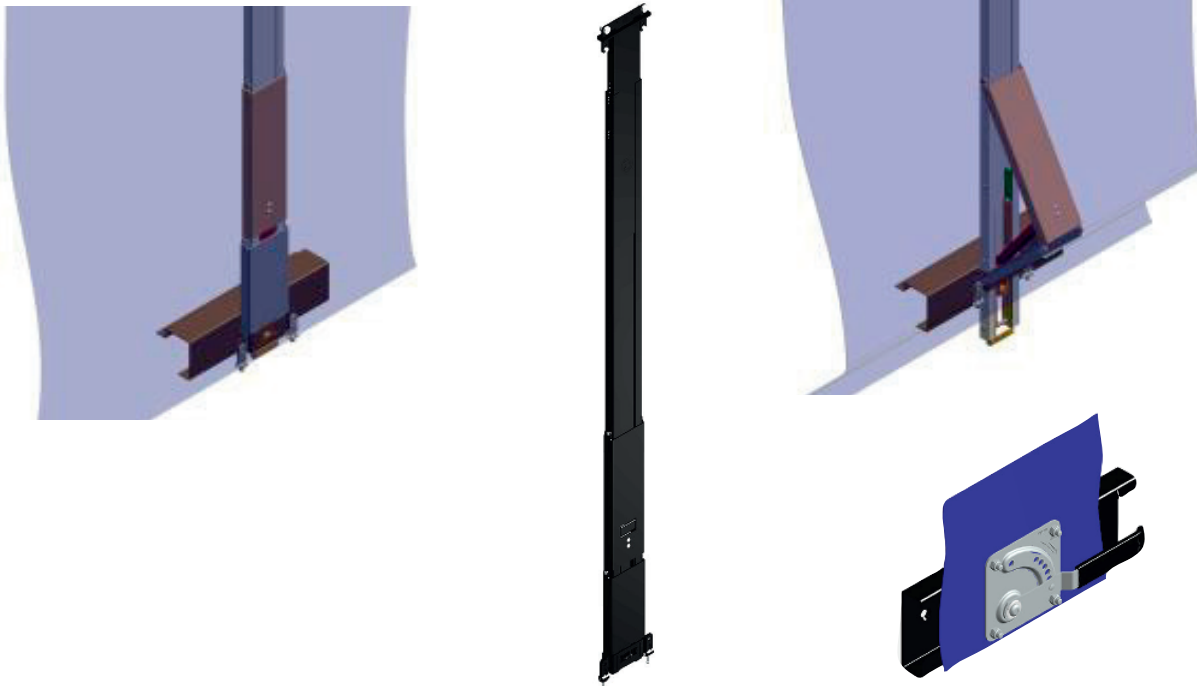

Advantages / benefits of pillar

- The tarp-integrated CS pillar leads to a significant saving in time during loading and unloading thanks to quick opening and closing of the tarps
- High product reliability thanks to Code L and Code XL version (planned) and KTL coating
- High degree of flexibility thanks to adaptation to different roof heights
- The pillar can be locked and unlocked from the outside through the tarp and the tarp is tensioned vertically at the same time
- Time saving thanks to faster opening and closing
- Shortening of walking distances thanks to sliding of tarp and pillar at the same time
- Reduction in the number of additional tarp tensioners

Advantages / benefits of tarp tensioners

- Simple tensioning and securing of the tarps in one step
- Adjustable tarp tension
- Time saving for opening and closing the tarps thanks to quick and easy operation
- System benefits through combination with tarp-integrated pillars

*Subject to change | Date: July 2016

ODER NO.	PAGE
1.000.303.00	244
1.000.304.00	244
1.000.305.00	244
1.000.306.00	244
1.000.310.00	245
1.000.310.00	246
1.000.310.20	246
1.000.310.16	246
1.000.310.17	246
1.000.310.18	246
1.000.310.19	246
1.000.310.28	246

The brands of the BPW Group:



ERMAX®



HESTAL®



HESTAL – THE BRAND OF THE F. HESTERBERG & SÖHNE GMBH & CO. KG

Heilenbecker Straße 50-60 • D-58256 Ennepetal • Tel. +49 (0)2333 794-0 • Fax +49 (0)2333 794-162
www.hestal.de • info@hestal.de

HESTAL 
LOCKS YOUR LOAD BEST